

MODEL : LK-1900

List No : 1190-06

PARTS LIST

Published:09/10/2017

CONTENTS

FRAME & MISCELLANEOUS COVER COMPONENTS	1
MAIN SHAFT & NEEDLE BAR COMPONENTS	5
PRESSER LIFTER COMPONENTS	9
SHUTTLE DRIVER SHAFT COMPONENTS.....	13
WIPER MECHANISM COMPONENTS	17
TENSION RELEASE & THREAD TENSION COMPONENTS.....	19
TENSION RELEASE & THREAD TRIMMER MECHANISM COMPONENTS.....	21
FEED MECHANISM COMPONENTS.....	25
LUBRICATION COMPONENTS	29
SENSOR & EXTENSION CABLE COMPONENTS	31
THREAD STAND COMPONENTS.....	33
CONTROL BOX COMPONENTS	35
OPERATION BOX & PEDAL COMPONENTS.....	39
WIRING DIAGRAM.....	41
ACCESSORIE PART COMPONENTS	43
OPTION COMPONENTS(1).....	47
OPTION COMPONENTS(2)(FOR LK-1900,1901,1902)	51
TABLE COMPONENTS	53
LK-1901S△:WORK CLAMP MECHANISM COMPONENTS.....	55
LK-1901:WORK CLAMP SOLENOID COMPONENTS.....	59
LK-1902S△	61
LK-1902H△	65
LK-1903S△-30△.....	67
LK-1903-301:BUTTON CLAMP COMPL. FOR SMALL-BUTTONS	69
LK-1903-302:LK-1903-303:LK-1903-304.....	73
LK-1903-305:SHANK BUTTON CLAMP MECHANISM COMPONENTS.....	77
LK-1904	81
ACCESSORIES PARTS FOR LK-1900 SUB CLASSES	83
LIST FOR INFORMATION OF CHANGE.....	85
HOW TO MAKE USE OF THIS PARTS LIST	86

FRAME & MISCELLANEOUS COVER COMPONENTS

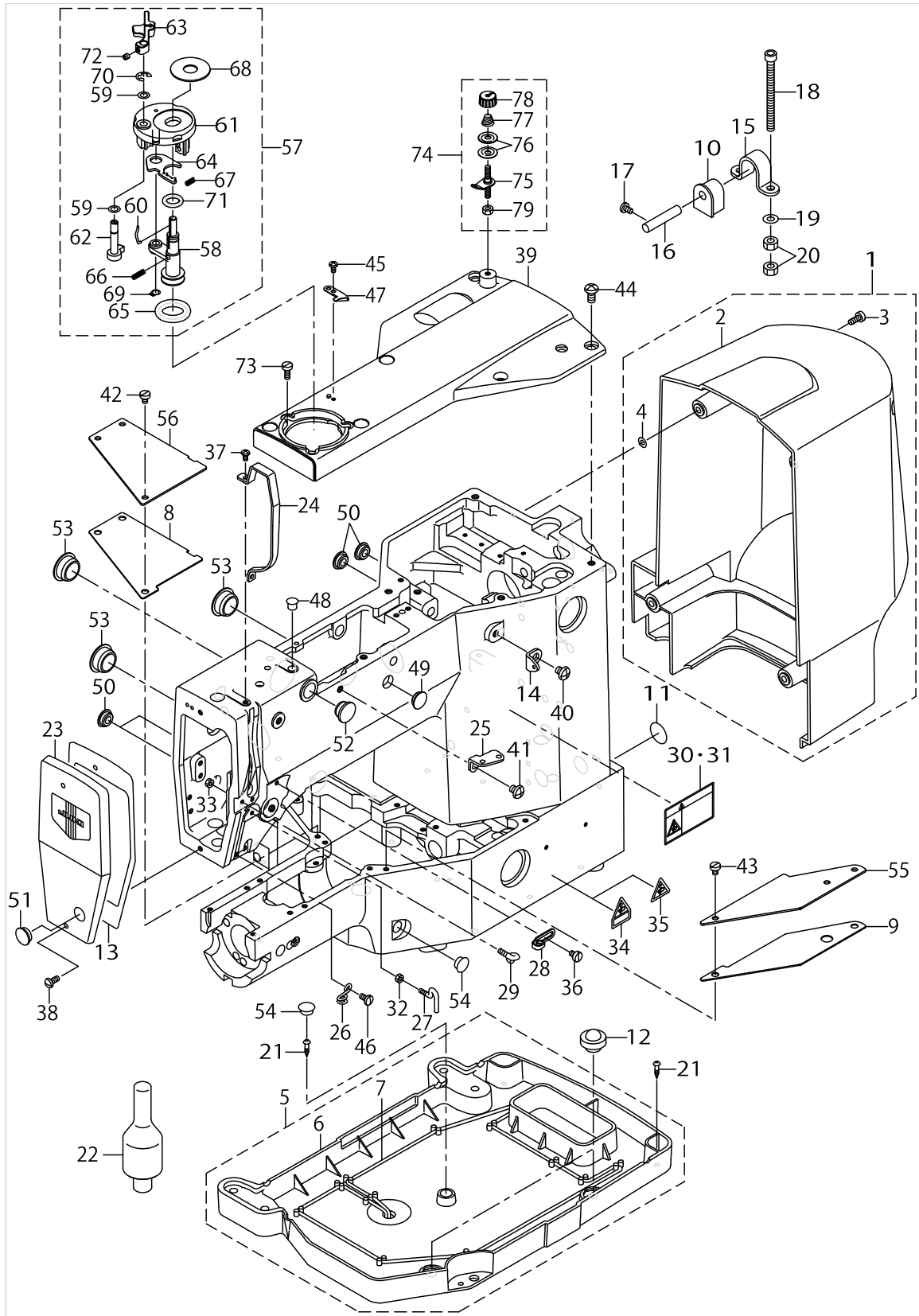

FRAME & MISCELLANEOUS COVER COMPONENTS

No.	Parts No.	Parts name	Remarks	Level	Cons	Qty
1	14100457	MOTOR COVER ASM.				1
2	14100408	MOTOR COVER		*		1
3	SS6111140SP	SCREW 11/64-40 L=11		*		4
4	M8002430000	STOPPER		*		4
5	14100754	OIL PAN ASM.				1
6	14100705	OIL PAN		*		1
7	CQ252200000	OIL WICK		*		1
8	14100903	BED COVER PACKING A				1
9	14101000	BED COVER PACKING B				1
10	B1115210D00	HINGE RUBBER				2
11	10004109	GROUND MARK				1
12	B1116210D00	FRAME SUPPORT RUBBER				2
13	13502307	FACE PACKING				1
14	13786306	THREAD GUIDE NO.1				1
15	B1111210D00	BED HINGE				2
16	B2707761000	HINGE STUD				2
17	SS7110730SP	SCREW 11/64-40 L= 6.5				2
18	SM6067552TP	HEXAGONAL-HOLE BOLT M6 L=75				4
19	WP0651646SC	WASHER				4
20	NM6060001SC	NUT M6				8
21	SK3382001SE	SCREW D=3.8 L=20				4
22	14101208	HEAD SUPPORT BAR				1
23	13816764	FACE COVER ASM.				1
24	26211607	BALANCE COVER				1
25	B1111232000	THREAD GUIDE PLATE				1
26	B1124280000	ARM THREAD GUIDE B				1
27	B1125280000	L-SHAPED THREAD GUIDE A				1
28	11018504	ARM THREAD GUIDE A				1
29	B3114771000	THREAD GUIDE				1
30	CM300200101	SAFETY LABEL, 1(SMALL).	FOR USE IN JAPAN			1
31	CM3002001A1	SAFETY LABEL.,3 (SMALL).	EXCEPT JE & USE IN JAPAN			1
32	NS6090310SP	NUT 9/64-40				1
33	NS6090310SP	NUT 9/64-40				1
34	CM3002000B2	LABEL(25).	FOR USE IN JAPAN			1
35	CM300200002	CAUTION LABEL(25)				1
36	SS6110610TP	SCREW 11/64-40 L=6				1
37	SS4090715SP	SCREW 9/64-40 L=7				2
38	SS4111015SP	SCREW 11/64-40 L=10				2
39	14100309	TOP COVER				1
40	SS4150715SP	SCREW 15/64-28 L=7				1
41	SS4150715SP	SCREW 15/64-28 L=7				1
42	SS6110610TP	SCREW 11/64-40 L=6				3
43	SS6110610TP	SCREW 11/64-40 L=6				2
44	SS4151215SP	SCREW 15/64-28 L=12				6
45	SS4090715SP	SCREW 9/64-40 L=7				1
46	SS7110840SP	SCREW 11/64-40 L=7.8				1
47	10502300	THREAD CUTTER				1

FRAME & MISCELLANEOUS COVER COMPONENTS

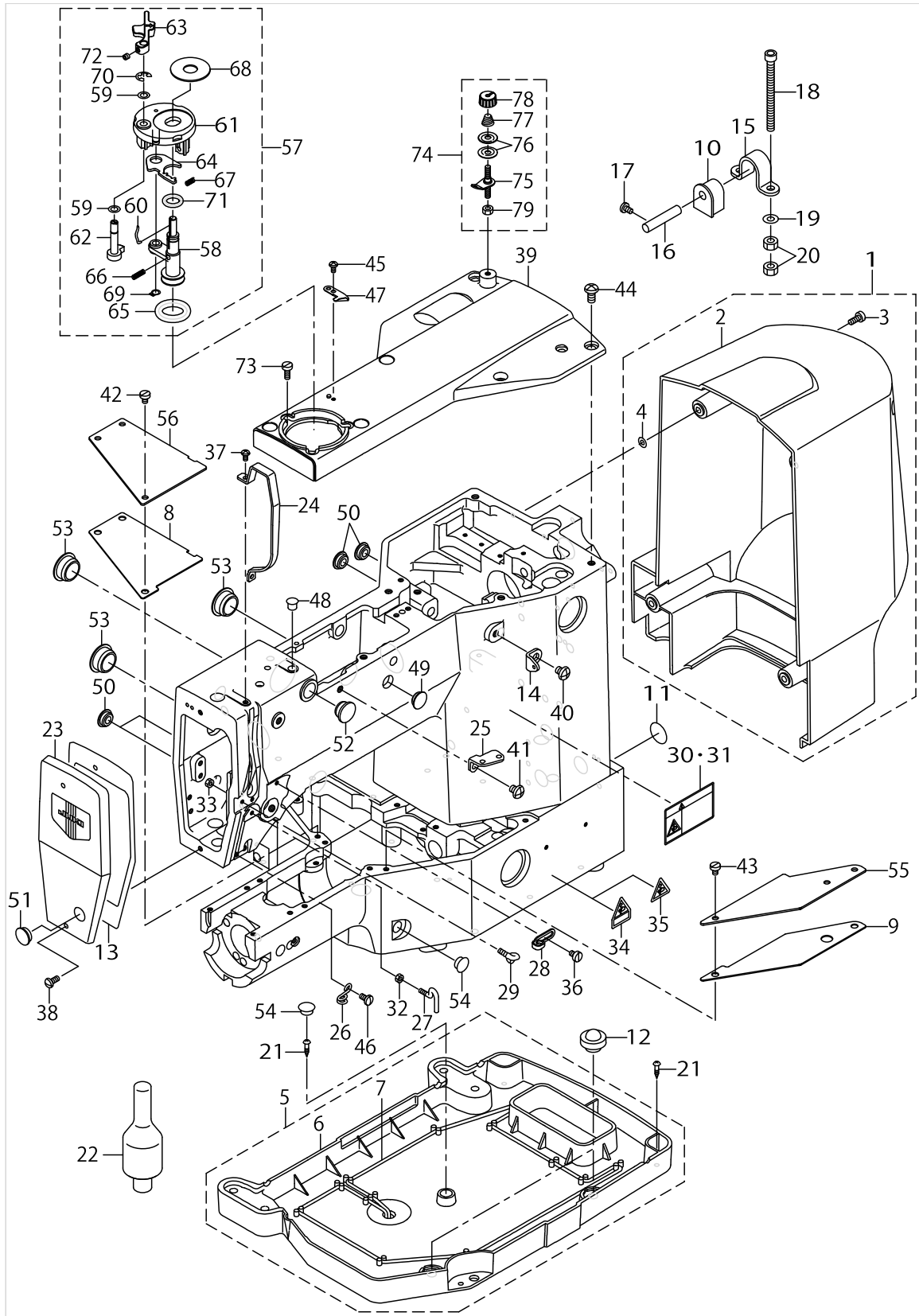

FRAME & MISCELLANEOUS COVER COMPONENTS

No.	Parts No.	Parts name	Remarks	Level	Cons	Qty
48	TA0750704R0	RUBBER PLUG				1
49	TA1250406R0	RUBBER PLUG D=12.5 L=4				1
50	TA1250406R0	RUBBER PLUG D=12.5 L=4				4
51	TA1250406R0	RUBBER PLUG D=12.5 L=4				1
52	TA1470704R0	RUBBER PLUG				1
53	TA2100904R0	RUBBER PLUG				3
54	TA1050504R0	RUBBER PLUG				2
55	14100606	BED COVER B				1
56	14100507	BED COVER A				1
57	14113666	BOBBIN WINDER ASM.				1
58	14113658	BOBBIN WINDER SHAFT COMPL.		*		1
59	13507504	WASHER		*		1
60	B3212761000	LATCH SPRING		*		1
61	22537658	BOBBIN FITTING BASIS COMPL.		*		1
62	22538151	BOBBIN CAM SHAFT COMPL.		*		1
63	22538300	BOBBIN LEVER		*		1
64	22538409	ADJUSTING PLATE		*		1
65	A321600100A	RUBBER RING		*		1
66	B1148555000	SPRING		*		1
67	B152989000CA	PRESSUR FOOT SPRING		*		1
68	B3205210000	CUSHION		*		1
69	RC0560711KP	RETAINING RING		*		1
70	RE0500000K0	E-RING		*		1
71	RO092270200	RUBBER RING		*		1
72	SS8110422TP	SCREW 11/64-40 L=4		*		1
73	SS61111140SP	SCREW 11/64-40 L=11				3
74	14113468	BOBBIN THREAD TENSION ASM.				1
75	14113450	BOBBIN THREAD TENSION ROD ASM.		*		1
76	B3126012000	THREAD TENSION DISK		*		2
77	D7133555B00	CONNECTING ROD SPRING		*		1
78	11072402	THREAD TENSION NUT		*		1
79	NS6110310SP	NUT 11/64-40		*		1

MAIM SHAFT & NEEDLE BAR COMPONENTS

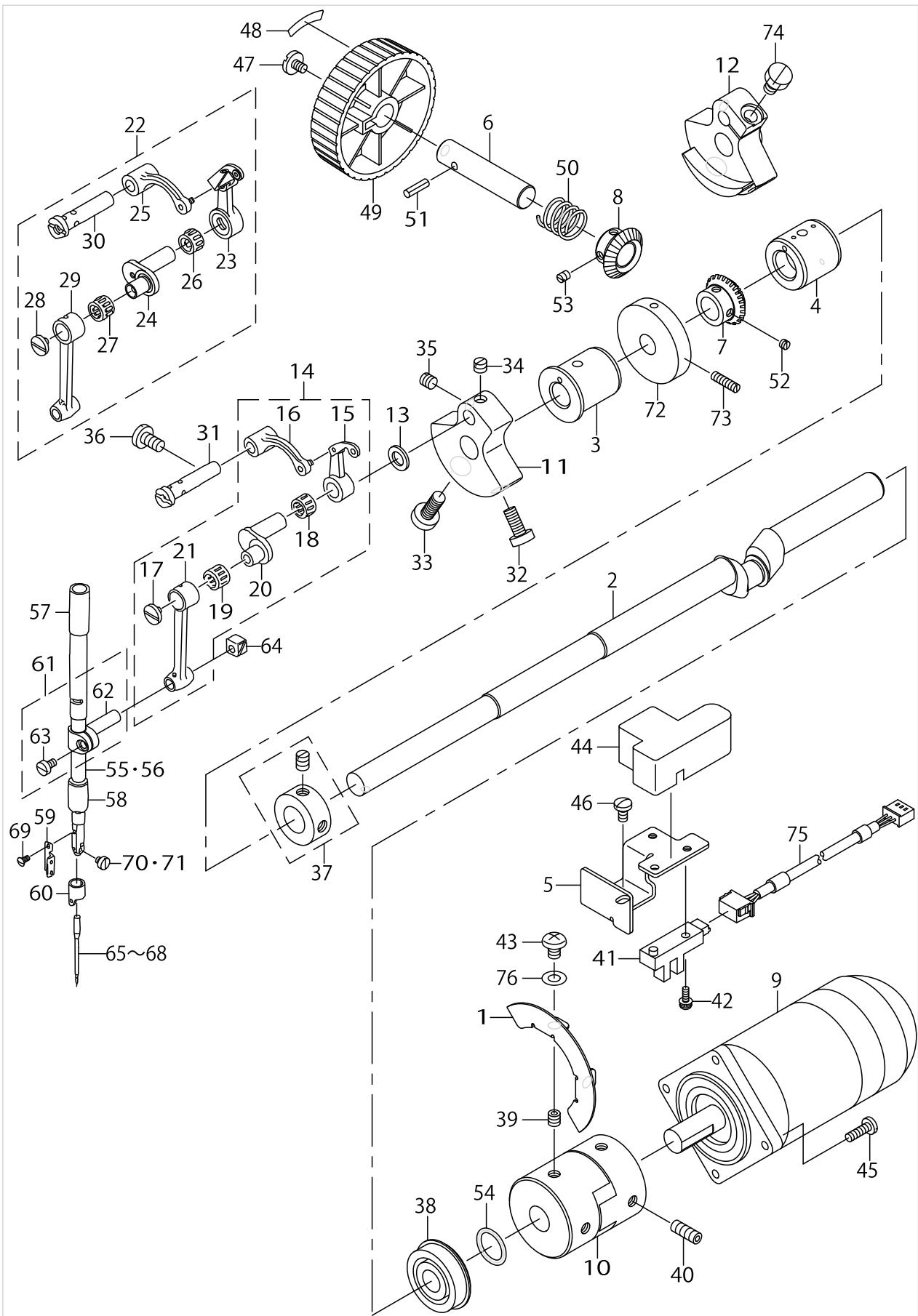

MAIM SHAFT & NEEDLE BAR COMPONENTS

No.	Parts No.	Parts name	Remarks	Level	Cons	Qty
1	14102404	MAIN SHAFT SLIT PLATE				1
2	14102107	MAIN SHAFT				1
3	14102206	MAIN SHAFT BUSHING, FRONT				1
4	14102305	MAIN SHAFT BUSHING, MIDDLE				1
5	14102503	SENSOR INSTALLING BASE				1
6	26500306	HAND PULLEY SHAFT				1
7	14102701	HAND PULLEY GEAR A				1
8	14102800	HAND PULLEY GEAR B				1
9	B1230210D00	MAIN MOTOR				1
10	B1231210D00	COUPLING				1
11	B1202280000	COUNTER WEIGHT	FOR LK-1900SS,HS,SA,HA			1
12	B1206210D00	COUNTER WEIGHT	FOR LK-1900FS,MS,FA,MA			1
13	B1223771000	NEEDLE ROD CRANK WASHER				1
14	B19012800B0	LINK BALANCE ASM.	FOR LK-1900SS,HS,SA,HA			1
15	B1901280000	THREAD TAKE-UP LEVER		*		1
16	B1903280000	THREAD TAKE-UP CRANK		*		1
17	B1903552000	LEFT SCREW		*		1
18	B1905541000	NEEDLE BUSHING		*		1
19	B1411804000	NEEDLE DRIVING LEVER BEARING		*		1
20	B1203280000	NEEDLE ROD CRANK		*		1
21	B1404280000	NEEDLE BAR CRANK ROD		*		1
22	B1901210DC0	LINK THREAD TAKE-UP	FOR LK-1900FS,MS,FA,MA			1
23	B1901210DA0	THREAD TAKE-UP LEVER COMPL.		*		1
24	B1407210D00	NEEDLE BAR CRANK		*		1
25	B1903210000	THREAD TAKE-UP CRANK		*		1
26	B1905541000	NEEDLE BUSHING		*		1
27	B1411804000	NEEDLE DRIVING LEVER BEARING		*		1
28	B1903552000	LEFT SCREW		*		1
29	B1404280000	NEEDLE BAR CRANK ROD		*		1
30	B1904280000	BALANCE CRANK PIN		*		1
31	B1904280000	BALANCE CRANK PIN	FOR LK-1900SS,HS,SA,HA			1
32	SS6151412TP	SCREW 15/64-28 L=14				1
33	SS6681712TP	SCREW 9/32-28 L=16.5				1
34	SS8660530TP	SCREW 1/4-40 L= 4.5	FOR LK-1900SS,HS,SA,HA			1
35	SS8660610TP	SCREW 1/4-40 L=6				1
36	SS7151120SP	SCREW 15/64-28 L=11				1
37	CS147121ASH	THRUST COLLAR ASM.D=14.72 W=12				1
38	G1216870000	UPPER SHAFT REAR BEARING				1
39	SM8060612TP	SCREW M6 L=6				2
40	SM8061612TP	SCREW M6X16				2
41	HD002230000	PHOTO SENSOR				1
42	SL4041291SC	SCREW M4 L=12				1
43	SM4060801SE	SCREW				2
44	14114508	MAIN SHAFT SENSOR COVER				1
45	SS7111410TP	SCREW 11/64-40 L=14				4
46	SS7110840SP	SCREW 11/64-40 L=7.8				1
47	A1230500000A	HANDWHEEL SETSCREW				1

MAIM SHAFT & NEEDLE BAR COMPONENTS

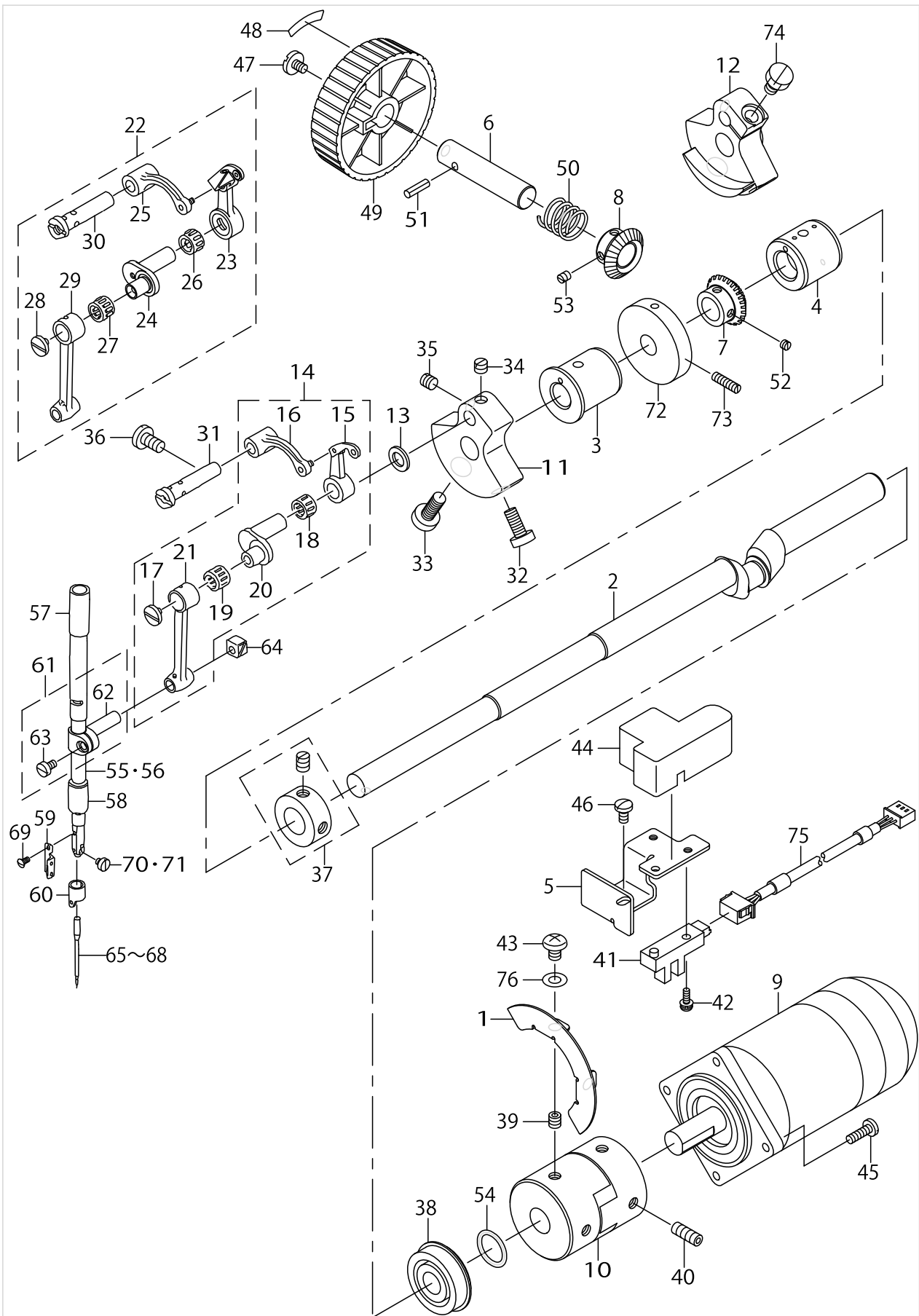

MAIM SHAFT & NEEDLE BAR COMPONENTS

No.	Parts No.	Parts name	Remarks	Level	Cons	Qty
48	B1144210000	REVOLVING DIRECTION LABEL				1
49	B1212210D00	PULLEY				1
50	GAF01007000	SPRING				1
51	PS0400142KH	SPRING PIN 4X14				1
52	SS8110310SP	SCREW 11/64-40 L= 2.8				2
53	SS8110310SP	SCREW 11/64-40 L= 2.8				2
54	RO154240100	RUBBER RING				1
55	B1401280000	NEEDLE BAR	FOR LK-1900SS,FS,MS,SA,FA,MA			1
56	D1401L7VV00	NEEDLE BAR	FOR LK-1900HS,HA			1
57	B1402280000	NEEDLE ROD METAL				1
58	B1403280000	NEEDLE ROD LOWER METAL				1
59	B1405280000	NEEDLE BAR THREAD GUIDE	FOR LK-1900SS,FS,MS,SA,FA,MA			1
60	D1405L7AM00	NEEDLE BAR THREAD GUIDE	FOR LK-1900HS,HA			1
61	B14115520A0	NEEDLE BAR CONNECTING ASM.				1
62	B1411552000	NEEDLE BAR CLAMP		*		1
63	SS6090670TP	SCREW 9/64-40 L=6		*		1
64	B1414232000	SQUARE BLOCK				1
65	MDP500B1100	NEEDLE DPX5 #11	FOR LK-1900FS,MS,FA,MA			1
66	MDP500B1400	NEEDLE DPX5 #14	FOR LK-1900SS,SA(USE IN JAPAN)			1
67	MDP500B1600	NEEDLE DPX5 #16	FOR LK-1900SS,SA(EXPORT)			1
68	MDP170B1900	NEEDLE DPX17 #19	FOR LK-1900HS,HA			1
69	SS2060510SP	SCREW 3/32-56 L=4.5	FOR LK-1900SS,FS,MS,SA,FA,MA			1
70	SS6080340SP	SCREW 1/8-44 L=2.9	FOR LK-1900SS,FS,MS,SA,FA,MA			1
71	SS7080510TP	SCREW 1/8-44 L=4.5	FOR LK-1900HS,HA			1
72	B3213205000	BOBBIN WINDER DRIVING WHEEL				1
73	SS8111610SP	SCREW 11/64-40 L=15.5				2
74	SS9661230CP	SCREW 1/4-40 L=12	FOR LK-1900FS,MS,FA,MA			1
75	14115356	MAIN SHAFT SENSOR CABLE ASM.				1
76	WS0610002KN	SPRING WASHER 6.1X12.2X1.5				2

PRESSER LIFTER COMPONENTS

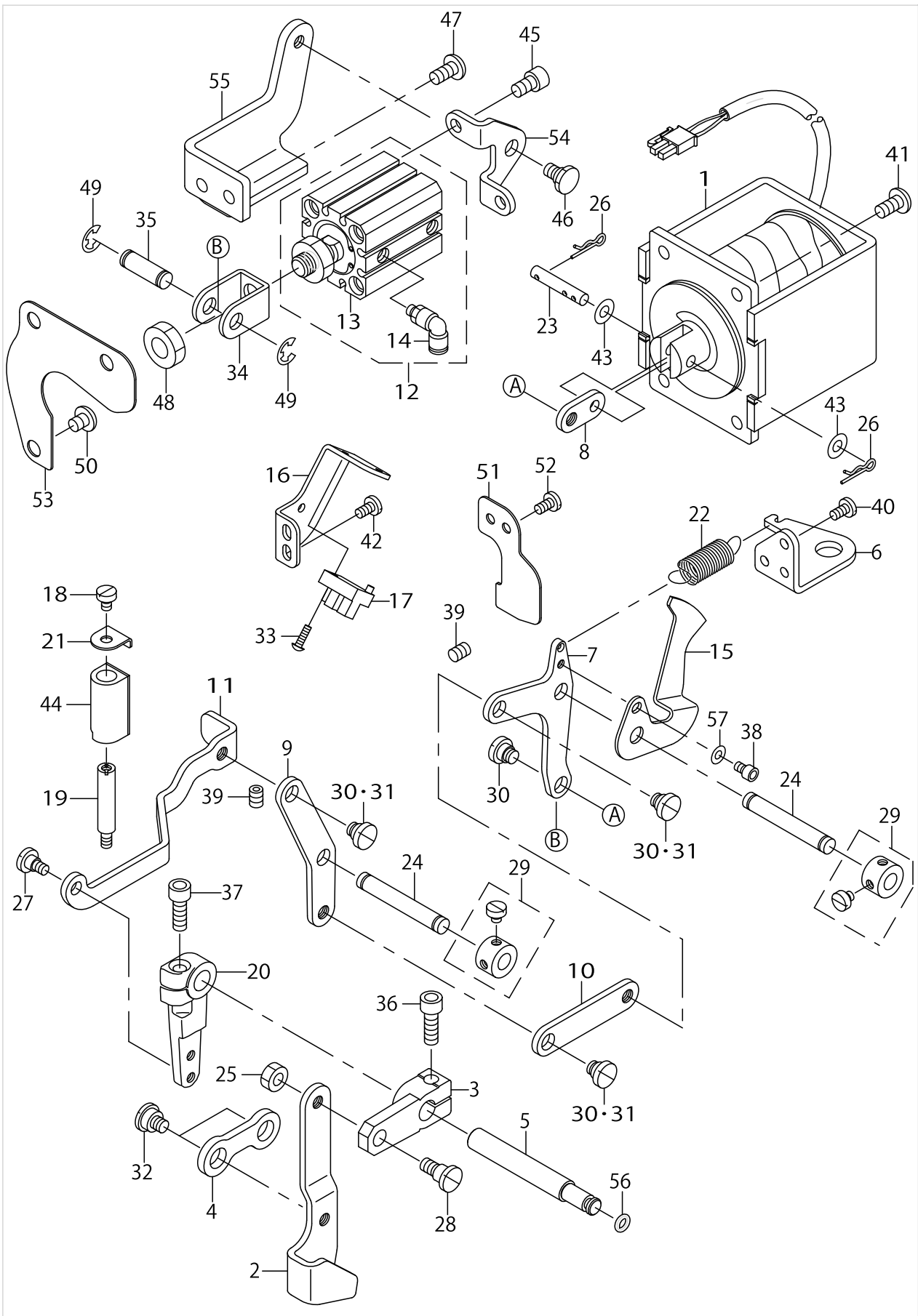

PRESSER LIFTER COMPONENTS

No.	Parts No.	Parts name	Remarks	Level	Cons	Qty
1	14104152	PRESSER LIFTING SOLENOID ASM.	FOR LK-1900SS,HS,FS,MS			1
2	14104202	LOWERING FOOT				1
3	14104301	LOWERING ARM				1
4	14104400	CONNECTING LINK				1
5	26500405	CONNECTING SHAFT				1
6	14104608	RETURN SPRING HOOK	FOR LK-1900SS,HS,FS,MS			1
7	26500801	LINK D				1
8	14104707	SOLENOID LINK	FOR LK-1900SS,HS,FS,MS			1
9	26500702	LINK B				1
10	14105001	LINK C				1
11	14104806	LINK A				1
12	14105852	PRESSER LIFTING CYLINDER ASM.	FOR LK-1900SA,HA,FA,MA			1
13	PA2502507A0	AIR CYLINDER		*		1
14	PJ304060502	ELBOW UNION 6XM5		*		2
15	14105209	PRESSER SENSOR SLIT				1
16	14105308	SENSOR INSTALLING PLATE				1
17	HD00057000A	PHOTO SENSOR				1
18	SS6110610TP	SCREW 11/64-40 L=6	FOR LK-1900SS,HS,FS,MS			1
19	22924005	PUMP BODY STRUT	FOR LK-1900SS,HS,FS,MS			1
20	13506415	CONNECTING ARM				1
21	14105704	STOPPER RUBBER SET WASHER	FOR LK-1900SS,HS,FS,MS			1
22	13544705	SPRING	FOR LK-1900SS,HS,FS,MS			1
23	B1513210D00	MAGNET PIN	FOR LK-1900SS,HS,FS,MS			1
24	D2502232D00	SHAFT BLOCK SHAFT				2
25	NS6150310SP	NUT 15/64-28				1
26	B1515210D00	PIN	FOR LK-1900SS,HS,FS,MS			2
27	SD0640391TP	HINGE SCREW D= 6.35 H= 3.9				1
28	SD0790601SP	HINGE SCREW D=7.94 H=6				1
29	CS079101ASH	THRUST COLLAR ASM. D=7.94 W=10				2
30	SD0800341SP	HINGE SCREW D=8 H=3.4	FOR LK-1900SS,HS,FS,MS			4
31	SD0800341SP	HINGE SCREW D=8 H=3.4	FOR LK-1900SA,HA,FA,MA			3
32	SD1000401SP	HINGE SCREW D=10 H= 4				2
33	SL4031291SC	SCREW M3X12				1
34	13860200	CYLINDER PUSHING PLATE	FOR LK-1900SA,HA,FA,MA			1
35	13860606	PIN	FOR LK-1900SA,HA,FA,MA			1
36	SM6061802TP	SCREW M6 L=18				1
37	SM6061802TP	SCREW M6 L=18				1
38	SM6040602TP	SCREW M4 L=6				1
39	SS8150822TP	SCREW 15/64-28 L=8				2
40	SS7110840SP	SCREW 11/64-40 L=7.8	FOR LK-1900SS,HS,FS,MS			2
41	SS4151215SP	SCREW 15/64-28 L=12	FOR LK-1900SS,HS,FS,MS			4
42	SS7110840SP	SCREW 11/64-40 L=7.8				2
43	WP0560860SE	WASHER 5.6X12X0.8	FOR LK-1900SS,HS,FS,MS			2
44	14105605	PRESSER LIFTING STOPPER RUBBER	FOR LK-1900SS,HS,FS,MS			1
45	SM6061602TP	SCREW M6 L=16	FOR LK-1900SA,HA,FA,MA			2
46	SD0800342TP	HINGE SCREW D=8 H=3.2	FOR LK-1900SA,HA,FA,MA			1
47	SS4151215SP	SCREW 15/64-28 L=12	FOR LK-1900SA,HA,FA,MA			2

PRESSER LIFTER COMPONENTS

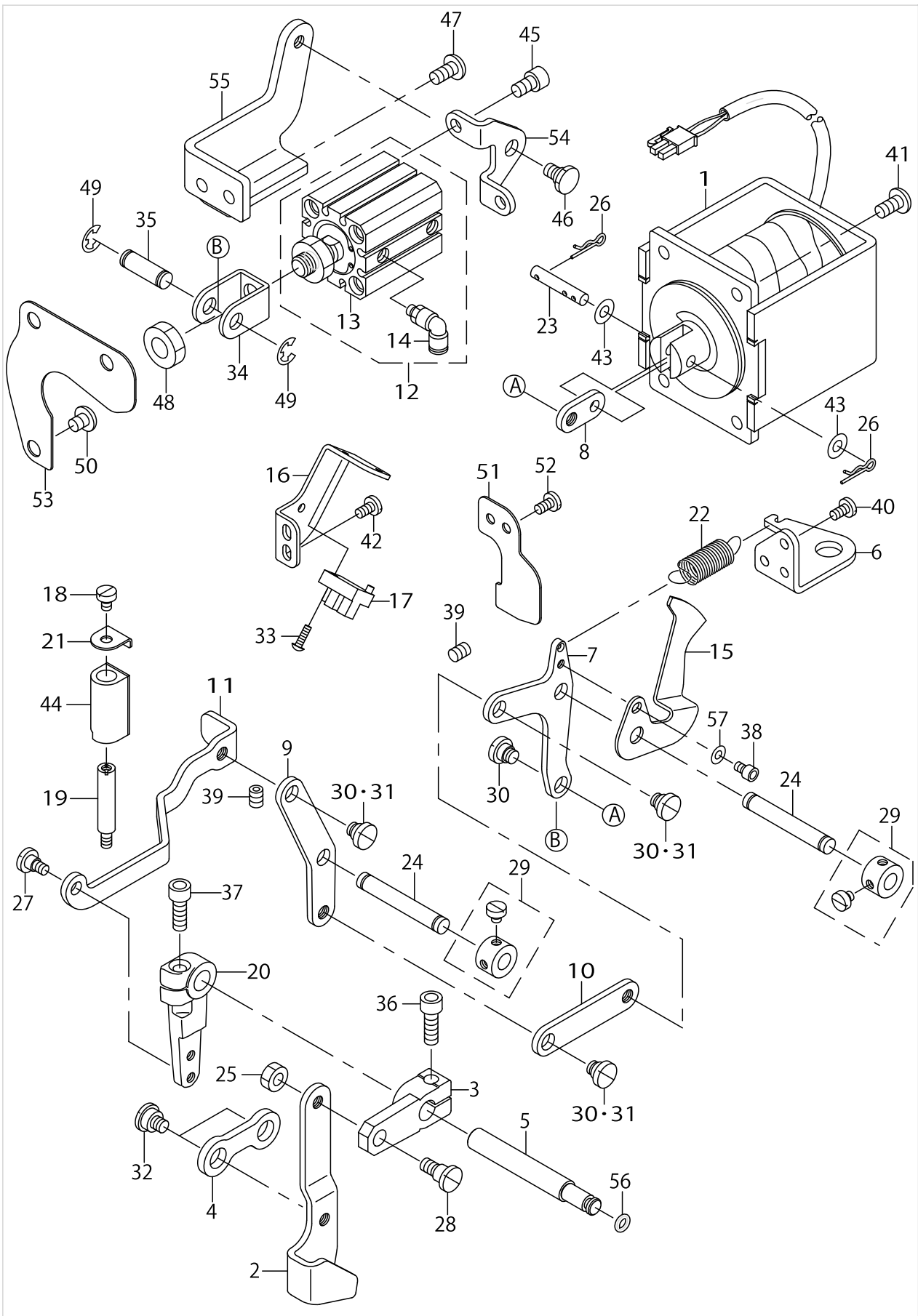

PRESSER LIFTER COMPONENTS

No.	Parts No.	Parts name	Remarks	Level	Cons	Qty
48	NM6540023SB	NUT	FOR LK-1900SA,HA,FA,MA			1
49	RE0600000K0	E-RING 6	FOR LK-1900SA,HA,FA,MA			2
50	SS4150715SP	SCREW 15/64-28 L=7	FOR LK-1900SA,HA,FA,MA			3
51	14105506	PLATE				1
52	SS7110840SP	SCREW 11/64-40 L=7.8				2
53	14106108	PLATE	FOR LK-1900SA,HA,FA,MA			1
54	14105902	CYLINDER BASE A	FOR LK-1900SA,HA,FA,MA			1
55	14106009	CYLINDER BASE B	FOR LK-1900SA,HA,FA,MA			1
56	RO048190100	RUBBER RING				1
57	WP0450801SD	WASHER 4.5X10X0.8				1

SHUTTLE DRIVER SHAFT COMPONENTS

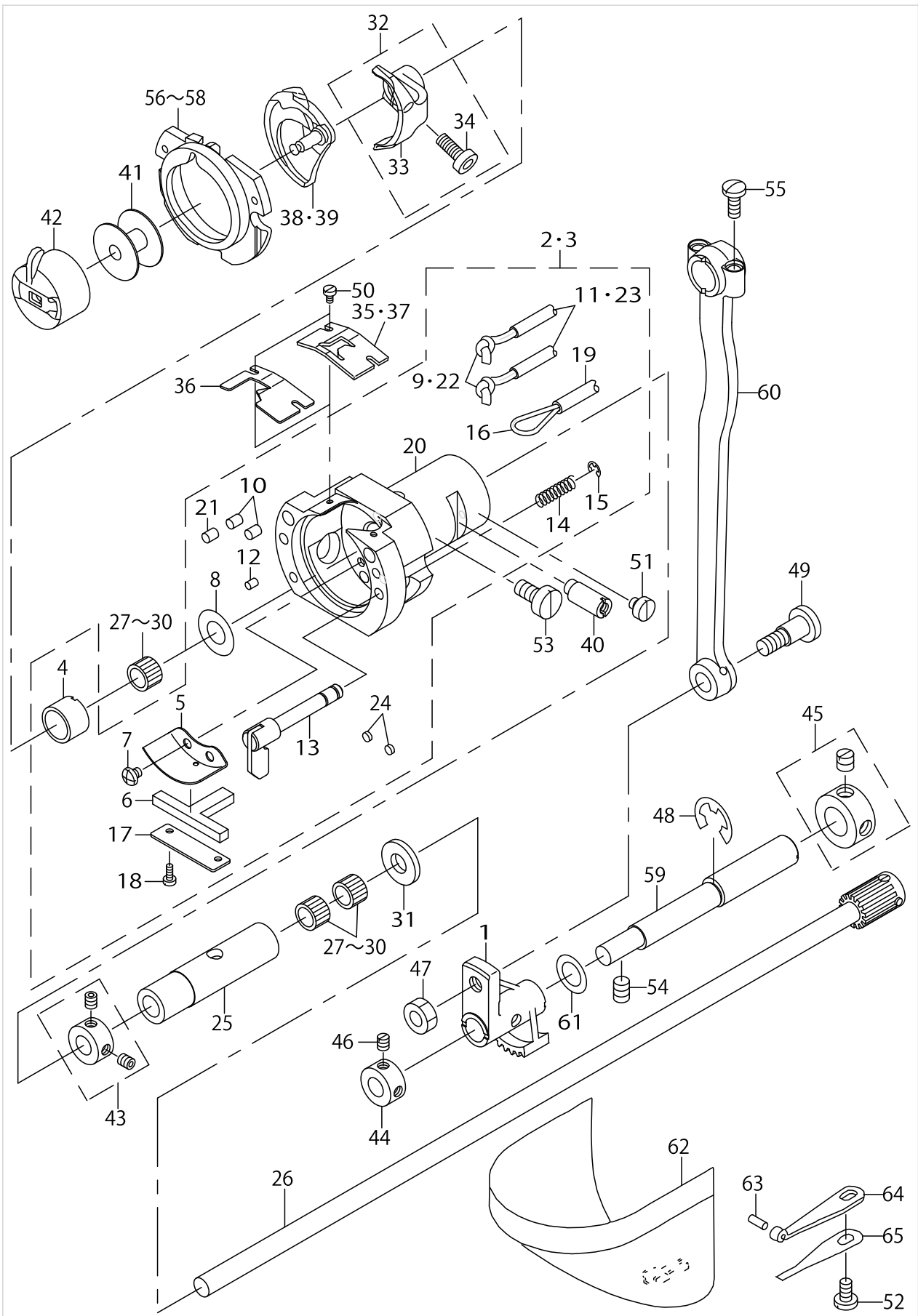

SHUTTLE DRIVER SHAFT COMPONENTS

No.	Parts No.	Parts name	Remarks	Level	Cons	Qty
1	14106702	OSCILLATOR				1
2	14103758	SHUTTLE ASM.	FOR LK-1900SS,HS,SA,HA			1
3	40011409	SHUTTLE ASM.	FOR LK-1900FS,MS,FA,MA			1
4	14106405	SHUTTLE NEEDLE OUTER RING		*		1
5	26231100	SHUTTLE LUBRICATING PLATE		*		1
6	14103907	SHUTTLE ONCE THROUGH OIL FELT		*		1
7	SS4090415SP	SCREW 9/64-40 L=4		*		2
8	WP0952616SD	WASHER 9.5X14.8X2.6		*		1
9	CQ202000000	OIL WICK		*		1.06
10	B1820210D00	SHUTTLE OIL FELT,A		*		2
11	23630007	TUBE		*		0.66
12	B1821210D00	SHUTTLE OIL FELT,B		*		1
13	26501858	INNER-HOOK-PRESSER COMPL.		*		2
14	B1822215P00	INNER HOOK PRESSER SPRING		*		2
15	RE0300000K0	E-RING 3		*		2
16	CQ200000000	OIL WICK		*		0.43
17	14104004	ONCE THROUGH OIL FELT PRESSER		*		1
18	SS6060410TP	SCREW 3/32-56 L= 3.5		*		2
19	BT0500300EA	OIL TUBE		*		0.19
20	14103006	SHUTTLE		*		1
21	22814909	FELT	FOR LK-1900FS,MS,FA,MA	*		1
22	CQ202000000	OIL WICK	FOR LK-1900SS,HS,SA,HA	*		1.59
23	23630007	TUBE	FOR LK-1900SS,HS,SA,HA	*		0.99
24	13529607	SHUTTLE PACKING		*		2
25	14106306	LOWER SHAFT REAR METAL				1
26	14106256	LOWER SHAFT GEAR ASM.				1
27	SB30800100A	BEARING	SELECTIVE PARTS			3
28	SB30800100B	BEARING	SELECTIVE PARTS			3
29	SB30800100C	BEARING	SELECTIVE PARTS			3
30	SB30800100D	BEARING	SELECTIVE PARTS			3
31	B1808980000	LOWER SHAFT THRUST WASHER				1
32	B18129800A0	DRIVER ASM.				1
33	B1812980000	SHUTTLE DRIVER		*		1
34	SS6121212TP	SCREW 3/16-28 L=12.0		*		1
35	B1815980000	SHUTTLE UPPER SPRING	FOR LK-1900SS,HS,SA,HA			1
36	14103501	SHUTTLE UPPER SPRING (F TYPE)	FOR LK-1900FS,MS,FA,MA			1
37	B1816980000	AUXILIARY SHUTTLE RACE SPRING	FOR LK-1900FS,MS,FA,MA			1
38	B1818280000	INNER HOOK	FOR LK-1900SS,FS,MS,SA,FA,MA			1
39	D1818282N00	SHUTTLE	FOR LK-1900HS,HA			1
40	26222208	SHUTTLE RACE ADJUSTING SHAFT				1
41	13812102	BOBBIN				1
42	B18289800BB	BOBBIN CASE ASM. (RACING PREVE				1
43	CS080081CSH	THRUST COLLAR ASM. D=8.0 W=8				1
44	CS1000811SP	THRUST COLLAR				1
45	CS1201010SH	THRUST COLLAR ASM. D=12 W=10				1
46	SS8110520TP	SCREW 11/64-40 L= 4.5				2
47	NS6660430SP	NUT 1/4-40				1

SHUTTLE DRIVER SHAFT COMPONENTS

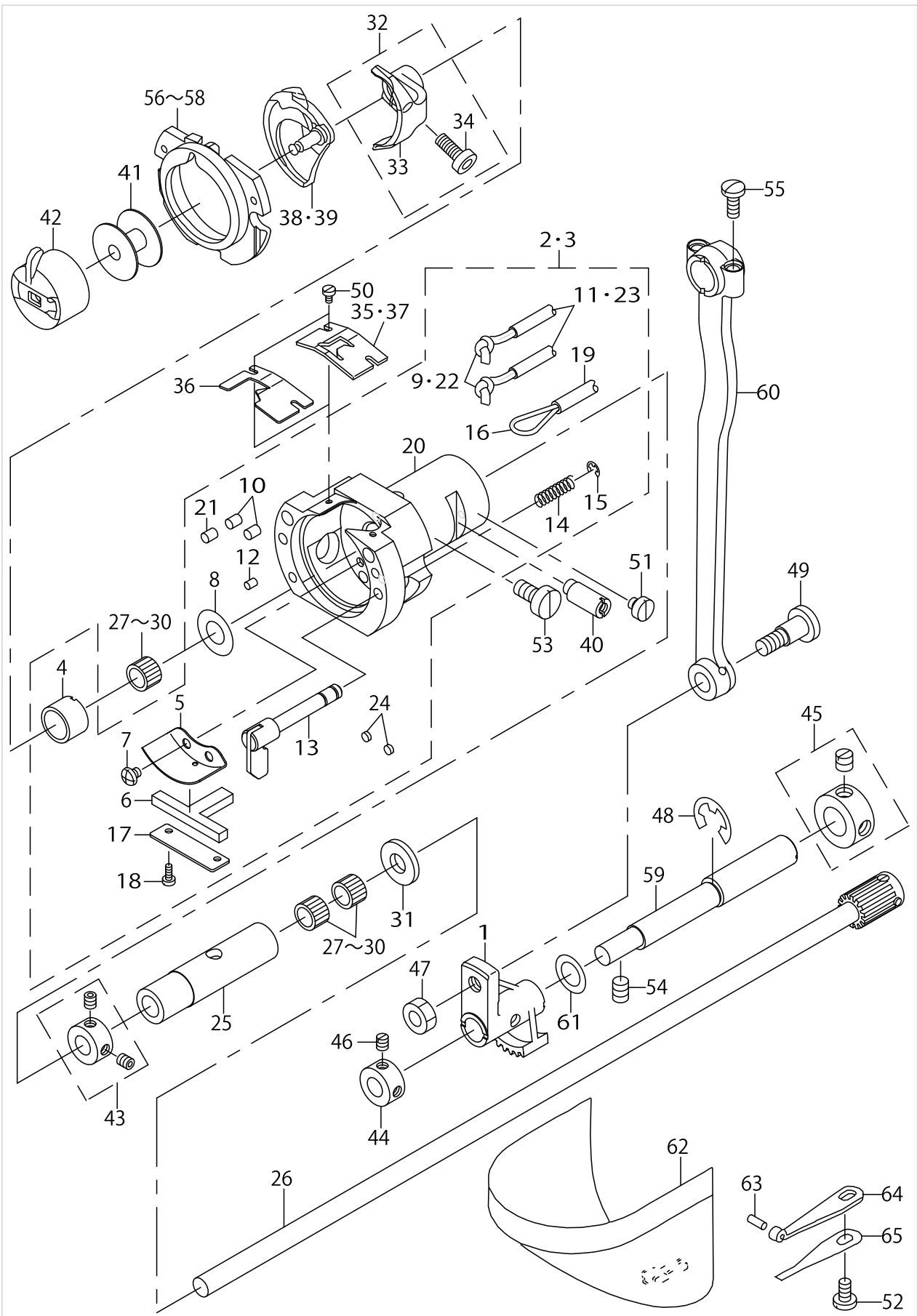

SHUTTLE DRIVER SHAFT COMPONENTS

No.	Parts No.	Parts name	Remarks	Level	Cons	Qty
48	RE090000K0	E-RING 9				1
49	SD0801021TP	HINGE SCREW D= 8 H=10.2				1
50	SS6060410TP	SCREW 3/32-56 L= 3.5				2
51	SS6110480SP	SCREW 11/64-40 L=4.3				1
52	SS7110840SP	SCREW 11/64-40 L=7.8				1
53	SS6151220SP	SCREW 15/64-28 L=11.5				1
54	SS8150822TP	SCREW 15/64-28 L=8				2
55	SS7111110TP	SCREW 11/64-40 L=10.5				2
56	14103659	SHUTTLE RACE RING ASM.,C	FORLK-1900HS,HA			1
57	14103253	INNER HOOK PRESSER ASM., A	FOR LK-1900FS,MS,FA,MA			1
58	14103352	INNER HOOK PRESSER ASM., B	FORLK-1900SS,SA			1
59	B1836210D00	OSCILLATING ECCENTRIC SHAFT				1
60	B1802210D00	CRANK ROD				1
61	10523504	WASHER				1
62	13816855	CYLINDER ARM CAP				1
63	13508700	HOOK COVER PRESSER SPRING PIN				1
64	13508809	HOOK COVER PRESSER SPRING A				1
65	13508908	HOOK COVER PRESSER SPRING B				1

WIPER MECHANISM COMPONENTS

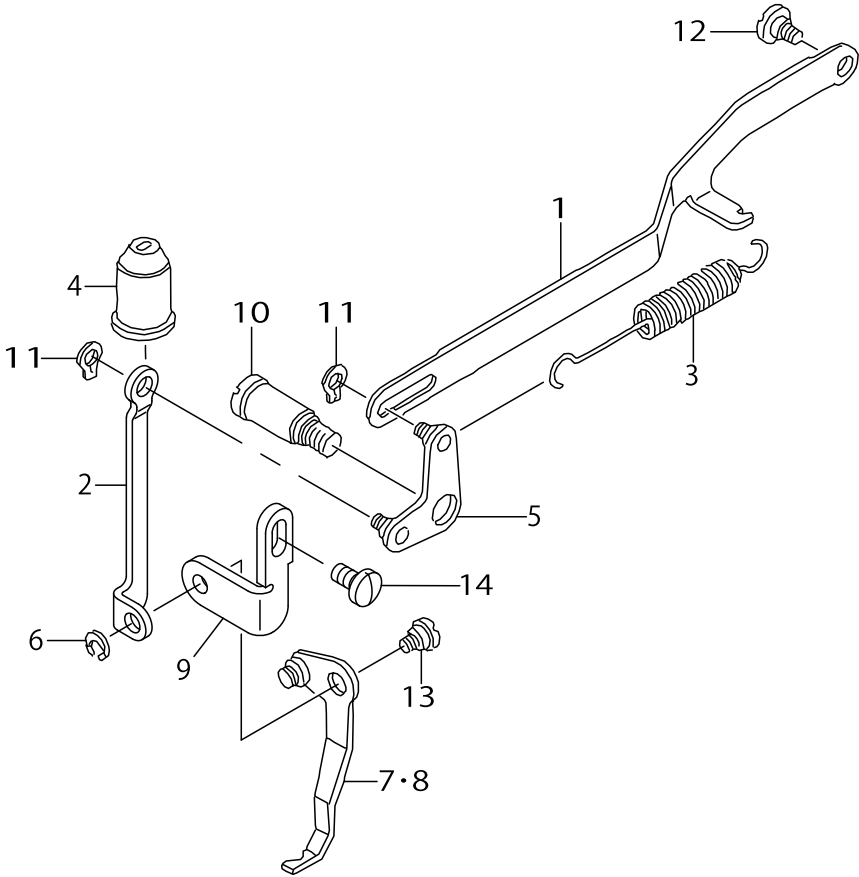

WIPER MECHANISM COMPONENTS

No.	Parts No.	Parts name	Remarks	Level	Cons	Qty
1	13509500	WIPER CONNECTING LINK				1
2	26217901	WIPER CONNECTING PLATE				1
3	13509708	SPRING				1
4	13509807	OIL SHIELD CAP				1
5	13509955	WIPER CONNECTING ARM ASM.				1
6	B1229232000	SNAP RING				1
7	B21012800A0	WIPER ASM.	FOR LK-1900SS,FS,MS,SA,FA,MA			1
8	D2101L7AMA0	WIPER ASM.	FOR LK-1900HS,HA			1
9	13574009	WIPER BASE PLATE				1
10	B2109280000	WIPER CONNECTING SCREW				1
11	RC0470611KP	RETAINING RING 4.7				2
12	SD0530221SP	HINGE SCREW D= 5.3 H= 2.2				1
13	SD0640211SP	HINGE SCREW D= 6.35 H= 2.1				1
14	SS7110840SP	SCREW 11/64-40 L=7.8				1

TENSION RELEASE & THREAD TENSION COMPONENTS

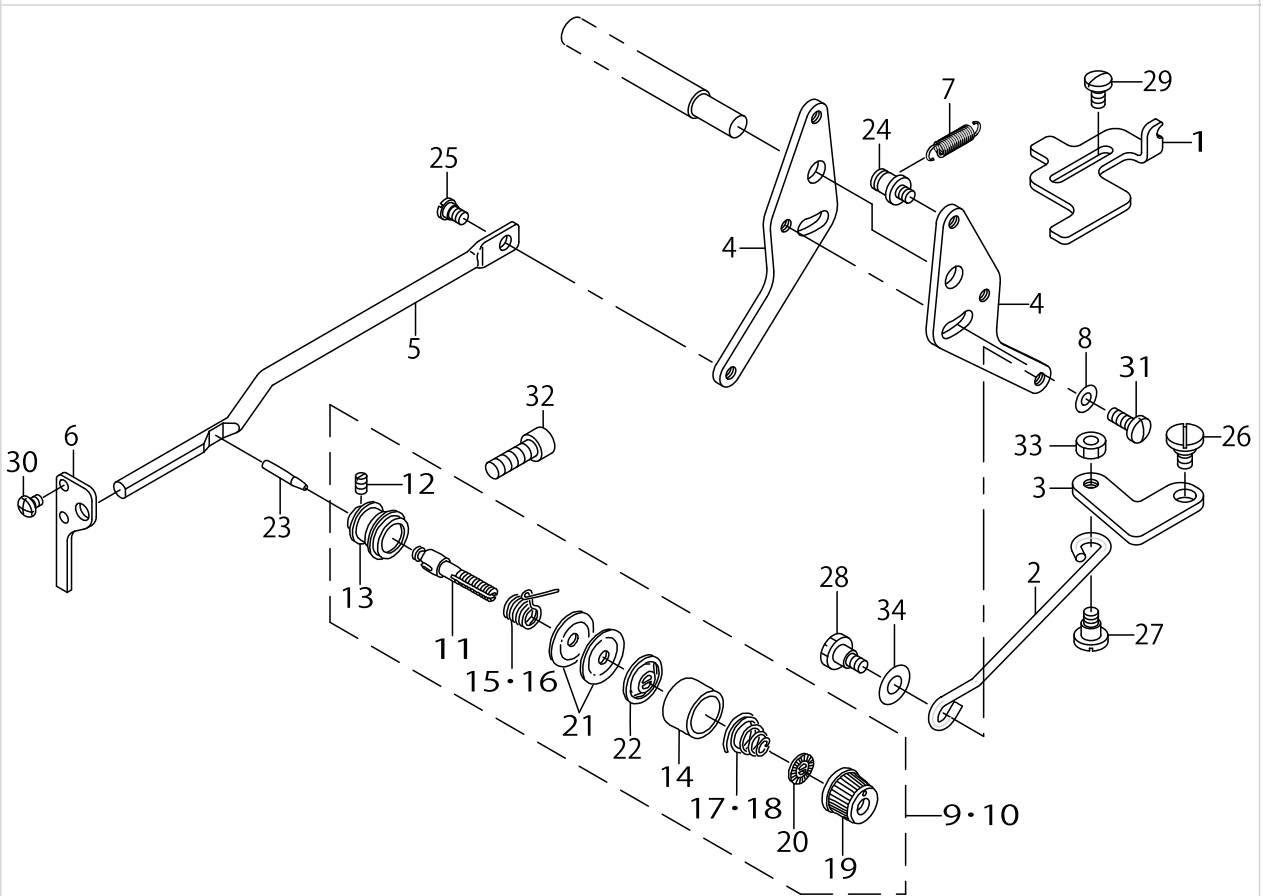

TENSION RELEASE & THREAD TENSION COMPONENTS

No.	Parts No.	Parts name	Remarks	Level	Cons	Qty
1	14107502	STOPPER				1
2	14107700	CONNECTING BAR				1
3	B2304210D00	TENSION RELEASE LINK				1
4	26500900	TENSION RELEASE ADJUSTING ARM				2
5	26501304	TENSION RELEASE BAR				1
6	13513304	THREAD TENSION ARM				1
7	B2545280000	PRESSURE SPRING				1
8	WP0482086SD	WASHER 4.8X11.5X2				1
9	B23022800A0	SECOND THREAD TENSION ASM.	FOR LK-1900SS,FS,MS,SA,FA,MA			1
10	B23022050A0	TENSION CONTROLLER NO.2 ASM.	FOR LK-1900HS,HA			1
11	B2302280000	SECOND THREAD TENSION ROD		*		1
12	SS8090610SP	SCREW 9/64-40 L=5.9		*		1
13	B2313280000	THREAD TENSION ROD, LARGE		*		1
14	B3107804000	THREAD TENSION DISK PRESSER		*		1
15	B3112761000	THREAD TAKE-UP SPRING		*		1
16	D3112L4BB00	TAKE-UP SPRING (HEAVY)		*		1
17	B3114232000	THREAD TENSION SPRING		*		1
18	B3129053000	TENSION SPRING		*		1
19	B3119771000	THREAD TENSION NUT		*		1
20	B3120125000	ROTATING STOPPER		*		1
21	B3126012000	THREAD TENSION DISK		*		2
22	B3132552000	THREAD TENSION DISK PRESSER		*		1
23	B2303280000	TENSION RELEASE PIN				1
24	B3413552000	SUSPENSION SCREW				1
25	SD0530221SP	HINGE SCREW D= 5.3 H= 2.2				1
26	SD0720321TP	HINGE SCREW				1
27	SD0640391TP	HINGE SCREW D= 6.35 H= 3.9				1
28	SD0640482SP	HINGE SCREW D= 6.35 H= 4.8				1
29	SS6110810TP	SCREW 11/64-40 L=8				2
30	SS4090515SP	SCREW 9/64-40 L=5				2
31	SS7111120TP	SCREW				1
32	SS6151812TP	SCREW 15/64-28 L=18				1
33	NS6120310SP	NUT 3/16-28				1
34	WP0651056SD	WASHER 6.5X11X1				1

TENSION RELEASE & THREAD TRIMMER MECHANISM COMPONENTS

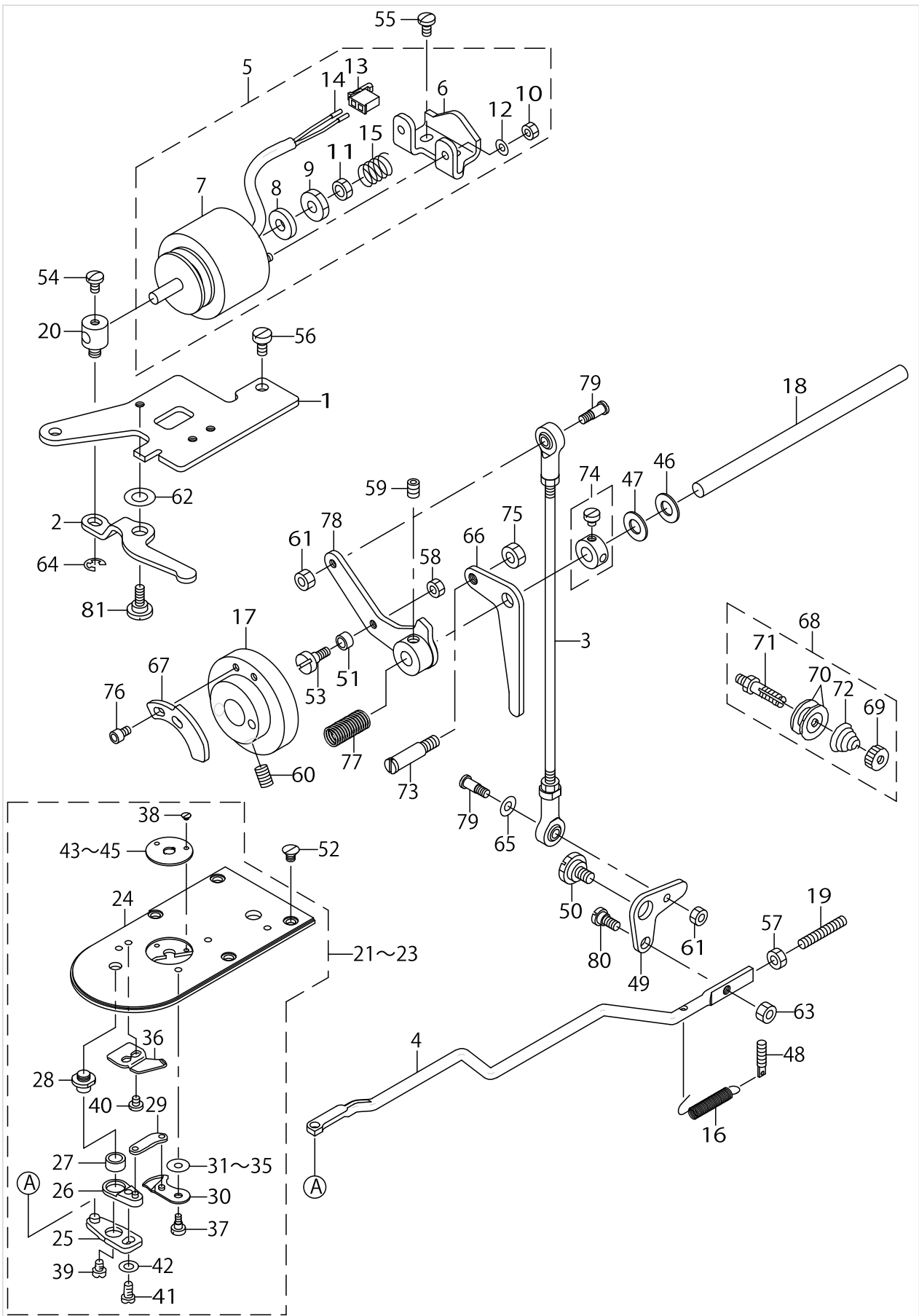

TENSION RELEASE & THREAD TRIMMER MECHANISM COMPONENTS

No.	Parts No.	Parts name	Remarks	Level	Cons	Qty
1	26501205	CAM FOLLOWER STOPPER				1
2	14108500	SOLENOID ARM				1
3	14108609	CONNECTING ROD				1
4	26501908	CONNECTING BAR				1
5	14108955	THREAD TRIMMING SOLENOID ASM.				1
6	14108807	SOLENOID INSTALLING BASE		*		1
7	14108906	SOLENOID FOR THREAD TRIMMING		*		1
8	11043304	SOLENOID RUBBER		*		1
9	NS6660410SH	NUT		*		1
10	NM6040000SN	NUT M4		*		2
11	NS6660430SP	NUT 1/4-40		*		1
12	WP0450000SD	WASHER 4.5X8X0.5		*		2
13	HK034610020	2-POLE NYLON PLUG		*		1
14	HK034640000	PIN CONTACT		*		2
15	B1652704000	SPRING		*		1
16	14109300	THREAD TRIM LINK SPRING				1
17	B2401210D00	THREAD TRIMMER CAM				1
18	B2408210D00	THREAD TRIMMER SHAFT				1
19	SM8053002TP	SCREW M5 L=30				1
20	11043007	SOLENOID PIN				1
21	14109755	NEEDLE PLATE ASM.,H	FORLK-1900HS,HA			1
22	13515556	NEEDLE PLATE ASM.	FORLK-1900SS,SA			1
23	13556154	NEEDLE PLATE ASM.,E				1
24	13515507	NEEDLE PLATE		*		1
25	B24142800A0	THREAD CUTTER LEVER ASM., LARG		*		1
26	B24152800A0	THREAD CUTTER LEVER ASM., SMAL		*		1
27	B2416280000	THREAD CUTTING LEVER RING		*		1
28	B2417280000	THREAD CUTTER LEVER SHAFT		*		1
29	B2418280000	MOVING KNIFE LINK		*		1
30	B24212800A0	MOVING KNIFE ASM.		*		1
31	B242328000A	MOVING KNIFE WASHER A	SELECTIVE PARTS	*		1
32	B242328000B	MOVING KNIFE WASHER B	SELECTIVE PARTS	*		1
33	B242328000C	MOVING KNIFE WASHER C	SELECTIVE PARTS	*		1
34	B242328000D	MOVING KNIFE WASHER D	SELECTIVE PARTS	*		1
35	B242328000E	MOVING KNIFE WASHER E	SELECTIVE PARTS	*		1
36	B2424280000	FIXING KNIFE		*		1
37	SD0500091TP	HINGE SCREW D= 5.0 H= 0.9		*		1
38	SS1060210TP	SCREW 3/32-56 L=2.2		*		2
39	SS6110430TP	SCREW 11/64-40 L= 4.0		*		1
40	SS7090410SP	SCREW 9/64-40 L= 3.5		*		2
41	SS7110740TP	SCREW 11/64-40 L=7		*		1
42	WP0450846SP	WASHER		*		1
43	B2426280000	NEEDLE HOLE GUIDE	FORLK-1900SS,SA	*		1
44	14109607	NEEDLE HOLE GUIDE	FORLK-1900HS,HA	*		1
45	D2426282C00	NEEDLE HOLE GUIDE		*		1
46	B1223771000	NEEDLE ROD CRANK WASHER				1
47	B1116804000	CLOTH PLATE WASHER				1

TENSION RELEASE & THREAD TRIMMER MECHANISM COMPONENTS

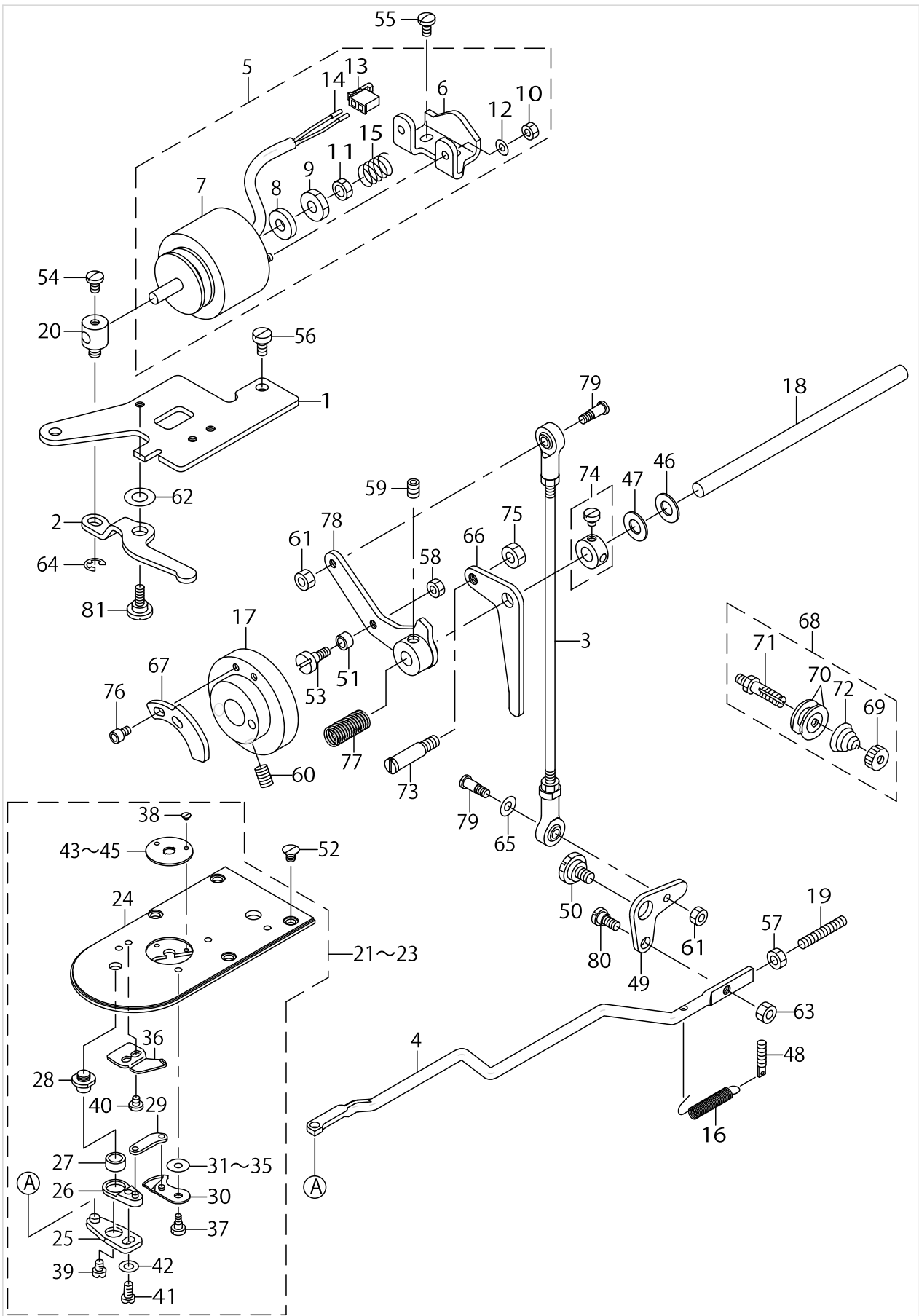

TENSION RELEASE & THREAD TRIMMER MECHANISM COMPONENTS

No.	Parts No.	Parts name	Remarks	Level	Cons	Qty
48	B1649161000	TENSION SPRING ADJUSTING SCREW				1
49	B2411210000	THREAD TRIMMER LINK				1
50	SD1100301TP	HINGE SCREW H=11 W=3				1
51	D2587L8WB00	ROLLER				1
52	SS1110640TP	SCREW 11/64-40 L= 5.5				4
53	D2588L8WB00	ROLLER SHAFT				1
54	SS7110740TP	SCREW 11/64-40 L=7				1
55	SS7110840SP	SCREW 11/64-40 L=7.8				2
56	SS6120930SP	SCREW 3/16-28 L=9				2
57	NM6050001SP	NUT M5				1
58	NS6110420SP	NUT 11/64-40				1
59	SS8150822TP	SCREW 15/64-28 L=8				1
60	SS8661012TP	SCREW				2
61	NS6110420SP	NUT 11/64-40				2
62	WP0553216SD	WASHER				1
63	NS6120310SP	NUT 3/16-28				1
64	RE0500000K0	E-RING				1
65	WP0501016SD	WASHER 5X10.5X1				1
66	14107601	THREAD RELEASE ARM				1
67	B2312210D00	TENSION RELEASE NOTCH				1
68	B11152320A0	FIRST THREAD TENSION ASM.				1
69	A3125002000	TENSION NUT, NO.1		*		1
70	B3126012000	THREAD TENSION DISK		*		2
71	B3123352000	THREAD TENSION ROD		*		1
72	B1115232000	FIRST THREAD TENSION SPRING		*		1
73	26500504	TENSION RELEASE ARM PIN				1
74	CS080081BSH	THRUST COLLAR ASM. D=8.0 W=8				1
75	NS6150310SP	NUT 15/64-28				1
76	SM6040602TP	SCREW M4 L=6				2
77	B2617771000	TRIPPING LEVER TENSION SPRING				1
78	14109250	CAM FOLLOWER ASM.				1
79	SD0500803TP	HINGE SCREW D=5 H=8				2
80	SD0650305TP	HINGE SCREW D= 6.5 H= 3				1
81	SD0790311TP	HINGE SCREW D= 7.94 H= 3.1				1

FEED MECHANISM COMPONENTS

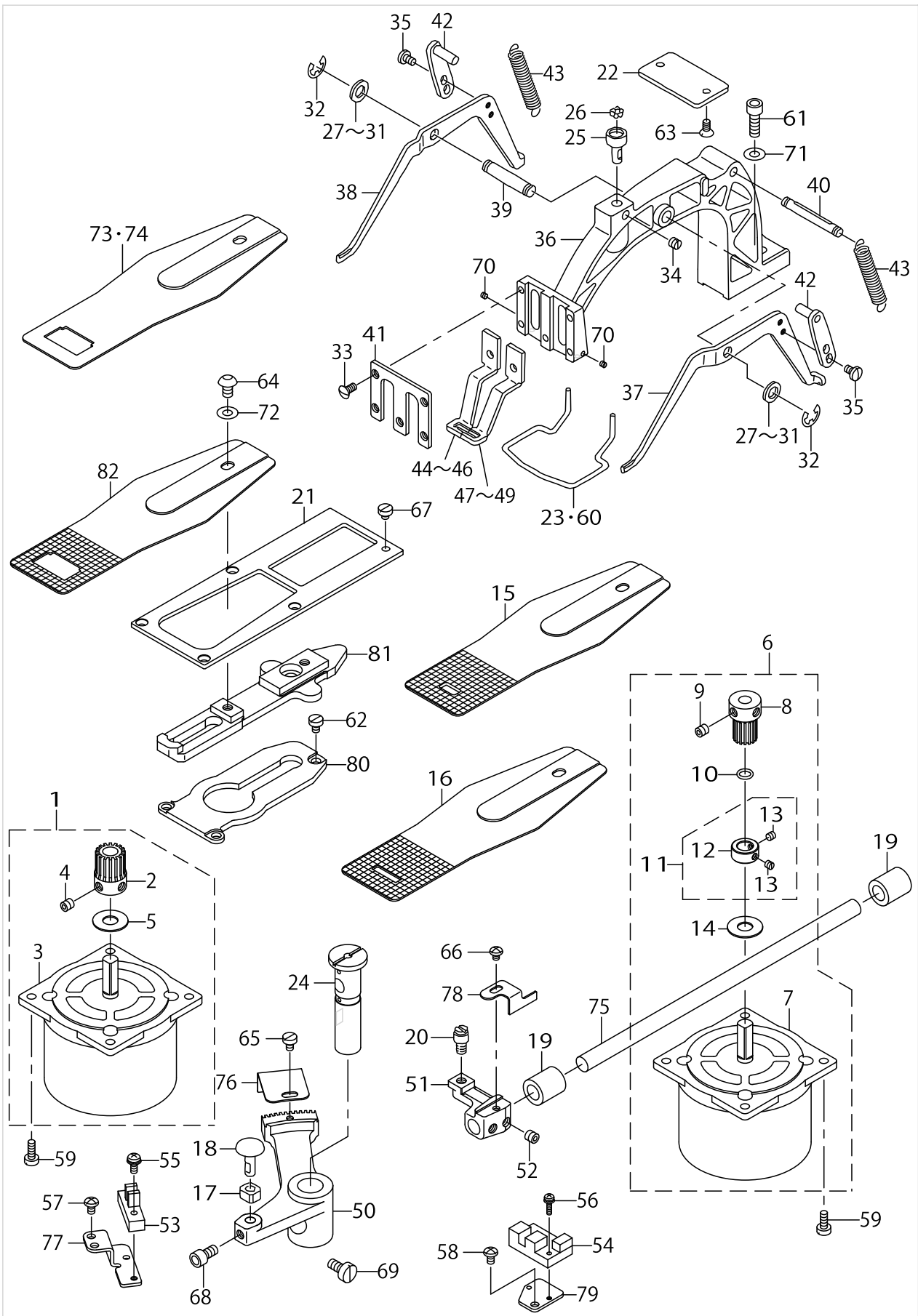

FEED MECHANISM COMPONENTS

No.	Parts No.	Parts name	Remarks	Level	Cons	Qty
1	14112353	X FEED MOTOR ASM.				1
2	26501403	X FEED GEAR		*		1
3	14112304	X FEED STEPPING MOTOR		*		1
4	SM8060612TP	SCREW M6 L=6		*		2
5	14112502	RUBBER WASHER		*		1
6	14112452	Y FEED MOTOR ASM.				1
7	14112403	Y FEED STEPPING MOTOR		*		1
8	26501502	Y FEED GEAR		*		1
9	SM8060612TP	SCREW M6 L=6		*		2
10	RO069180100	RUBBER RING		*		1
11	CS095081ASH	THRUST COLLAR ASM. D=9.53 W=8		*		1
12	CS0950817SH	THRUST COLLAR D=9.53 W=8		*		1
13	SS8110410TP	SCREW 11/64-40 L= 3.5		*		2
14	14112502	RUBBER WASHER		*		1
15	14116206	FEED PLATE B	FOR LK-1900MS,MA			1
16	13554803	FEED PLATE	FOR LK-1900HS,HA			1
17	B1414232000	SQUARE BLOCK				1
18	13517206	SLIDE BLOCK STUD				1
19	B2509704000	BUSHING, REAR				2
20	13517404	HINGE STUD				1
21	26500603	CLOTH FEED PRESSER PLATE				1
22	13518907	SUPPORT PLATE				1
23	13533104	FINGER GUARDE	EXCEPT LK-1900HS,HA			1
24	13516208	FEED DRIVING ARM SHAFT				1
25	B2548280000	BALL RETAINER				1
26	B2549280000	WORK CLAMP FOOT MOUNTING BASE				7
27	B255728000A	WASHER A	SELECTIVE PART			2
28	B255728000B	WASHER B	SELECTIVE PART			2
29	B255728000C	WASHER C	SELECTIVE PART			2
30	B255728000D	WASHER D	SELECTIVE PART			2
31	B255728000E	WASHER	SELECTIVE PART			2
32	RE0700000K0	E-RING 7				2
33	SS2110930SP	SCREW 11/64-40 L=8.7				5
34	SS8150510TP	SCREW 15/64-28 L= 4.7				1
35	SS7110740TP	SCREW 11/64-40 L=7				4
36	13517800	FEED BRACKET				1
37	26204008	LIFTING LEVER RIGHT				1
38	26204107	LIFTING LEVER LEFT				1
39	13518105	LIFTING LEVER SHAFT				1
40	13518501	SPRING SUSPENSION				1
41	26224105	WORK CLAMP FOOT FACE PLATE				1
42	13518352	LEVER DRIVING PLATE ASM.				2
43	14105407	CLOTH PRESSER SPRING				2
44	13518600	WORK CLAMP FOOT, RIGHT	FOR LK-1900SS,FS,SA,FA			1
45	13542915	WORK CLAMP FOOT, RIGHT	FOR LK-1900MS,MA			1
46	13548102	WORK CLAMP FOOT, RIGHT	FOR LK-1900HS,HA			1
47	13518709	WORK CLAMP FOOT, LEFT	FOR LK-1900SS,FS,SA,FA			1

FEED MECHANISM COMPONENTS

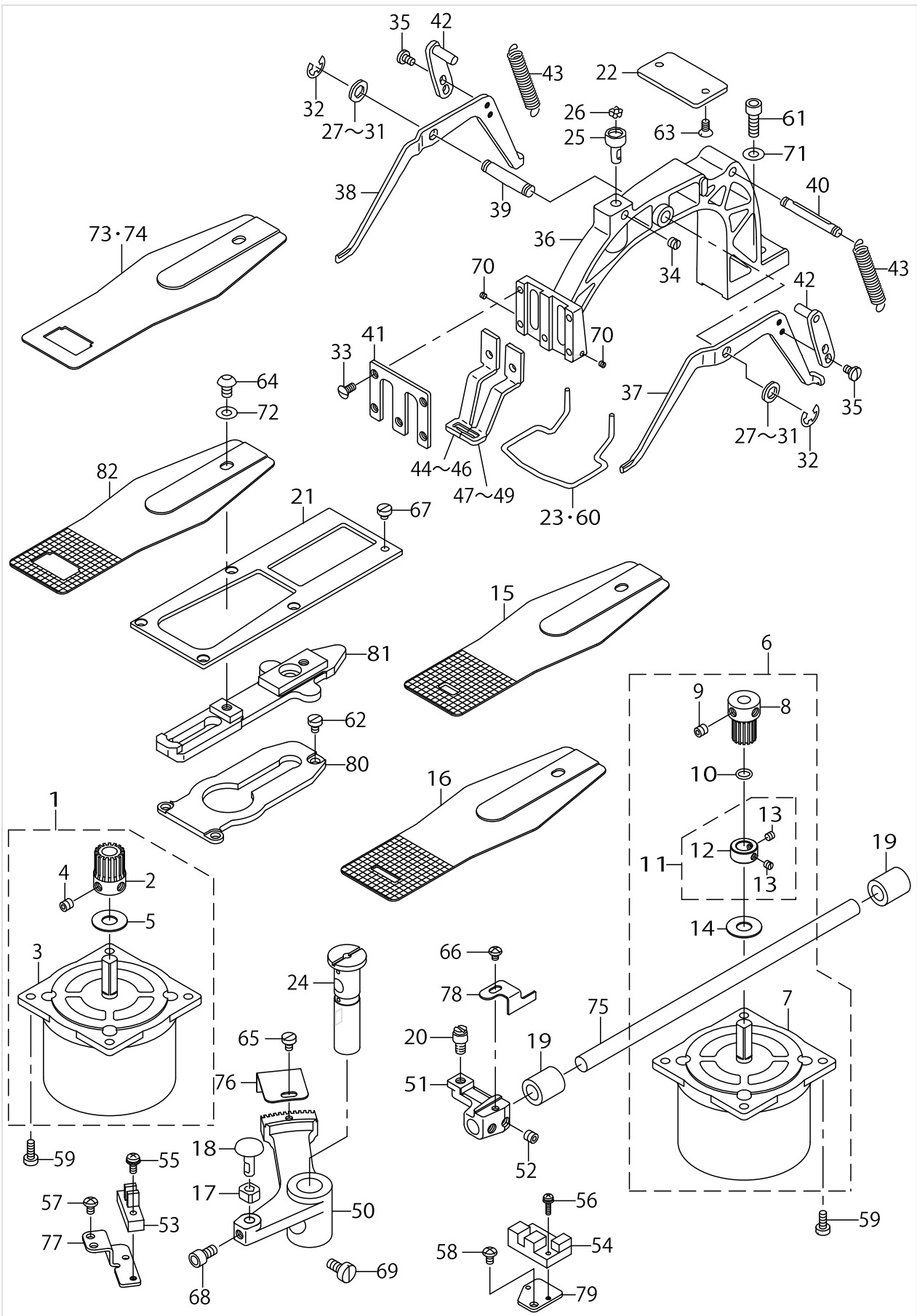

FEED MECHANISM COMPONENTS

No.	Parts No.	Parts name	Remarks	Level	Cons	Qty
48	13543012	WORK CLAMP FOOT, LEFT	FOR LK-1900MS,MA			1
49	13548201	WORK CLAMR FOOT LEFT	FOR LK-1900HS,HA			1
50	14110001	CROSSFEED ARM				1
51	26500009	Y FEED ARM				1
52	SS8660612TP	SCREW 1/4-40 L=6				2
53	HD002230000	PHOTO SENSOR				1
54	HD00057000A	PHOTO SENSOR				1
55	SL4041291SC	SCREW M4 L=12				1
56	SL4031291SC	SCREW M3X12				1
57	SS4110715SP	SCREW 11/64-40 L=7				2
58	SS4110715SP	SCREW 11/64-40 L=7				1
59	SS6111140SP	SCREW 11/64-40 L=11				8
60	13548300	FINGER GUARD	FOR LK-1900HS,HA			1
61	SM6061802TP	SCREW M6 L=18				1
62	SS6110610TP	SCREW 11/64-40 L=6				3
63	SS2110920TP	SCREW 11/64-40 L=8.5				2
64	SM3061052TP	SCREW M6 L=10				1
65	SS6110610TP	SCREW 11/64-40 L=6				1
66	SS4110515SP	SCREW 11/64-40 L=5				1
67	SS6110420TP	SCREW 11/64-40 L=4.8				6
68	SS6151142TP	SCREW 15/64-28 L=10.5				1
69	SS6151220SP	SCREW 15/64-28 L=11.5				1
70	SS8080310TP	SCREW 1/8-44 L=2.8				2
71	WP0621016SD	WASHER 6.2X13X1				1
72	WP0621016SD	WASHER 6.2X13X1				1
73	14116404	FEED PLATE D	FOR LK-1900FS,FA(FOR JE)			1
74	14116800	FEED PLATE H	FOR LK-1900FS,FA(EXCEPT JE)			1
75	14110209	LENGTHWISE FEED SHAFT				1
76	14111504	CROSSFEED SENSOR SLIT				1
77	14111702	SENSOR INSTALLING BASE				1
78	14136402	LENGTHWISE FEED SENSOR SLIT				1
79	14111801	SENSOR INSTALLING BASE				1
80	26500108	CLOTH FEED SUPPORT PLATE				1
81	14110811	CLOTH FEED PLATE				1
82	14116107	FEED PLATE A	FOR LK-1900SS,SA			1

LUBRICATION COMPONENTS

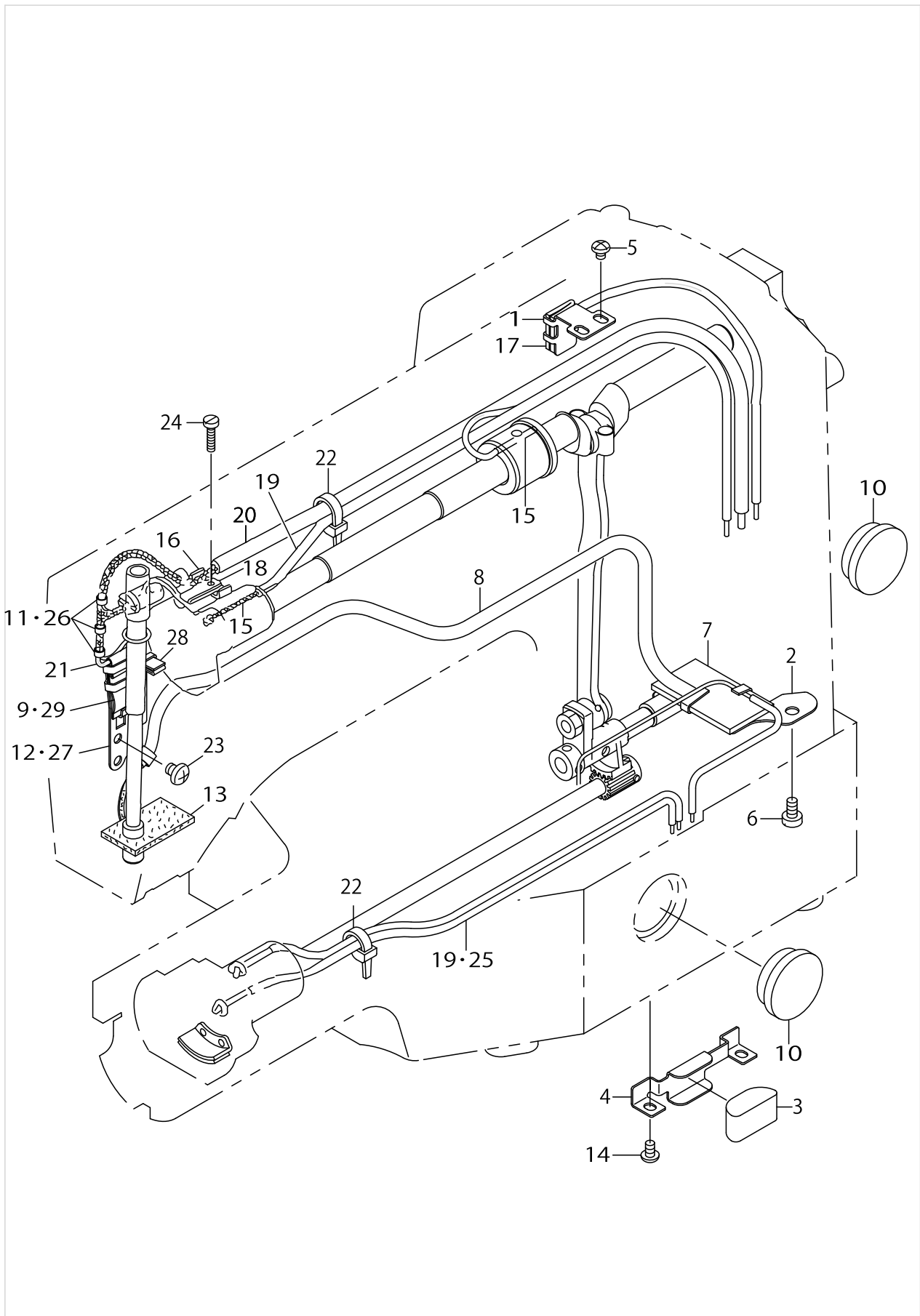

LUBRICATION COMPONENTS

No.	Parts No.	Parts name	Remarks	Level	Cons	Qty
1	14114102	OIL SHIELD				1
2	14114904	OIL SHIELD				1
3	14114300	OIL FELT				1
4	14114409	FELT PRESSER				1
5	SS4110515SP	SCREW 11/64-40 L=5				2
6	SS6120930SP	SCREW 3/16-28 L=9				1
7	B3509210D00	OIL FELT				1
8	13529003	ONCE THROUGH OIL FELT				0.56
9	B3509220000	OIL SPONGE	FOR LK-1900FS,MS,FA,MA, LK-1903,LK-1904			1
10	B3501210000	OIL GAUGE				2
11	26230706	OIL WICK PRESSER	FOR LK-1900FS,MS,FA,MA, LK-1903,LK-1904			3
12	B3506280000	OIL WICK PRESSER	FOR LK-1900FS,MS,FA,MA, LK-1903,LK-1904			1
13	14114607	FACE FELT				1
14	SS4110715SP	SCREW 11/64-40 L=7				2
15	CQ200000000	OIL WICK				3
16	B3508280000	BALANCE LUBRICATING PLATE				1
17	B3509280000	NEEDLE ROD CRANK LUBRICATING				1
18	B3518280000	BALANCE LUBRICATING	FOR LK-1900FS,MS,FA,MA, LK-1903,LK-1904			1
19	BP300000100	VINYL TUBE				0.7
20	BP600000000	VINYL PIPE				0.72
21	CQ252200000	OIL WICK				1.6
22	EA9500B0100	CABLE BAND				2
23	SS4110715SP	SCREW 11/64-40 L=7				2
24	SS6092120SP	SCREW 9/64-40 L=21.2				1
25	CQ202000000	OIL WICK				1.06
26	B1419026000	OIL WICK PRESSER	FOR LK-1900SS,HS,SA,HA, LK-1901,LK-1902			2
27	14114805	OIL WICK PRESSER	FOR LK-1900SS,HS,SA,HA, LK-1901,LK-1902			1
28	B3518280000	BALANCE LUBRICATING	FOR LK-1900SS,HS,SA,HA, LK-1901,LK-1902			1
29	B3509280000	NEEDLE ROD CRANK LUBRICATING	FOR LK-1900SS,HS,SA,HA, LK-1901,LK-1902			1

SENSOR & EXTENSION CABLE COMPONENTS

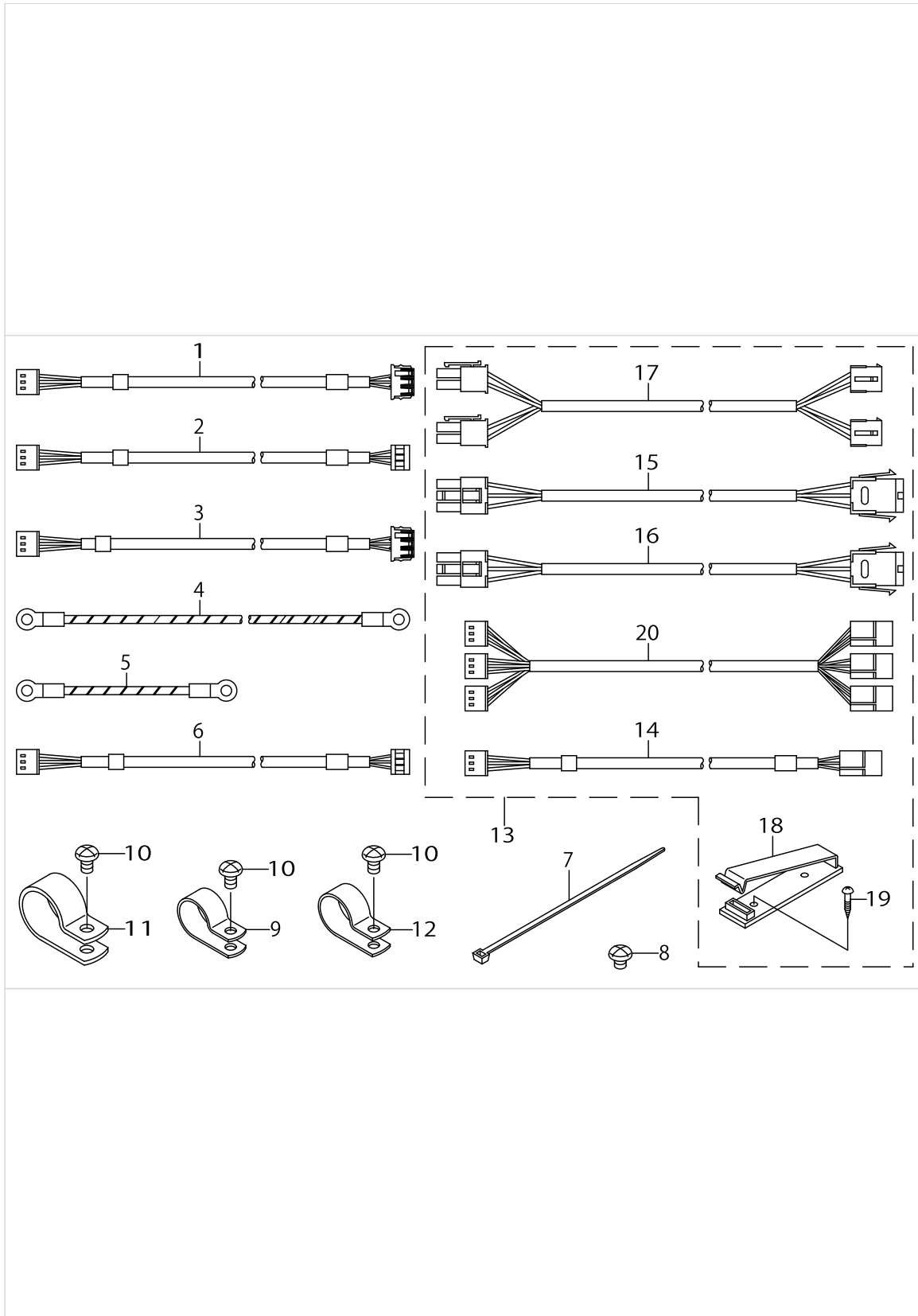

SENSOR & EXTENSION CABLE COMPONENTS

No.	Parts No.	Parts name	Remarks	Level	Cons	Qty
1	14115158	X SENSOR CABLE ASM.				1
2	14115257	Y SENSOR CABLE ASM.				1
3	14115356	MAIN SHAFT SENSOR CABLE ASM.				1
4	14115554	HEAD GROUND CABLE A ASM.				1
5	14115653	HEAD GROUND CABLE B ASM.				1
6	14115455	OUTER PRESSER SENSOR CABLE ASM				1
7	EA9500B0100	CABLE BAND				1
8	SS4110515SP	SCREW 11/64-40 L=5				3
9	HX00150000G	CABLE CLIP				1
10	SS4110715SP	SCREW 11/64-40 L=7				3
11	HX00150000L	CABLE CLIP				1
12	HX00150000H	CABLE CLIP				1
13	M85985900A0	EXTENSION CABLE COMPL. ASM.	FOR JUS,LK-1902			1
14	M90475900A0	SENSOR EXTENION CABLE ASM.		*		1
15	M90415900A0	EXTENION CABLE ASM.		*		1
16	M90425900A0	EXTENION CABLE ASM.		*		1
17	M90435900A0	SOLENOID EXTENION CABLE ASM.		*		1
18	M964051000A	CABLE CLIP		*		1
19	SK3382001SE	SCREW D=3.8 L=20		*		2
20	M90445900A0	SENSOR EXTENION CABLE ASM.		*		1

THREAD STAND COMPONENTS

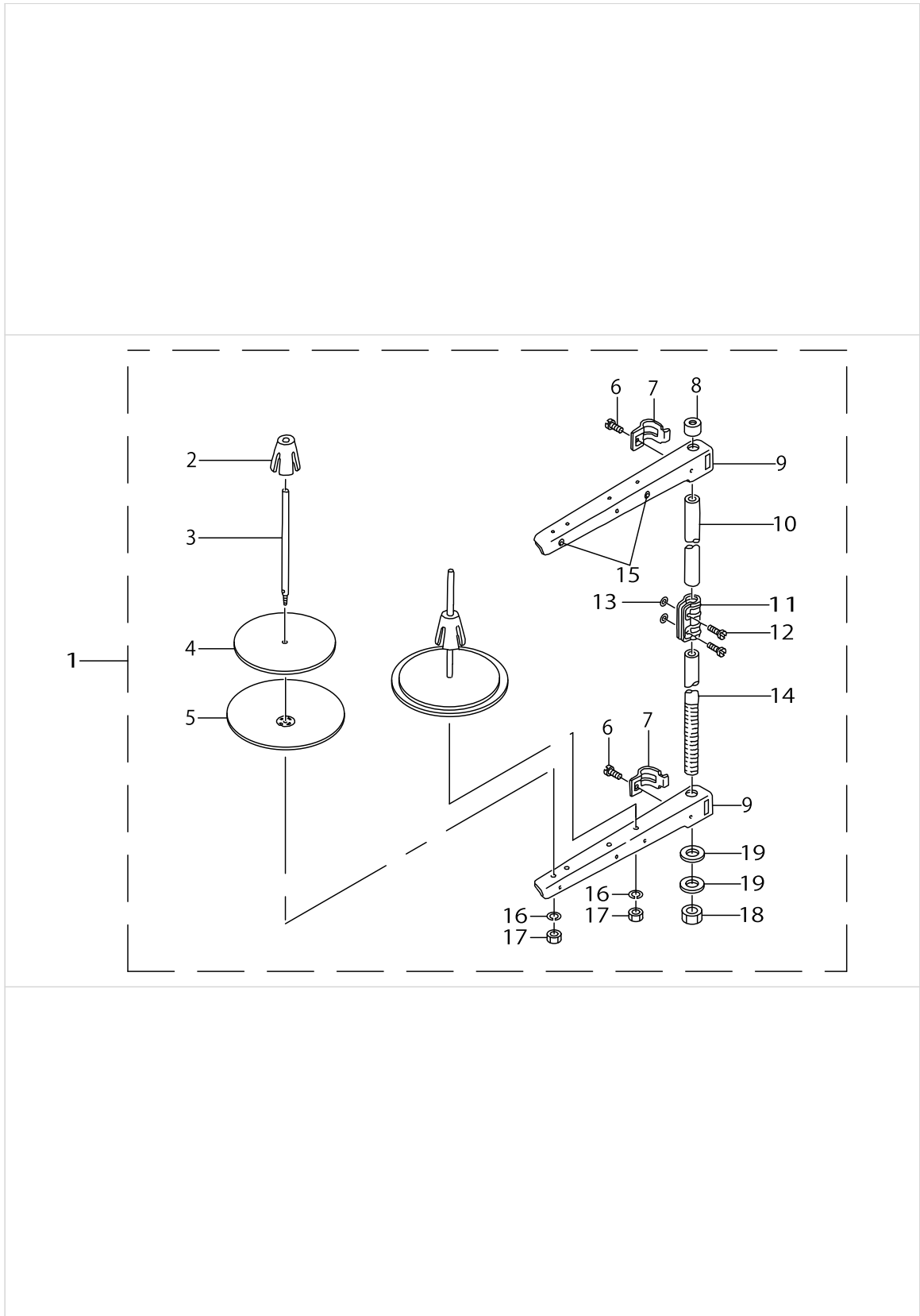

THREAD STAND COMPONENTS

No.	Parts No.	Parts name	Remarks	Level	Cons	Qty
1	22930358	THREAD STAND ASM.				1
2	22931109	SPOOL RETAINER		*		2
3	22931000	SPOOL PIN		*		2
4	22930903	SPOOL REST CUSHION		*		2
5	22930804	SPOOL REST		*		2
6	SM6061610SC	SCREW M6 L=16		*		2
7	22930705	THREAD GUIDE ARM JOINT		*		2
8	22931406	SPOOL REST ROD RUBBER CAP		*		1
9	22930507	SPOOL REST ARM		*		2
10	22930408	SPOOL REST ROD, UPPER		*		1
11	22931307	SPOOL REST ROD JOINT		*		1
12	SM4051405SE	SCREW M5 L=14		*		2
13	NM6050001SE	NUT M5		*		2
14	22930309	SPOOL REST ROD, LOWER		*		1
15	22931208	THREAD GUIDE		*		2
16	WS0510002KN	SPRING WASHER		*		2
17	NM6050001SE	NUT M5		*		2
18	NM6160511SE	NUT M16X1.5		*		1
19	WP1702600S0	WASHER 17X30X2.6		*		2

CONTROL BOX COMPONENTS

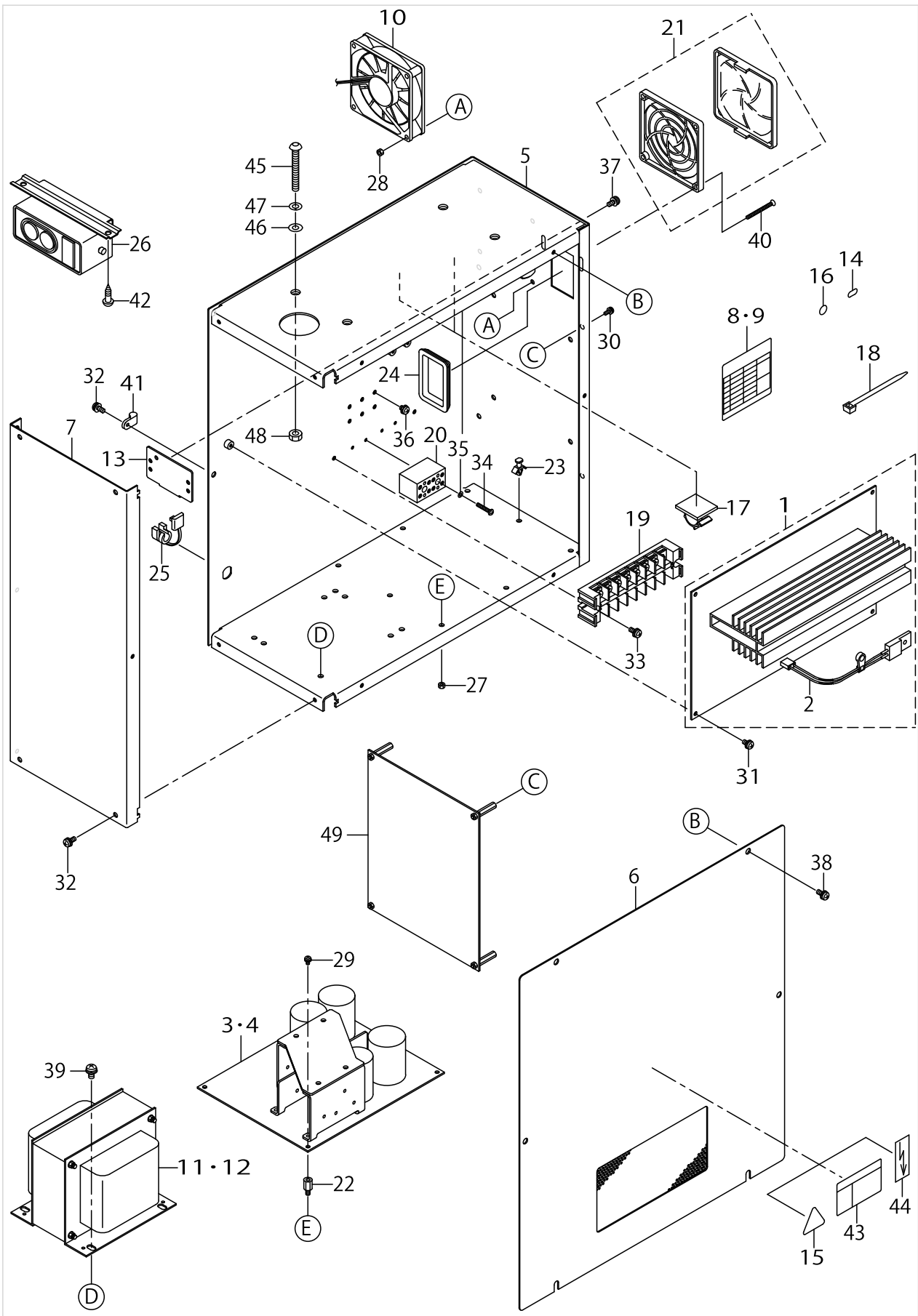

CONTROL BOX COMPONENTS

No.	Parts No.	Parts name	Remarks	Level	Cons	Qty
1	M8601590AA0	MAIN CIRCUIT BOARD ASM., A				1
2	M89105900A0	THERMOSTAT ASM.		*		1
3	M86045900A0	POWER CIRCUIT BOARD ASM.	FOR 100V-200V			1
4	M8604590AA0	POWER CIRCUIT BOARD ASM., A	FOR 380V			1
5	M1001590000	CONTROL BOX				1
6	M10025800A0	CONTROL BOX COVER ASM.				1
7	M1003590000	CONTROL BOX PANEL				1
8	M300359000A	SEAL A	FOR 100V-200V			1
9	M300258000B	SEAL B	FOR 380V			1
10	M85405900A0	FAN ASM.				1
11	M8901590AA0A	POWER TRANSFORMER A ASM.	FOR 100V-200V			1
12	M8901590BA0A	POWER TRANSFORMER B ASM.	FOR 380V			1
13	17845009	CORD FITTING PLATE				1
14	CM200100001	PE MARK LABEL	FOR 380V			1
15	CM300100001	LABEL	FOR 380V			1
16	E9567319000	EARTH MARK				1
17	E9609603000	STICKER (LARGE)				2
18	EA9500B0100	CABLE BAND				1
19	HK026650080	TERMINAL BASE 8P	FOR 100V-200V			1
20	HK054250040	TERMINAL BASE	FOR 380V			2
21	HM000860010	FAN FILTER				1
22	HX00056000B	SPACER				4
23	HX00147000C	SPACER				4
24	HX004070000	BUSH				1
25	HX004100000	BUSH				1
26	HA004250000	SWITCH	EXCEPT JE			1
27	NM3034000SF	FLANGE NUT				4
28	NM6030003SC	NUT M3				2
29	SL4030681SF	SCREW M3 L=6				4
30	SL4030891SC	SCREW M3X8				4
31	SL4040881SF	SCREW M4 L=8				4
32	SL4041091SC	SCREW M4 L=10				7
33	SL4041081SF	SCREW M4 L=10	FOR 100V-200V			2
34	SM4031851SR	SCREW	FOR 380V			4
35	WS0310702KS	SPRING WASHER	FOR 380V			4
36	SL4040681SC	COMBINATION SCREW M4 X 8				4
37	SL4041091SC	SCREW M4 L=10				2
38	SL4041091SC	SCREW M4 L=10				6
39	SL4051091SC	SCREW M5X0.8 L=10				4
40	SM1033501SC	SCREW M3X0.5 L=35				2
41	HX00123000B	CABLE CLIP				1
42	SK3482001SE	WOOD SCREW D=4.8 L=20	EXCEPT JE			2
43	CM300100101	DANGER LABEL (SMALL)	FOR 100V-200V(USE IN JAPAN)			1
44	G6705152U0A	LABEL	FOR 100V-200V(EXPORT)			1
45	SM3065052TC	SCREW				4
46	WP0651001SC	WASHER				4
47	WS0610002KN	SPRING WASHER 6.1X12.2X1.5				4

CONTROL BOX COMPONENTS

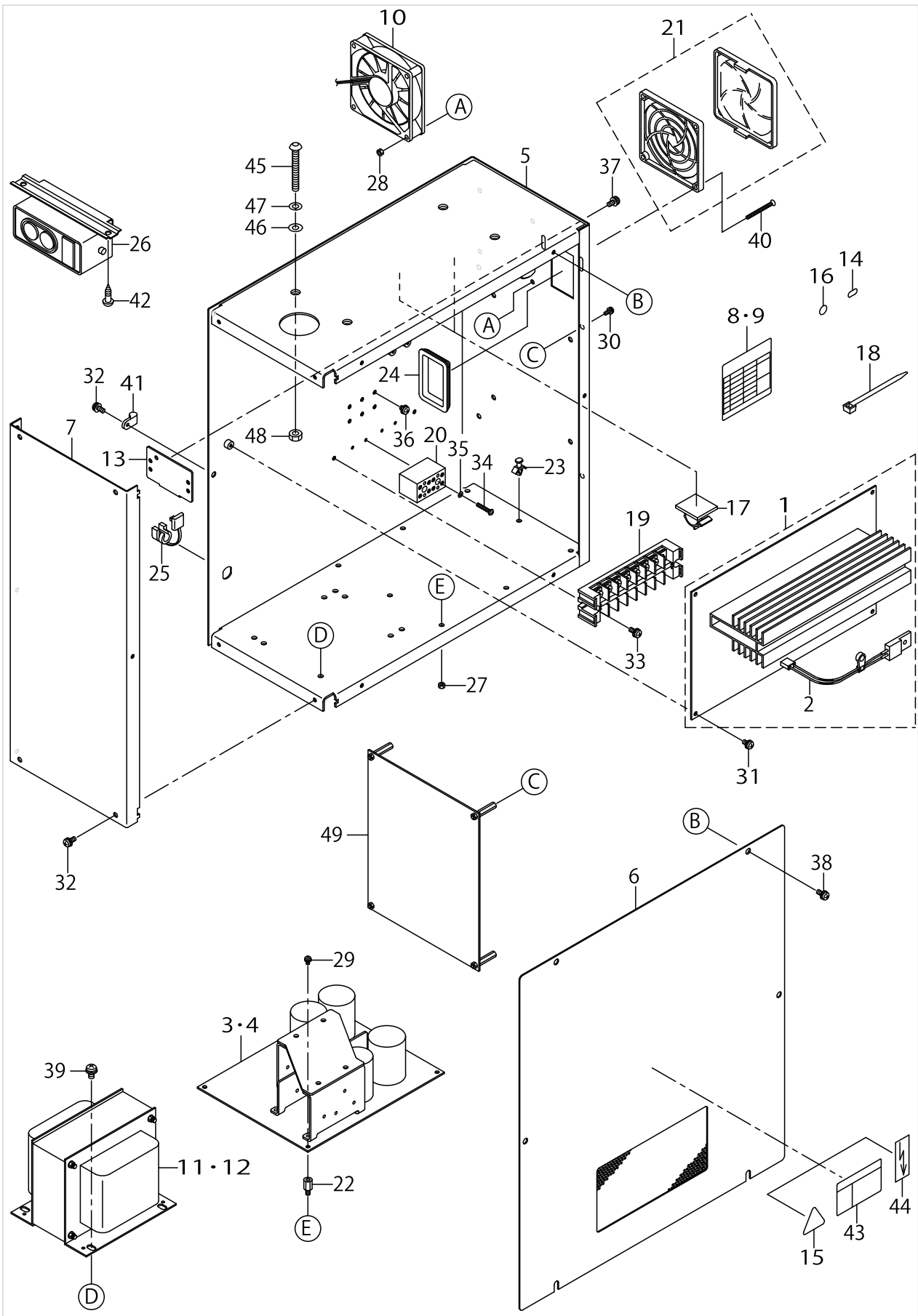

CONTROL BOX COMPONENTS

No.	Parts No.	Parts name	Remarks	Level	Cons	Qty
48	NM6060001SE	NUT M6				4
49	M8612590AA0	SERVO CIRCUIT BOARD A ASM.				1

OPERATION BOX & PEDAL COMPONENTS

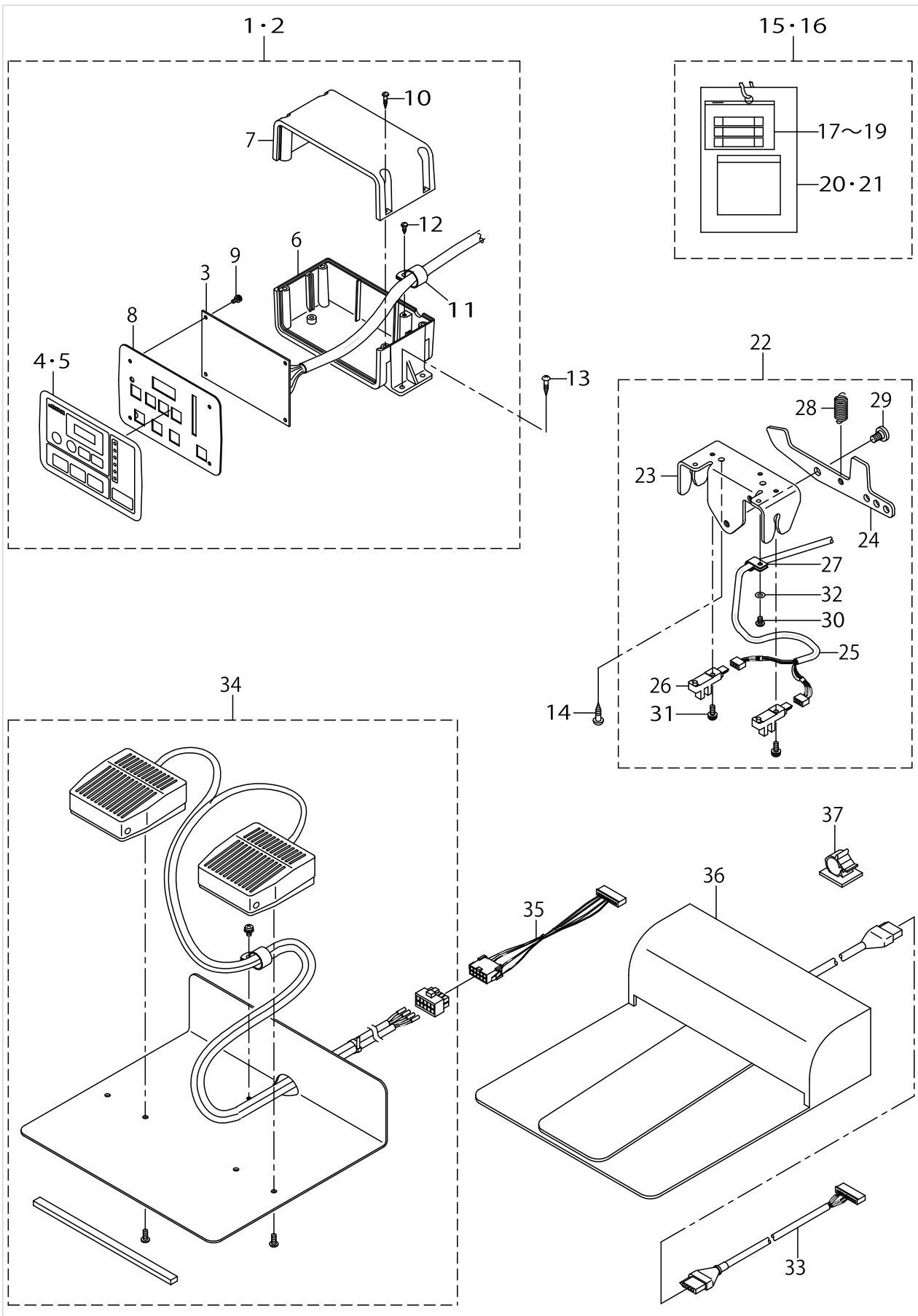

OPERATION BOX & PEDAL COMPONENTS

No.	Parts No.	Parts name	Remarks	Level	Cons	Qty
1	M8510590AA0	OPERATION BOX A ASM.	FOR USE IN JAPAN			1
2	M8510590BA0	OPERATION BOX B ASM.	FOR EXPORT			1
3	M86065900A0	OPERATION CIRCUIT BOARD ASM.		*		1
4	M300259000A	OPERATION PANEL SHEET(JAPAN)	FOR USE IN JAPAN	*		1
5	M300259000B	OPERATION PANEL SHEET(ENG)	FOR EXPORT	*		1
6	M1010590000	OPERATION BOX A		*		1
7	M1011590000	OPERATION BOX B		*		1
8	M1012590000	OPERATION PANEL PLATE		*		1
9	SL4030881SF	SCREW M3 L=8		*		4
10	ST40316110R	TAPPING SCREW D=3 L=16		*		4
11	EA9502B0500	CABLE CLIP		*		1
12	SV4031006SR	SCREW M3 L=10		*		1
13	SK3382001SE	SCREW D=3.8 L=20		*		4
14	SK3482001SE	WOOD SCREW D=4.8 L=20		*		2
15	M85995900A0	ACCESSORIES PART ASM.	FOR 100V-200V			1
16	M8599590AA0	ACCESSORIES PART A ASM.	FOR 380V			1
17	HF001301000	TIMING LAG FUSE		*		1
18	HF0041080P0	FUSE 8A		*		1
19	E8523304000	FUSE 10A		*		1
20	M300451100A	VOLTAGE INDICATION CARD,A	FOR 100V-200V	*		1
21	M3003580000	VOLTAGE INDICATION CARD,B	FOR 380V	*		1
22	M85205900A0	1-PEDAL ASM.				1
23	M1030590000	PEDAL SWITCH FRAME		*		1
24	M1031590000	PEDAL SWITCH LEVER		*		1
25	M90115900A0	PEDAL SWITCH CABLE ASM.		*		1
26	HD002230000	PHOTO SENSOR		*		2
27	HX001230000	CABLE CLIP		*		1
28	B2583210D00	SPRING		*		1
29	SD0800331TH	HINGE SCREW D=8 H=3.25		*		1
30	SM4040601SC	SCREW M4X0.7 L=6		*		1
31	SL4041291SC	SCREW M4 L=12		*		2
32	WP0430801SC	WASHER 4.3X9X0.8		*		1
33	M90135900A0	PK57 TRANSFER CABLE ASM.	OPTIONAL PARTS			1
34	M85205800A0	2-PEDAL ASM.	OPTIONAL PARTS			1
35	M90125900A0	PEDAL SWITCH CHANGE CABLE ASM.	OPTIONAL PARTS			1
36	GPK570010B0	PEDAL SWITCH ASM.	OPTIONAL PARTS			1
37	E9607603000	STICKER (SMALL)	OPTIONAL PARTS			2

WIRING DIAGRAM

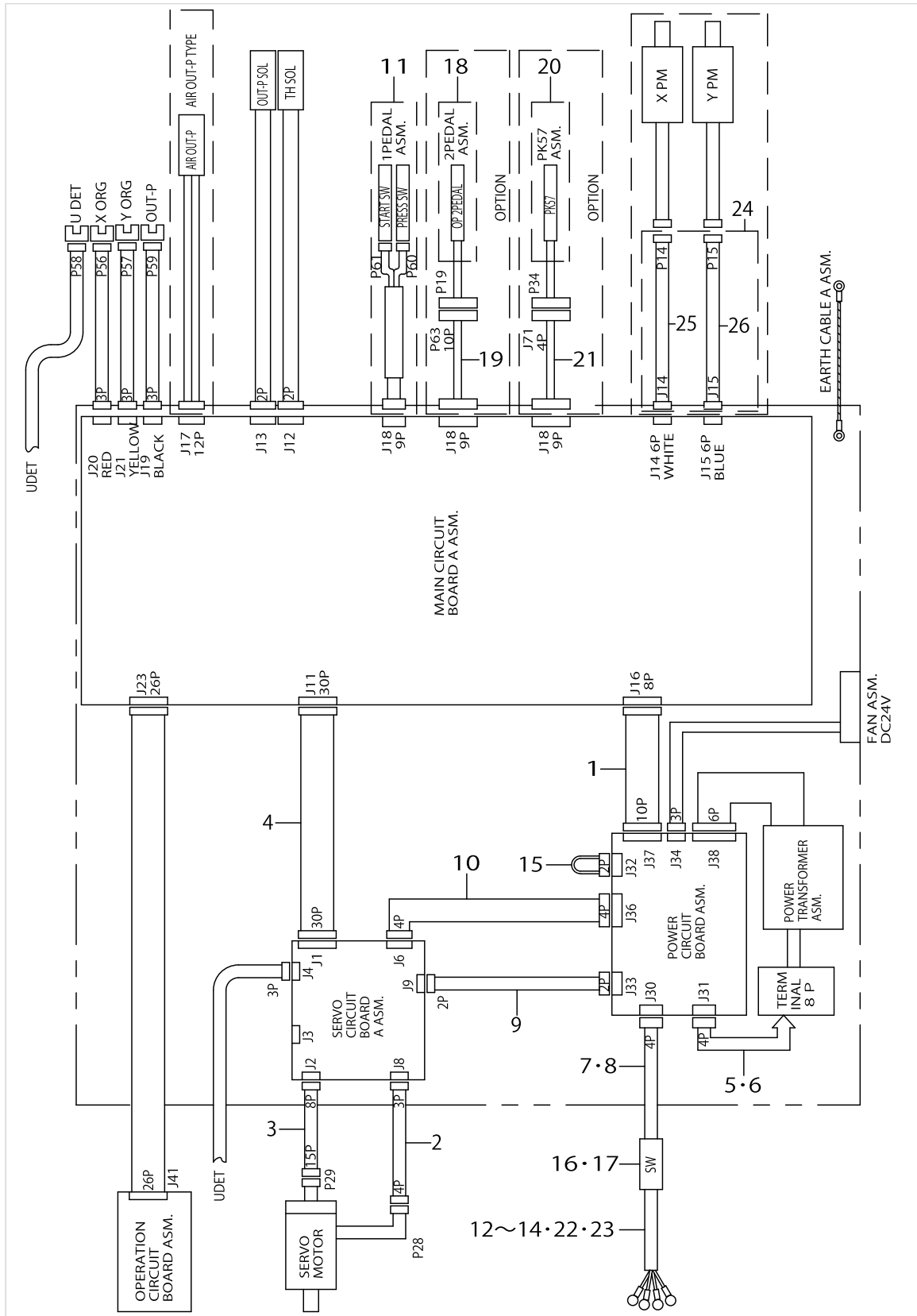

WIRING DIAGRAM

No.	Parts No.	Parts name	Remarks	Level	Cons	Qty
1	M90015900A0	MAIN POWER CORD ASM.				1
2	M90035900A0	SERVO MOTOR CABLE ASM.				1
3	M90045900A0	ENCODER CONNECTING CABLE ASM.				1
4	M90085800A0	SERVO SIGNAL CORD ASM.				1
5	M90205800A0	TRANSFORMER POWER CORD ASM.	FOR 100V-200V			1
6	M9020580AA0	TRANSFORMER POWER CORD ASM.,A	FOR 380V			1
7	M90225900A0	POWER CORD ASM.	FOR 100V-200V			1
8	M90235900A0	POWER CORD A ASM.	FOR 380V			1
9	M90025800A0	SERVO POWER CORD ASM.,B				1
10	M90315900A0	SERVO POWER CORD ASM.,A				1
11	M85205900A0	1-PEDAL ASM.				1
12	M90175800A0	POWER CABLE ASM.	FOR 100V-200V(3-PHASE), 380V(FOR EXPORT)			1
13	M90285800A0	POWER CABLE ASM.	FOR MC-590-ΔM			1
14	M90245800A0	POWER CABLE ASM.,100V	FOR 1-PHASE(FOR EXPORT)			1
15	M90215800A0	VOLTAGE TRANSFER CORD ASM.	FOR 100V			1
16	HA004250000	SWITCH	EXCEPT MC-590-ΔM			1
17	HA00303000A	SWITCH	FOR MC-590-ΔM			1
18	M85205800A0	2-PEDAL ASM.	OPTIONAL PARTS			1
19	M90125900A0	PEDAL SWITCH CHANGE CABLE ASM.	OPTIONAL PARTS			1
20	GPK570010B0	PEDAL SWITCH ASM.	OPTIONAL PARTS			1
21	M90135900A0	PK57 TRANSFER CABLE ASM.	OPTIONAL PARTS			1
22	M90355800A0	POWER SOURCE CORD ASM.	FOR 100V(FOR USE IN JAPAN)			1
23	M90345800A0	GROUND CORD ASM.	FOR 100V(FOR USE IN JAPAN)			1
24	M85975900A0	CABLE WHOLE ASM.				1
25	M90515900A0	CABLE ASM.		*		1
26	M90525900A0	CABLE ASM.		*		1

ACCESSORIE PART COMPONENTS

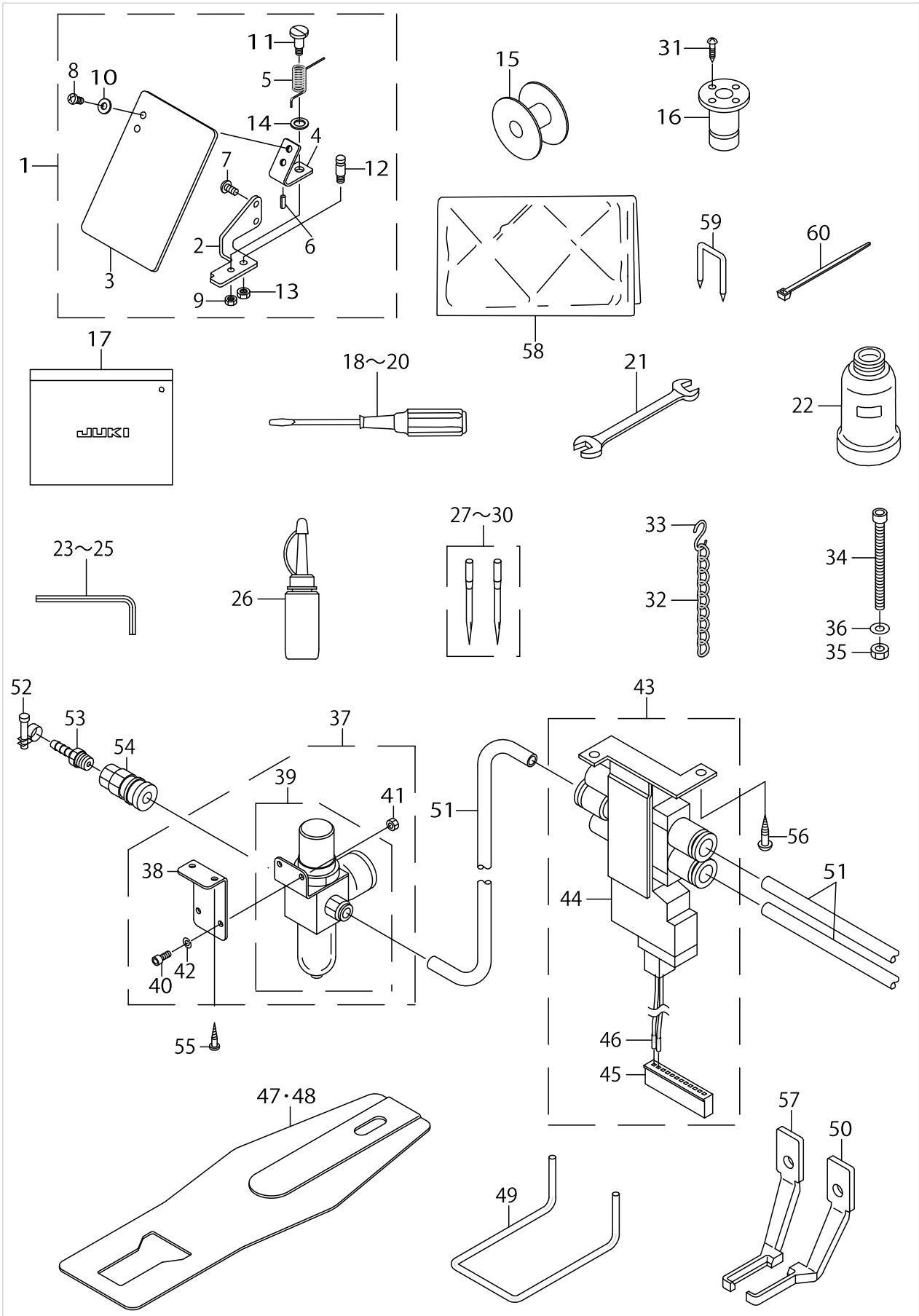

ACCESSORIE PART COMPONENTS

No.	Parts No.	Parts name	Remarks	Level	Cons	Qty
1	13551254	SAFETY PLATE ASM.				1
2	13551205	SAFETY PLATE INSTALLING BASE		*		1
3	B3120372000	SAFETY PLATE		*		1
4	B3121372000	SAFETY PLATE INSTALLING PLATE		*		1
5	13943204	SAFETY PLATE RETURN SPRING		*		1
6	PS0200062KH	SPRING PIN 2X6		*		1
7	SS4110715SP	SCREW 11/64-40 L=7		*		2
8	SS4110715SP	SCREW 11/64-40 L=7		*		2
9	NS6110310SP	NUT 11/64-40		*		1
10	WP0450801SD	WASHER 4.5X10X0.8		*		2
11	SD0601021SP	HINGE SCREW D=6 H=10.2		*		1
12	B1506352000	TENSION SPRING RACK B		*		1
13	NS6120310SP	NUT 3/16-28		*		1
14	WP0740516SP	WASHER 7.4X11.8X0.5		*		1
15	13812102	BOBBIN				1
16	B8202205000	OIL MANAGEMENT				1
17	B9101552000	ACCESSORY BOX				1
18	B9109555000	SCREW DRIVER, LARGE				1
19	B9110012000	SCREW DRIVER, MIDDLE				1
20	B9111012000	SCREW DRIVER, SMALL				1
21	B9113012000	WRENCH (9X10)				1
22	B9121012000	OIL CAN				1
23	B9140372000	HEXAGONAL WRENCH, SMALL				1
24	B9141372000	HEXAGONAL WRENCH, LARGE				1
25	GCT02906000	HEXAGONAL SPANNER				1
26	B91212200A0	OILER (CONTAINING NO.2 OIL)				1
27	MDP500B1402	NEEDLE DPX5#14-2	FOR LK-1900SS,SA(USE IN JAPAN)			1
28	MDP500B1602	NEEDLE DPX5#16-2	FOR LK-1900SS,SA(EXPORT)			1
29	MDP170B1902	NEEDLE DPX17#19-2	FOR LK-1900HS,HA			1
30	MDP500B1102	DPX5#11-2	FOR LK-1900FS,MS,FA,MA			1
31	SK3311601SE	WOOD SCREW D=3.1 L=16				4
32	B8103980000	CHAIN				1
33	B8133019000	S SHAPED HOOK				2
34	SM6067552TP	HEXAGONAL-HOLE BOLT M6 L=75				1
35	NM6060001SC	NUT M6				1
36	WP0651646SC	WASHER				1
37	14106553	AIR REGULATOR ASM.	FOR LK-1900SA,HA,FA,MA			1
38	13860408	REGULATOR BRACKET		*		1
39	14106561	AIR REGULATOR A ASM.		*		1
40	SM6051202TP	SCREW M5X0.8 L=12		*		2
41	NM6050001SP	NUT M5		*		2
42	WS0510002KN	SPRING WASHER		*		2
43	14106652	SOLENOID VALVE ASM.	FOR LK-1900SA,HA,FA,MA			1
44	14106603	PRESSER LIFTER SOLENOID VALVE		*		1
45	HK016510120	HOUSING 12P		*		1
46	HK016540000	RECEPTABLE CONTACT		*		2

ACCESSORIE PART COMPONENTS

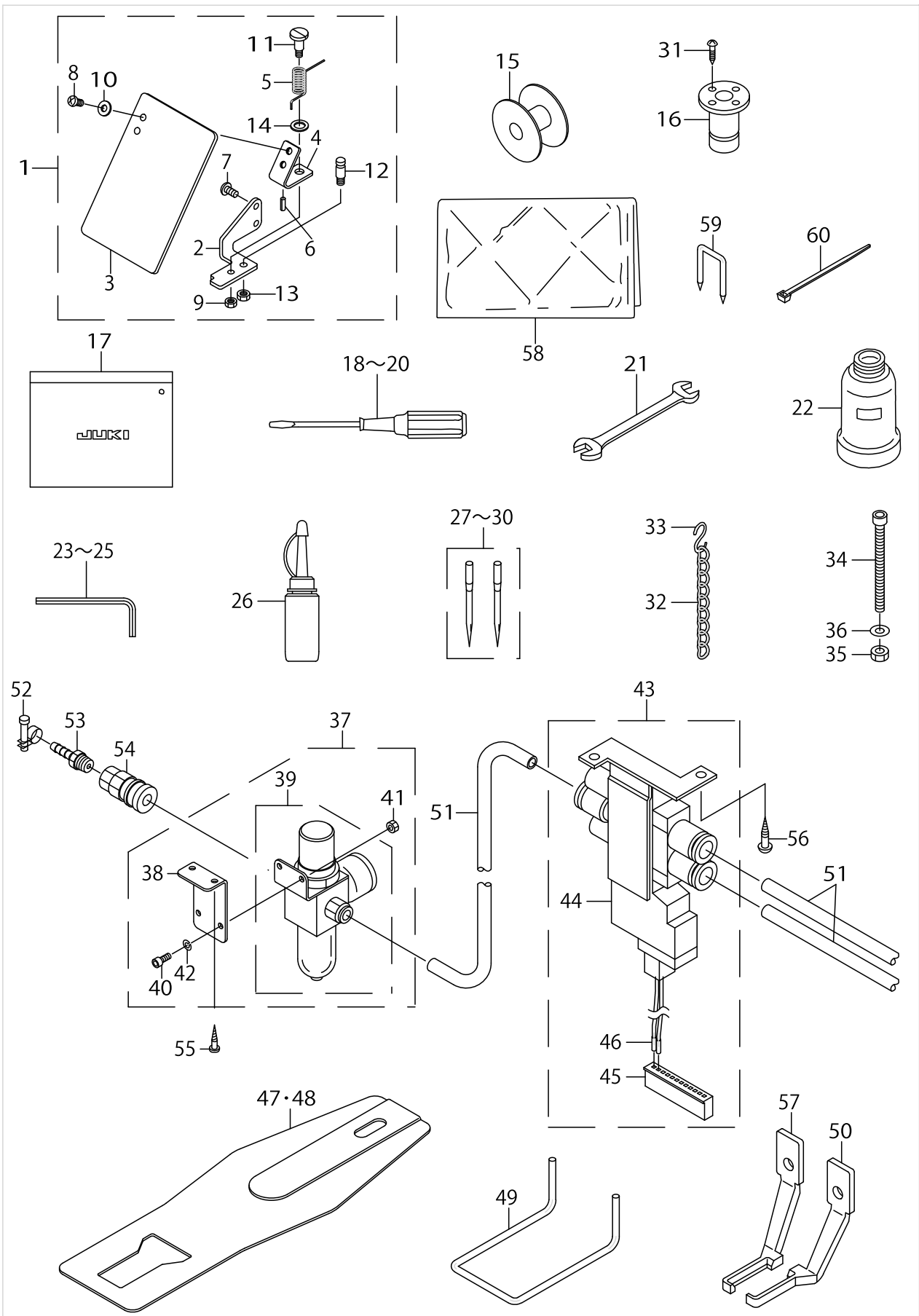

ACCESSORIE PART COMPONENTS

No.	Parts No.	Parts name	Remarks	Level	Cons	Qty
47	14116909	FEED PLATE I	FOR LK-1900FS,FA (EXCEPT JE & USE IN JAPAN)			1
48	14116503	FEED PLATE E	FOR LK-1900FS,FA (FOR JE)			1
49	13573407	FINGER GUARD	FOR LK-1900FS,FA(EXPORT)			1
50	13572003	CLOTH PRESSER FOOT (LEFT)	FOR LK-1900FS,FA(EXPORT)			1
51	BT0600401EB	TUBE	FOR LK-1900SA,HA,FA,MA			2
52	PB000010000	HOSE BAND	FOR LK-1900SA,HA,FA,MA			1
53	PJ032526001	HOSE NIPPLE	FOR LK-1900SA,HA,FA,MA			1
54	PJ309005201	PLUG	FOR LK-1900SA,HA,FA,MA			1
55	SK3482001SE	WOOD SCREW D=4.8 L=20	FOR LK-1900SA,HA,FA,MA			2
56	SK3311601SE	WOOD SCREW D=3.1 L=16	FOR LK-1900SA,HA,FA,MA			2
57	13571906	CLOTH PRESSER FOOT (RIGHT)	FOR LK-1900FS,FA(EXPORT)			1
58	26234005	VINYL COVER	EXCEPT USE IN JAPAN			1
59	MAO11532000	CORD STAPLE				7
60	EA9500B0200	CABLE BAND 150				2

OPTION COMPONENTS(1)

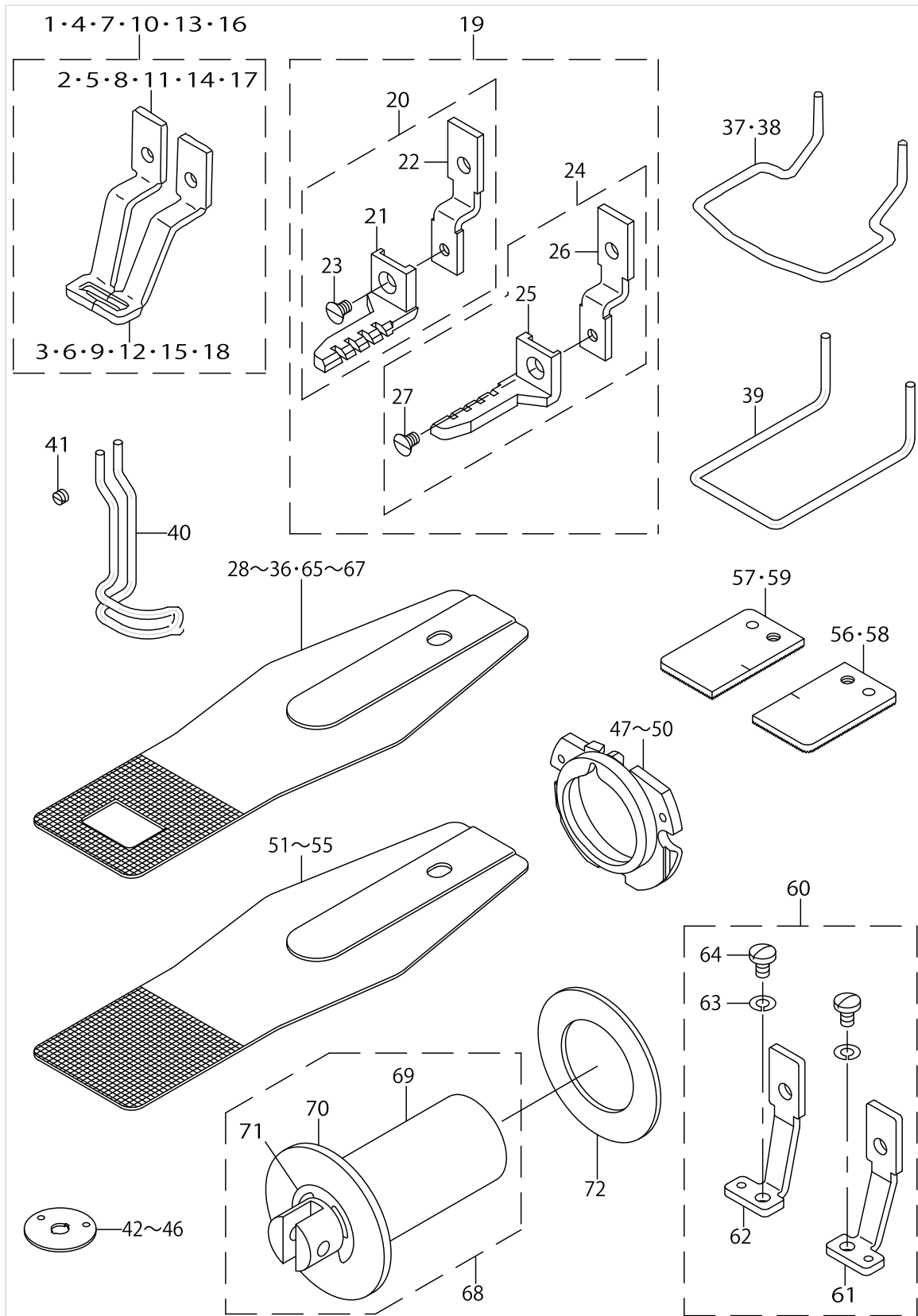

OPTION COMPONENTS(1)

No.	Parts No.	Parts name	Remarks	Level	Cons	Qty
1	13518659	WORK CLAMP FOOT ASM.				1
2	13518600	WORK CLAMP FOOT, RIGHT		*		1
3	13518709	WORK CLAMP FOOT, LEFT		*		1
4	13548557	WORK CLAMP FOOT ASM.				1
5	13548508	WORK CLAMP FOOT. RIGHT		*		1
6	13548607	WORK CLAMP FOOT. LEFT		*		1
7	13548151	CLOTH PRESSER FOOT ASM.				1
8	13548102	WORK CLAMR FOOT. RIGHT		*		1
9	13548201	WORK CLAMR FOOT LEFT		*		1
10	13542451	WORK CLAMP FOOT ASM.				1
11	13542402	WORK CLAMP FOOT, RIGHT		*		1
12	13542501	WORK CLAMP FOOT, LEFT		*		1
13	13542964	PRESSER ASM.				1
14	13542915	WORK CLAMP FOOT, RIGHT		*		1
15	13543012	WORK CLAMP FOOT, LEFT		*		1
16	13571955	WORK CLAMP FOOT ASM.				1
17	13571906	CLOTH PRESSER FOOT (RIGHT)		*		1
18	13572003	CLOTH PRESSER FOOT (LEFT)		*		1
19	13561360	WORK CLAMP FOOT ASM.				1
20	13561352	WORK CLAMP FOOT ASM.,RIGHT		*		1
21	13561303	CLOTH PRESSER FOOT (RIGHT)		*		1
22	13562509	PRESSER FOOT SLIDING PLATE (R)		*		1
23	SS1110640TP	SCREW 11/64-40 L= 5.5		*		1
24	13561451	WORK CLAMP FOOT ASM.,LEFT		*		1
25	13561402	CLOTH PRESSER FOOT (LEFT)		*		1
26	13562608	PRESSER FOOT SLIDING PLATE (L)		*		1
27	SS1110640TP	SCREW 11/64-40 L= 5.5		*		1
28	14116107	FEED PLATE A				1
29	14116404	FEED PLATE D				1
30	14116305	FEED PLATE C				1
31	13548003	FEED PLATE				1
32	13554506	FEED PLATE				1
33	14116602	FEED PLATE F				1
34	14116206	FEED PLATE B				1
35	14116503	FEED PLATE E				1
36	14116701	FEED PLATE G				1
37	26224204	FINGER GUARD				1
38	13548300	FINGER GUARD				1
39	13573407	FINGER GUARD				1
40	14120000	FINGER GUARD				1
41	SS8110310SP	SCREW 11/64-40 L= 2.8				1
42	B2426280000	NEEDLE HOLE GUIDE				1
43	B242628000B	NEEDLE HOLE GUIDE B				1
44	14109607	NEEDLE HOLE GUIDE				1
45	D2426282C00	NEEDLE HOLE GUIDE				1
46	D2426MMCK00	NEEDLE HOLE GUIDE				1
47	14103253	INNER HOOK PRESSER ASM., A				1

OPTION COMPONENTS(1)

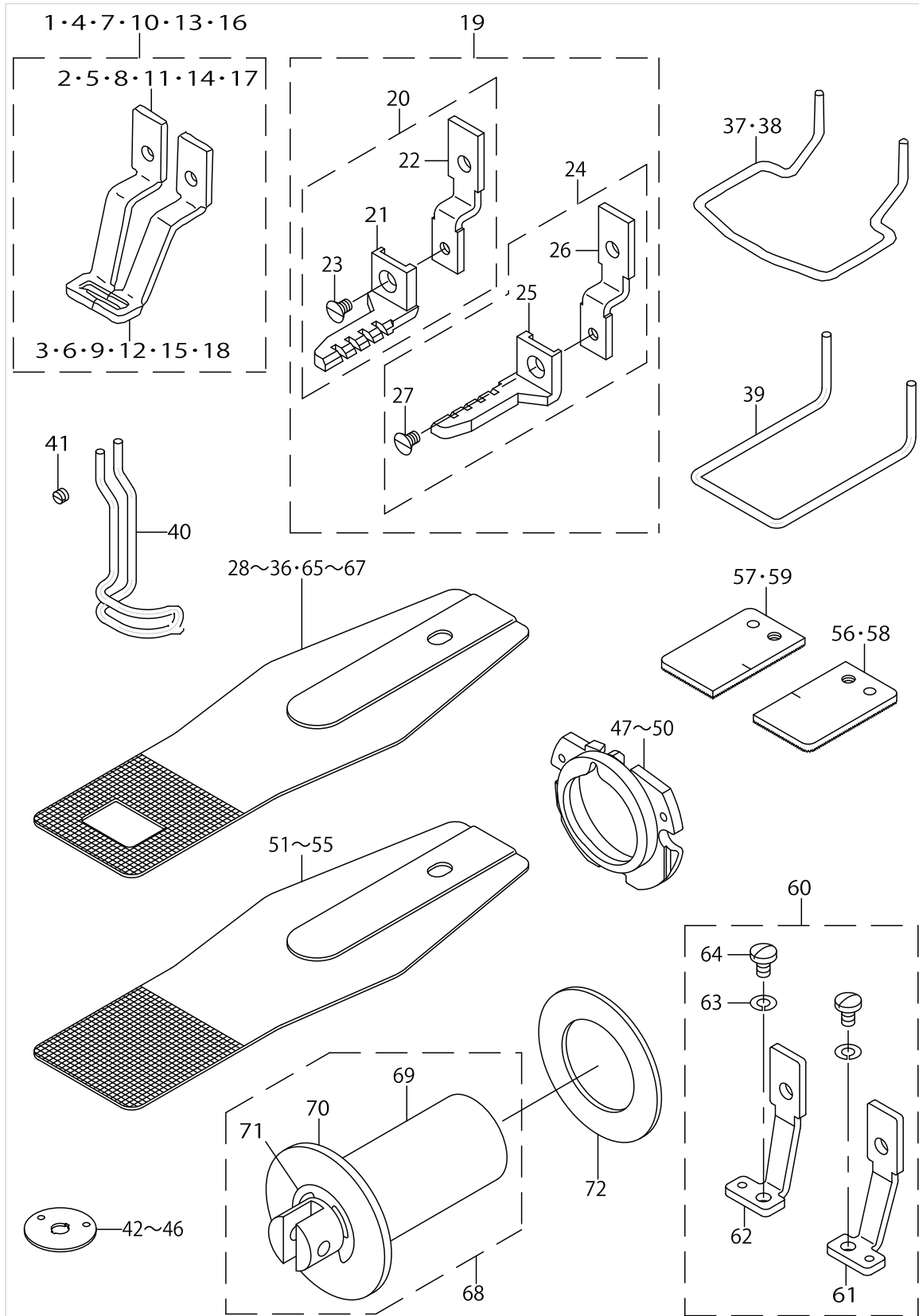

OPTION COMPONENTS(1)

No.	Parts No.	Parts name	Remarks	Level	Cons	Qty
48	14103352	INNER HOOK PRESSER ASM., B				1
49	14103659	SHUTTLE RACE RING ASM.,C				1
50	B1817210DAD	SHUTTLE RACE RING ASM.,D				1
51	14120109	FEED PLATE BLANK A				1
52	14120208	FEED PLATE BLANK B				1
53	14120505	FEED PLATE BLANK C				1
54	14120307	FEED PLATE BLANK D				1
55	14120406	FEED PLATE BLANK E				1
56	14121701	CLOTH PRESSER BLANK,R(SURFACE)				1
57	14121800	CLOTH PRESSER BLANK,L(SURFACE)				1
58	14121909	CLOTH PRESSER BLANK,RIGHT				1
59	14122006	CLOTH PRESSER BLANK,LEFT				1
60	14121263	WORK CLAMP FOOT ASM.				1
61	14121255	WORK CLAMP FOOT ASM.,RIGHT		*		1
62	14121354	WORK CLAMP FOOT ASM.,LEFT		*		1
63	WS0451040KP	SPRING WASHER 4.5X8.5X1		*		2
64	SS7110710SP	SCREW 11/64-40 L=7		*		2
65	14116800	FEED PLATE H				1
66	14116909	FEED PLATE I				1
67	13554803	FEED PLATE				1
68	14107155	SOLENOIDE PLUNGER ASM.				1
69	14107106	SOLENOIDE PLUNGER		*		1
70	14107205	RUBBER PRESSER		*		1
71	RE1500000K0	E-SHAPED SNAP RING		*		1
72	14107304	PRESSER RUBBER				1

OPTION COMPONENTS(2)(FOR LK-1900,1901,1902)

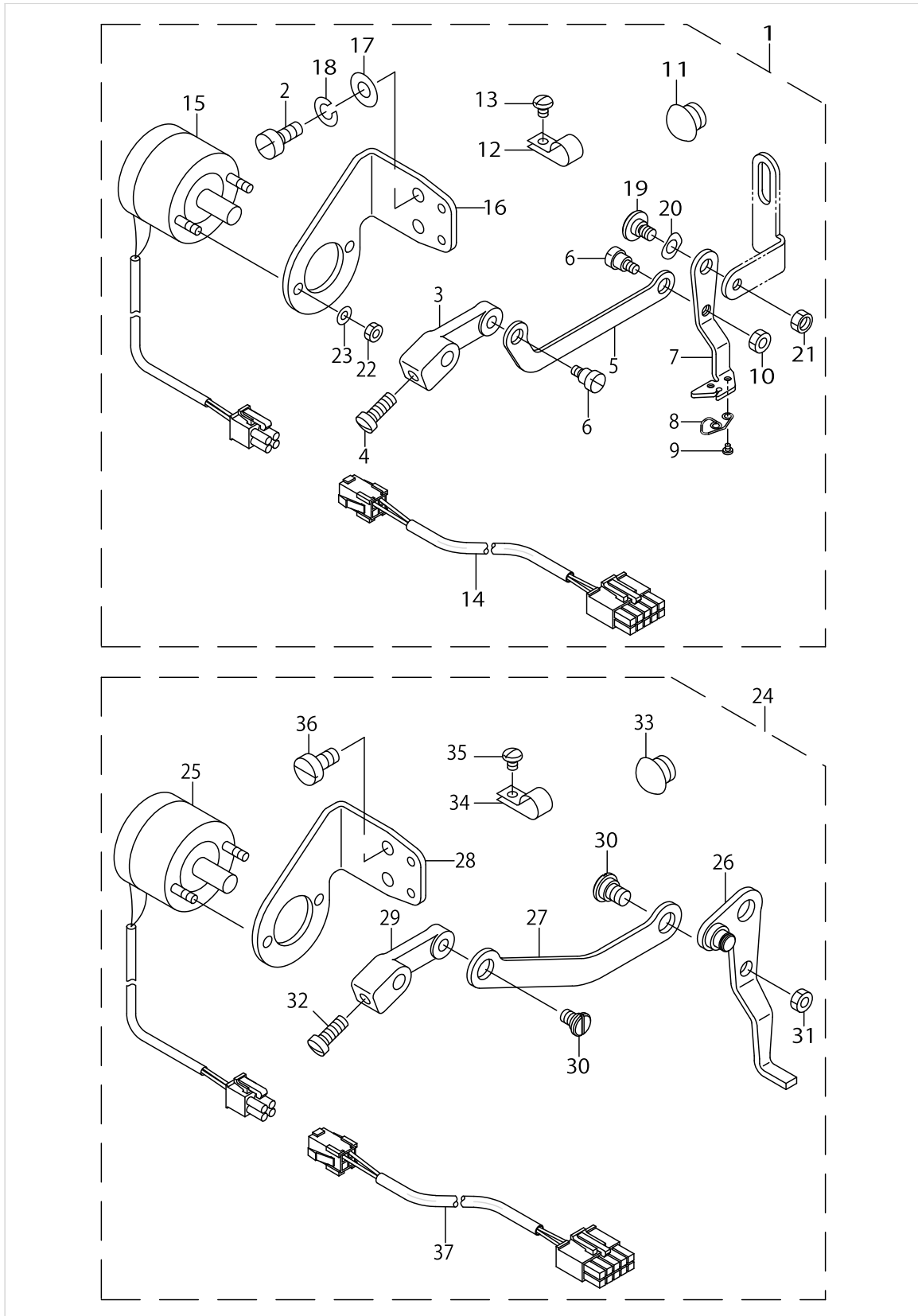

OPTION COMPONENTS(2)(FOR LK-1900,1901,1902)

No.	Parts No.	Parts name	Remarks	Level	Cons	Qty
1	14122550	MAGNET WIPER ASM.				1
2	SS6111010TP	SCREW 11/64-40 L= 9.5		*		2
3	B210220500A	WIPER ARM		*		1
4	SS7111120SP	SCREW 11/64-40 L=10.5		*		1
5	14147607	WIPER LINK		*		1
6	SD0600181TP	HINGE SCREW		*		2
7	40009859	WIPER		*		1
8	40009860	WIPER THREAD CATCH SPRING		*		1
9	SS7060310SP	SCREW 3/32-56 L=3		*		2
10	NS6110310SP	NUT 11/64-40		*		1
11	TA1250705R0	RUBBER PLUG		*		1
12	HX00123000C	CABLE CLIP		*		3
13	SS4110615SP	SCREW 11/64-40 L=6		*		3
14	14142251	SOLENOID RELAY CABLE ASM.		*		1
15	14147755	SOLENOID FOR WIPER ASM.		*		1
16	13864509	SOLENOID FITTING PLATE		*		1
17	WP0450801SD	WASHER 4.5X10X0.8		*		2
18	WS0451040KP	SPRING WASHER 4.5X8.5X1		*		2
19	SD0640261SP	HINGE SCREW D=3.65 H=2.6		*		1
20	WZ0640200KP	WAVE WASHER		*		1
21	NS6120310SP	NUT 3/16-28		*		1
22	NM6040003SC	NUT M4		*		2
23	WS0410002KS	SPRING WASHER M4		*		2
24	14122659	MAGNET WIPER ASM.				1
25	14147755	SOLENOID FOR WIPER ASM.		*		1
26	13864350	WIPER ASM.		*		1
27	13864400	WIPER LINK		*		1
28	13864509	SOLENOID FITTING PLATE		*		1
29	B210220500A	WIPER ARM		*		1
30	SD0600181TP	HINGE SCREW		*		2
31	NS6110310SP	NUT 11/64-40		*		1
32	SS7111120TP	SCREW		*		1
33	TA1250705R0	RUBBER PLUG		*		1
34	HX00123000C	CABLE CLIP		*		3
35	SS4110615SP	SCREW 11/64-40 L=6		*		3
36	SS6110810TP	SCREW 11/64-40 L=8		*		2
37	14142251	SOLENOID RELAY CABLE ASM.		*		1

TABLE COMPONENTS

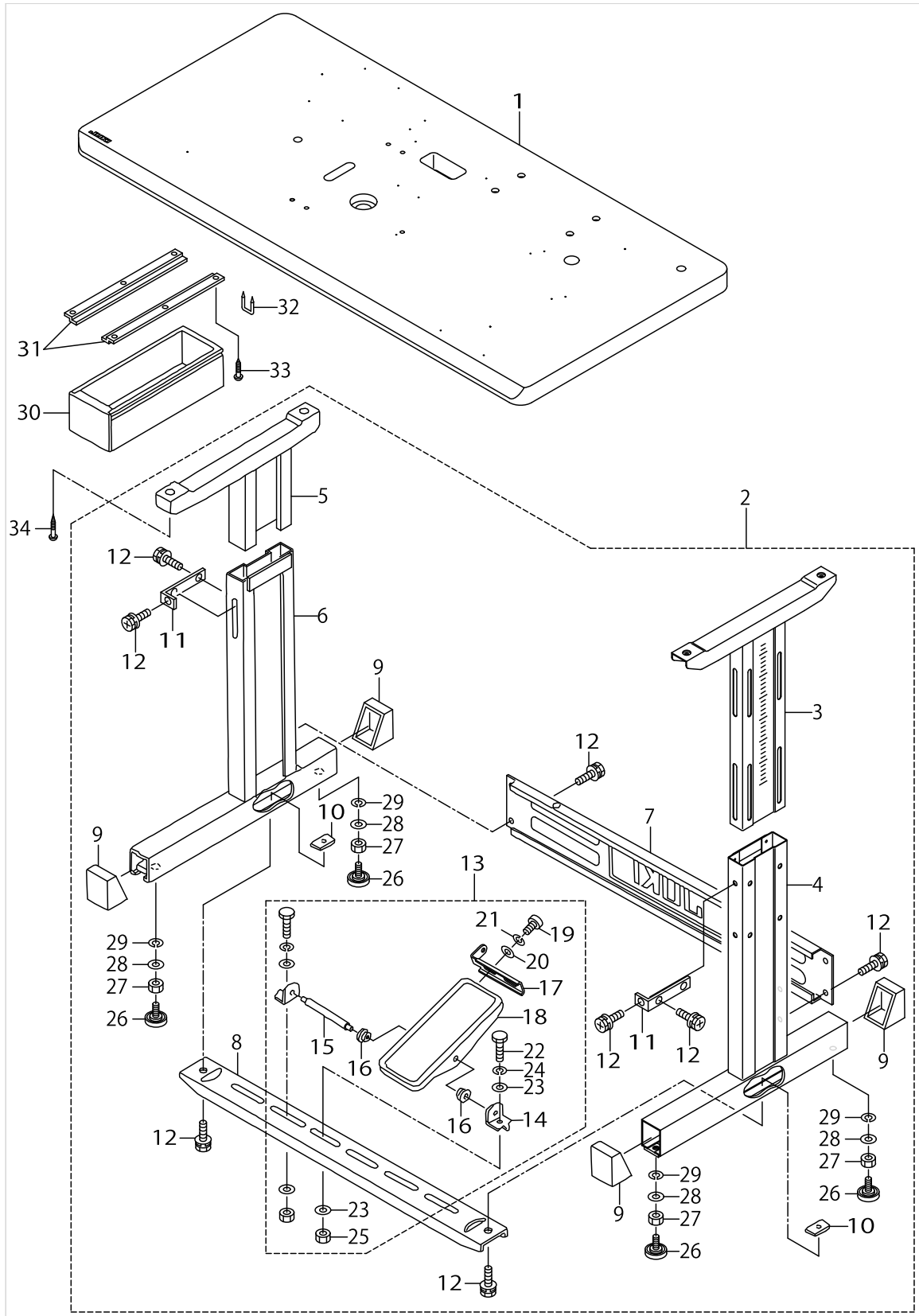
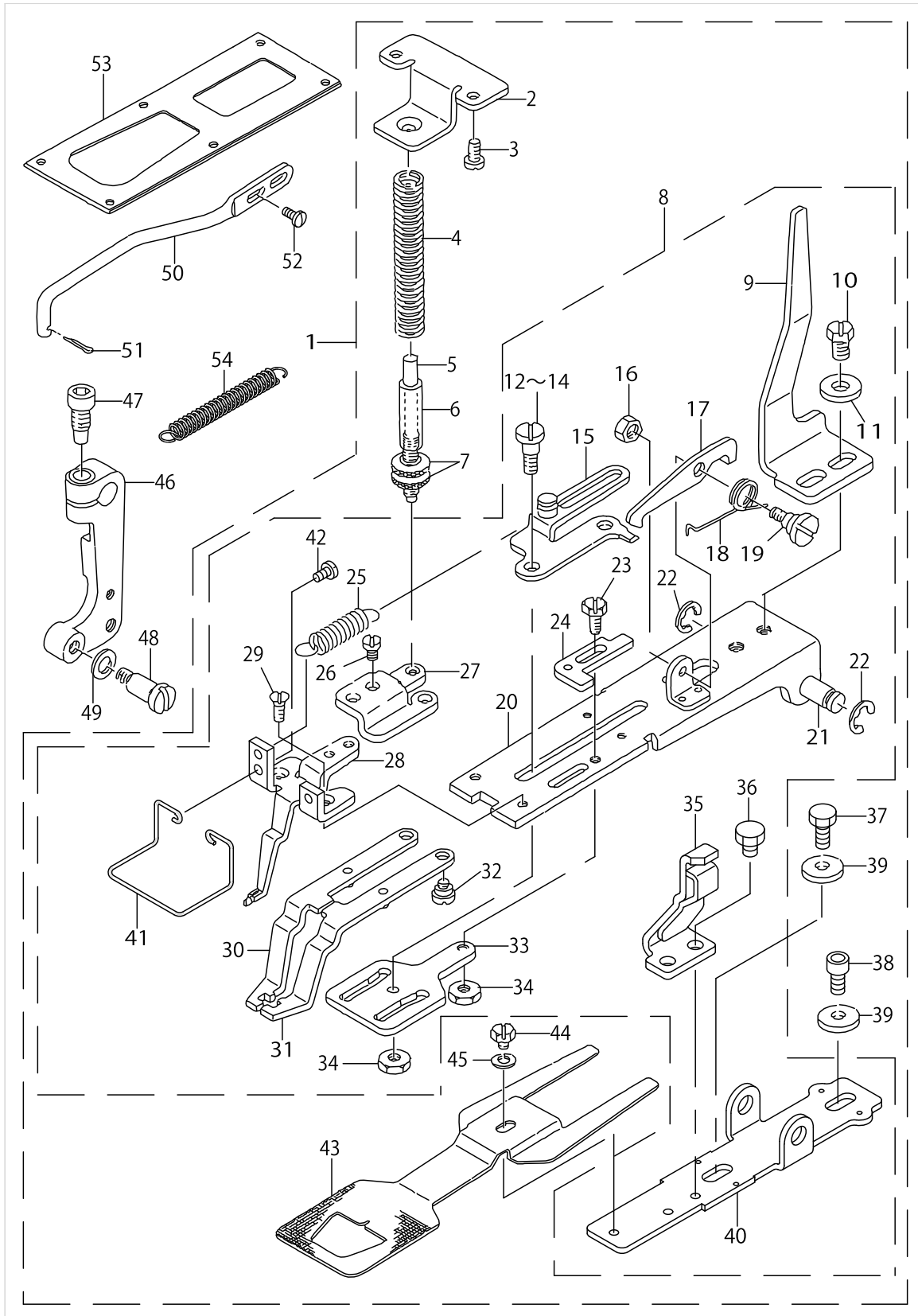

TABLE COMPONENTS

No.	Parts No.	Parts name	Remarks	Level	Cons	Qty
1	14117519	UPRIGHT TABLE				1
2	14118053	T-STAND COMPL.				1
3	14118152	UPPER STAND ASM.,RIGHT		*		1
4	14118251	STAND ASM.,RIGHT		*		1
5	B8101210AAB	UPPER STAND ASM.		*		1
6	B8105210AAA	STAND ASM.		*		1
7	11158300	STAND SIDE SUPPORT		*		1
8	11158409	STAND SIDE SUPPORT		*		1
9	11158607	RUBBER CAP		*		4
10	17007402	NUT		*		2
11	11158516	UPPER STAND PLATE		*		2
12	SL9082091SE	WASHER HEXAGONAL BOLT		*		12
13	13817754	Z-STAND PEDAL ASM.		*		1
14	11159001	PEDAL SHAFT BRACKET		*		2
15	B8153771000	PEDAL CONNECTING ROD		*		1
16	D8113555B00	PEDAL BUSHING		*		2
17	GPF06080000	PEDAL ADJUSTING PLATE		*		1
18	GPF060600A0	PEDAL ASM.		*		1
19	SM9061203SE	SCREW M6 L=12		*		2
20	WP0671016SE	WASHER 6.7X13X1		*		2
21	WS0621210KR	SPRING WASHER 6.2X11.4X1.2		*		2
22	SM9082023SE	SCREW M8 L=20		*		2
23	WP0871602SE	WASHER 8.7X18X1.6		*		4
24	WS0861410KR	SPRING WASHER 8.6X15X1.4		*		2
25	NM6080721SE	NUT M8		*		2
26	B81085550A0	ADJUSTING SCREW ASM. WITH CAP		*		4
27	NM6120001SE	NUT M12		*		4
28	WP1302501SE	WASHER M12		*		4
29	WS1253010KN	SPRING WASHER 12.5X21.5X3		*		4
30	11155108	DRAWER				1
31	11155207	DRAWER SUPPORT				2
32	D8204555D00	DRAWER STOPPER				1
33	SK3311601SE	WOOD SCREW D=3.1 L=16				6
34	SK3513201SE	WOOD SCREW D=5.1 L=32				4

LK-1901S△:WORK CLAMP MECHANISM COMPONENTS



LK-1901S△:WORK CLAMP MECHANISM COMPONENTS

No.	Parts No.	Parts name	Remarks	Level	Cons	Qty
1	14140263	PICK-UP DEVICE				1
2	13541602	WORK CLAMP FOOT SPRING HOLDER		*		1
3	SS7110840SP	SCREW 11/64-40 L=7.8		*		2
4	D2529232D00	PRESSER SPRING		*		1
5	D2528232D00	SHAFT		*		1
6	D2527232D00	SLEEVE		*		1
7	B3117352000	THREAD TENSION POST NUT		*		2
8	14140255	WORK CLAMP FOOT BRACKET COMPL.		*		1
9	13541404	WORK CLAMP FOOT LIFTING PLATE		*		1
10	SS9151120CP	SCREW 15/64-28 L=11		*		2
11	WP0612516SD	WASHER 6.1X15.2X2.5		*		2
12	D2545232D0A	HINGE SCREW	SELECTIVE PARTS	*		2
13	D2545232D0B	HINGE SCREW	SELECTIVE PARTS	*		2
14	D2545232D0C	HINGE SCREW	SELECTIVE PARTS	*		2
15	14141055	PULLING PLATE COMPL.		*		1
16	NS6110530SP	NUT 11/64-40		*		1
17	14141105	FIXING HOOK		*		1
18	D2512232D00	TORSION SPRING		*		1
19	D2511232D00	SCREW		*		1
20	14140354	INSTALLING BASE COMPL.		*		1
21	14141402	INSTALLING SHAFT		*		1
22	RE0700000K0	E-RING 7		*		2
23	SS9110920CP	SCREW 11/64-40 L=9		*		1
24	14140909	ADJUSTING PLATE		*		1
25	D2515232D00	TORSION SPRING		*		1
26	SS7110840SP	SCREW 11/64-40 L=7.8		*		2
27	13541107	WORK CLAMP FOOT SPRING HOLDER		*		1
28	14140552	PICK-UP GUIDE COMPL.		*		1
29	SS1110640TP	SCREW 11/64-40 L= 5.5		*		2
30	D2520232D00	WORK CLAMP FOOT (LEFT)		*		1
31	D2521232D00	WORK CLAMP FOOT (RIGHT)		*		1
32	SD0550271TP	HINGE SCREW D= 5.50 H= 2.7		*		2
33	14141204	PLATE CAM		*		1
34	NS6120480SP	NUT 3/16-28		*		2
35	14140750	PREVENTING PLATE COMPL.		*		1
36	SS9110543CP	SCREW 11/64-40 L=5.3		*		2
37	SM9061403CP	SCREW M6 L=14		*		1
38	SM6061202TP	SCREW M6 L=12		*		1
39	WP0612516SD	WASHER 6.1X15.2X2.5		*		2
40	14140206	PICK-UP INSTALLING BASE		*		1
41	14141501	FINGER GUARD		*		1
42	SS7090610SP	SCREW 9/64-40 L=6		*		2
43	13541503	FEED PLATE		*		1
44	SS9110460CP	SCREW 11/64-40 L=4		*		1
45	WP0501016SD	WASHER 5X10.5X1		*		1
46	13541313	CONNECTING ARM				1
47	SM6061802TP	SCREW M6 L=18				1

LK-1901S△:WORK CLAMP MECHANISM COMPONENTS

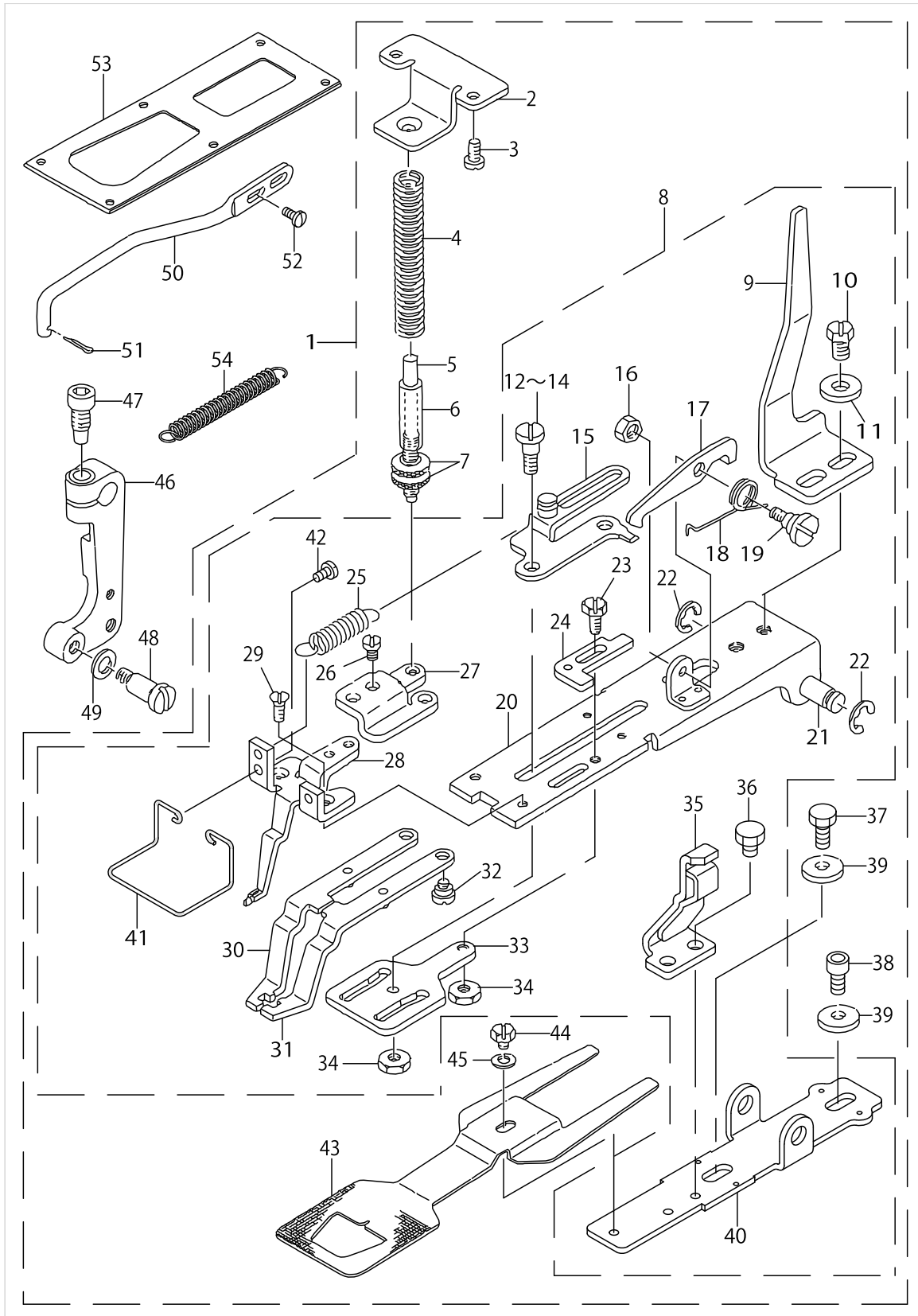

LK-1901S△:WORK CLAMP MECHANISM COMPONENTS

No.	Parts No.	Parts name	Remarks	Level	Cons	Qty
48	SD1201501SP	HINGE SCREW D=12 H=15				1
49	WP0651056SH	WASHER 6.5X11X1				1
50	13540604	DRIVING BAR B				1
51	PD02010000B	SPLIT PIN				1
52	SS7090850SP	SCREW 9/64-40 L=8				2
53	13517602	FEED PLATE PRESSER PLATE				1
54	10087906	TENTION SPRING	FOR SOLENOID TYPE			1

LK-1901:WORK CLAMP SOLENOID COMPONENTS

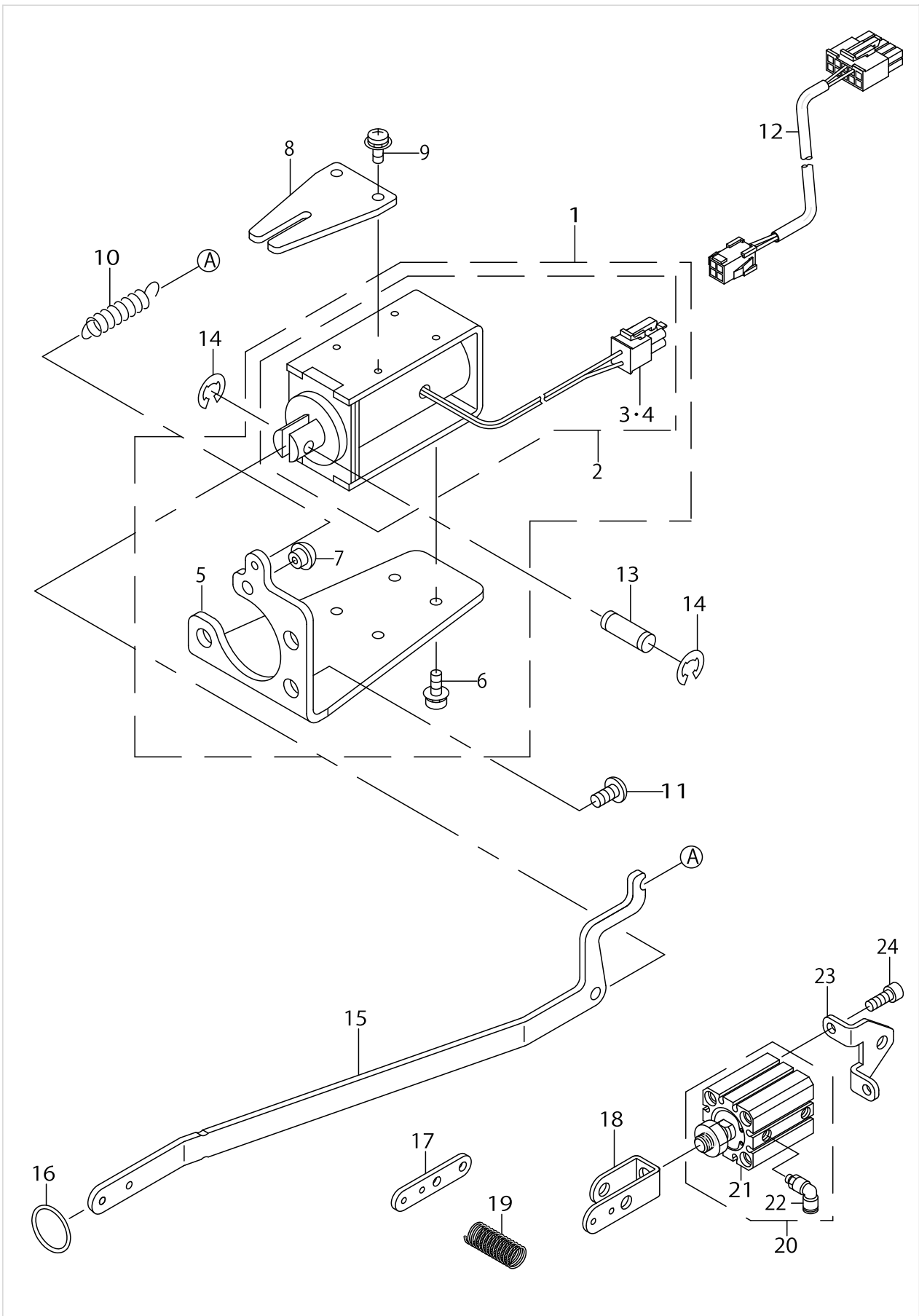

LK-1901:WORK CLAMP SOLENOID COMPONENTS

No.	Parts No.	Parts name	Remarks	Level	Cons	Qty
1	14141857	SOLENOID FOR PICK-UP ASM.				1
2	14141758	SOLENOID FOR PICK-UP COMPL.		*		1
3	HK03461004A	HOUSING,BLUE 4P		*		1
4	HK034640000	PIN CONTACT		*		2
5	14141907	SOLENOID INSTALLING BASE		*		1
6	SL4030881SC	SCREW M3X8		*		4
7	TA0550604R0	RUBBER PLUG		*		1
8	14142103	CONNECTING LINK GUIDE				1
9	SL4030681SC	SCREW M3 L=6				2
10	B1657506E00	SPRING				1
11	SS4151215SP	SCREW 15/64-28 L=12				3
12	14142251	SOLENOID RELAY CABLE ASM.				1
13	B302745000B	PIN				1
14	RC0410415KP	C-RING				2
15	14142004	WORK CLAMP CONNECTING LINK				1
16	RO044240100	RUBBER RING				1
17	14147003	SOLENOID LINK	FOR SOLENOID TYPE			1
18	14147102	CYLINDER KNUCKLE	FOR CYLINDER TYPE			1
19	14148407	VERTICAL FEED SHAFT SPRING				1
20	14147359	PRESSER LIFTING CYLINDER ASM.	FOR CYLINDER TYPE			1
21	PA2502007A0	AIR CYLINDER		*		1
22	PJ304060502	ELBOW UNION 6XM5		*		2
23	14147201	PRESSER LIFTER CYLINDER BASE	FOR CYLINDER TYPE			1
24	SM6061602TP	SCREW M6 L=16	FOR CYLINDER TYPE			2

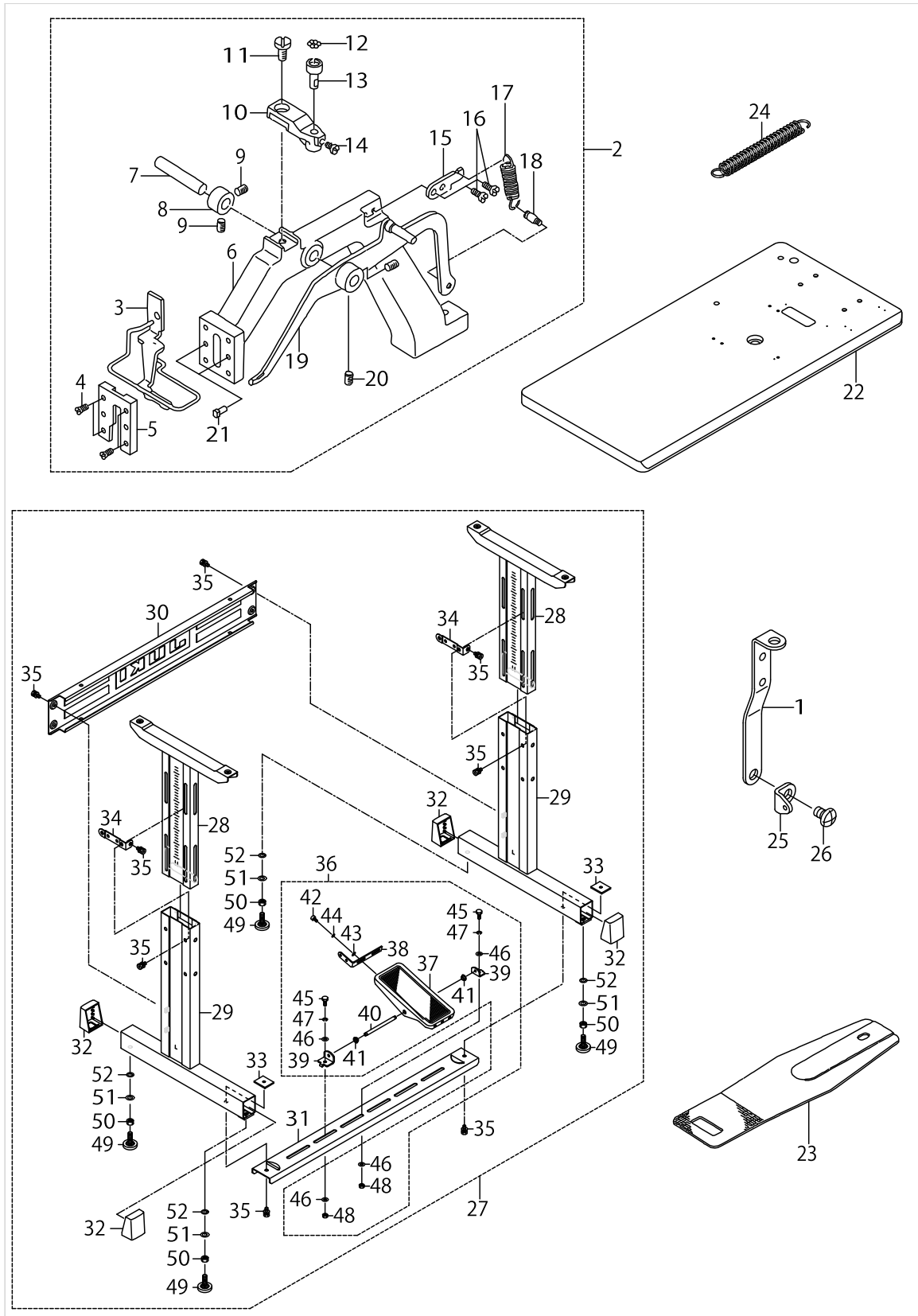

LK-1902S△

No.	Parts No.	Parts name	Remarks	Level	Cons	Qty
1	B1114581000	THREAD GUIDE PLATE				1
2	13543764	CLOTH FEED BASE ASM.				1
3	13544465	CLOTH PRESSER FOOT ASM.		*		1
4	SS2110930SP	SCREW 11/64-40 L=8.7		*		4
5	13544614	CLOTH FEED BASE COVER		*		1
6	13543715	CLOTH FEED BASE		*		1
7	B2539280000	STUD		*		1
8	CS087101BSH	THRUST COLLAR ASM. D=8.73 W=10		*		1
9	SS8150822TP	SCREW 15/64-28 L=8		*		2
10	13543806	BALL HOLDER		*		1
11	SS7151210SP	SCREW 15/64-28 L=12		*		1
12	B2549280000	WORK CLAMP FOOT MOUNTING BASE		*		7
13	B2548280000	BALL RETAINER		*		1
14	SS7110740TP	SCREW 11/64-40 L=7		*		1
15	13543905	SPRING SUSPENSION		*		1
16	SS6120940SP	SCREW 3/16-28 L=9		*		2
17	13544705	SPRING		*		1
18	B3413552000	SUSPENSION SCREW		*		1
19	13544051	LIFTING LEVER ASM.		*		1
20	SS8150822TP	SCREW 15/64-28 L=8		*		2
21	B1816280000	GUIDE PIN		*		2
22	14144000	LATERA INSTALLATION TYPE TABLE				1
23	14143002	FEED PLATE				1
24	10087906	TENTION SPRING	FOR SOLENOID TYPE			1
25	13786306	THREAD GUIDE NO.1				1
26	SS4150915SP	SCREW 15/64-28 L=9				1
27	14118350	T-STAND COMPL.				1
28	B8101210AAB	UPPER STAND ASM.		*		2
29	B8105210AAA	STAND ASM.		*		2
30	11158300	STAND SIDE SUPPORT		*		1
31	11158409	STAND SIDE SUPPORT		*		1
32	11158607	RUBBER CAP		*		4
33	17007402	NUT		*		2
34	11158516	UPPER STAND PLATE		*		2
35	SL9082091SE	WASHER HEXAGONAL BOLT		*		12
36	13817754	Z-STAND PEDAL ASM.		*		1
37	GPF060600A0	PEDAL ASM.		*		1
38	GPF06080000	PEDAL ADJUSTING PLATE		*		1
39	11159001	PEDAL SHAFT BRACKET		*		2
40	B8153771000	PEDAL CONNECTING ROD		*		1
41	D8113555B00	PEDAL BUSHING		*		2
42	SM9061203SE	SCREW M6 L=12		*		2
43	WP0671016SE	WASHER 6.7X13X1		*		2
44	WS0621210KR	SPRING WASHER 6.2X11.4X1.2		*		2
45	SM9082023SE	SCREW M8 L=20		*		2
46	WP0871602SE	WASHER 8.7X18X1.6		*		4
47	WS0861410KR	SPRING WASHER 8.6X15X1.4		*		2

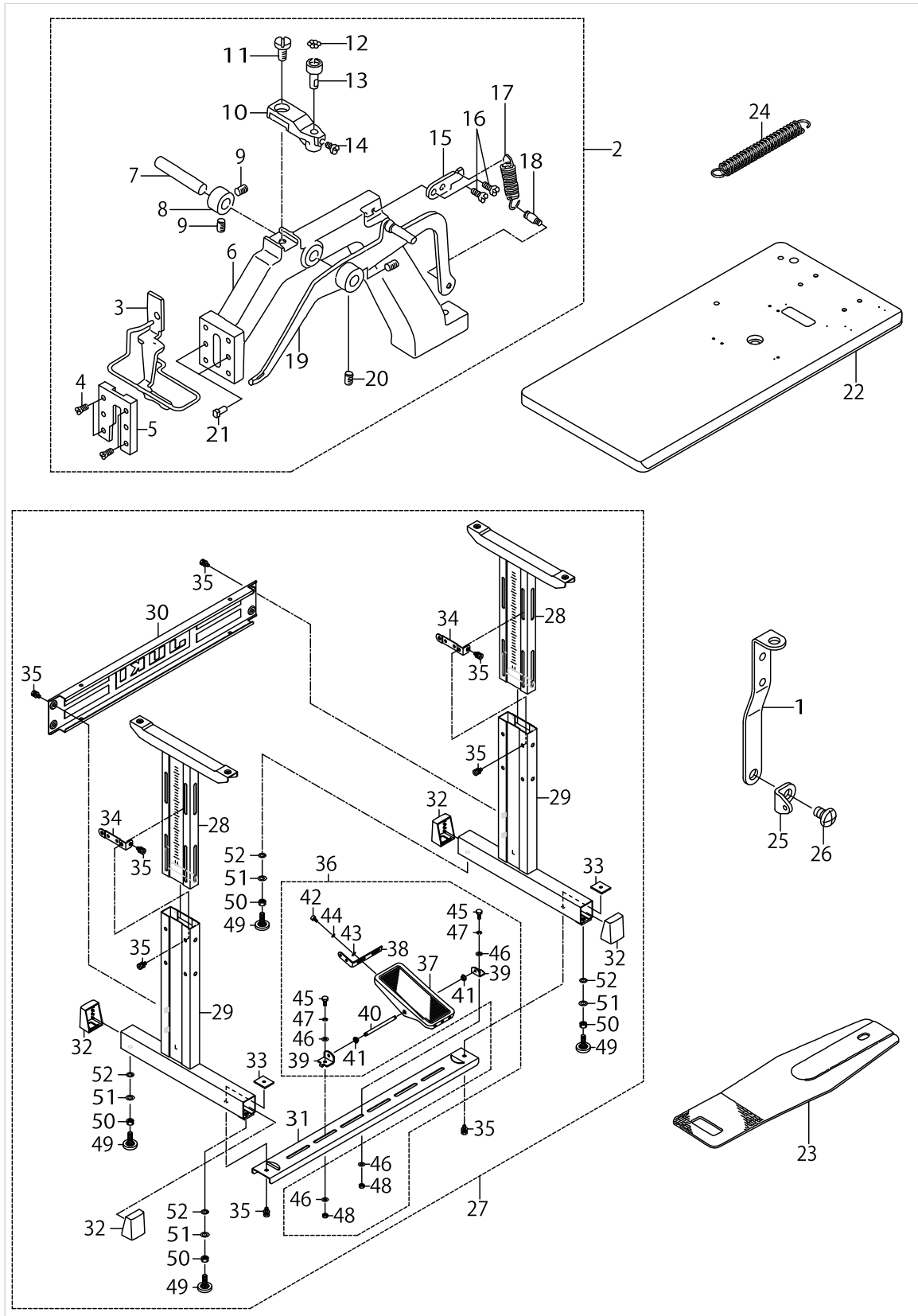

LK-1902S△

No.	Parts No.	Parts name	Remarks	Level	Cons	Qty
48	NM6080721SE	NUT M8		*		2
49	B81085550A0	ADJUSTING SCREW ASM. WITH CAP		*		4
50	NM6120001SE	NUT M12		*		4
51	WP1302501SE	WASHER M12		*		4
52	WS1253010KN	SPRING WASHER 12.5X21.5X3		*		4

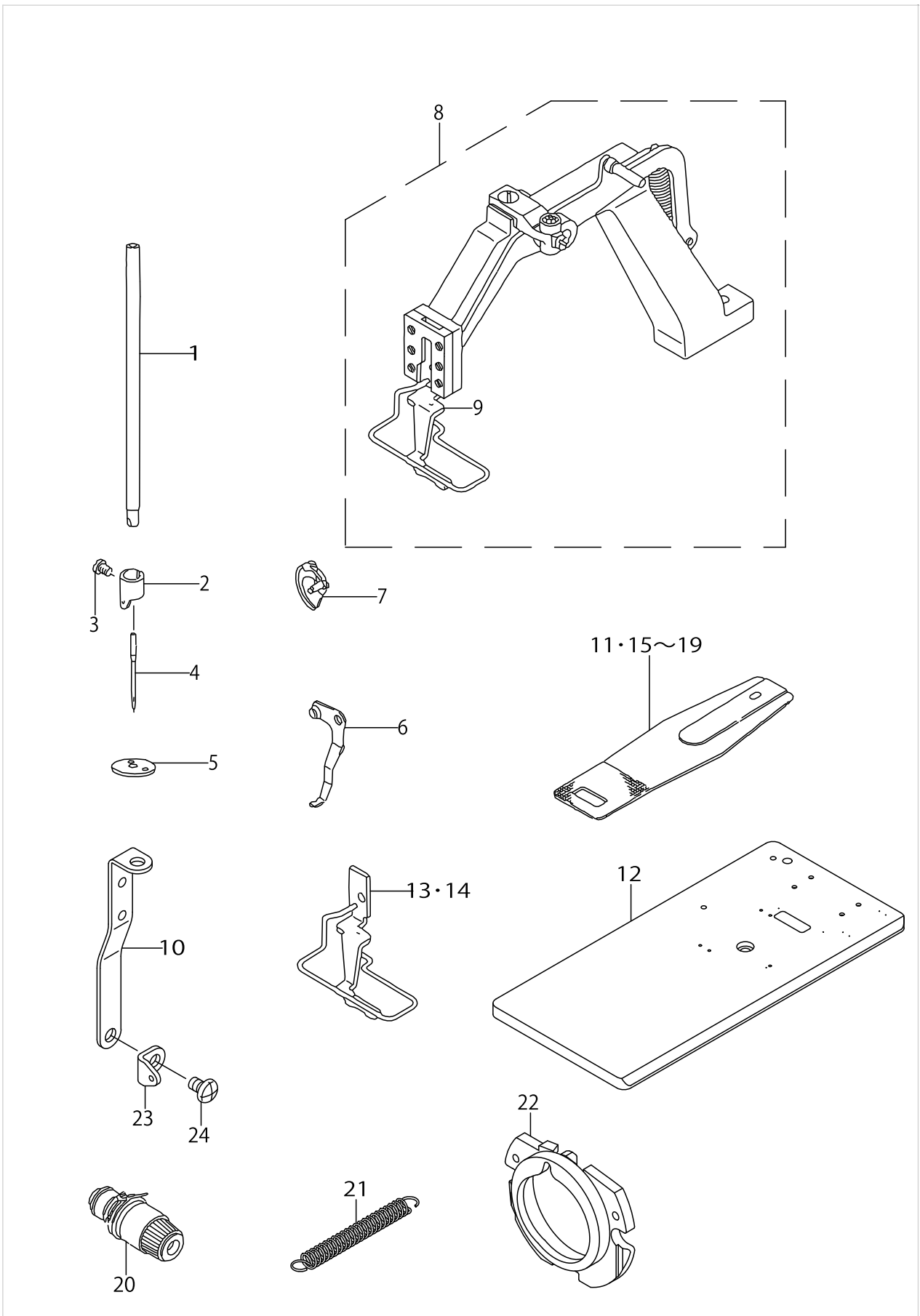

LK-1902H△

No.	Parts No.	Parts name	Remarks	Level	Cons	Qty
1	D1401L7VV00	NEEDLE BAR				1
2	D1405L7AM00	NEEDLE BAR THREAD GUIDE				1
3	SS7080510TP	SCREW 1/8-44 L=4.5				1
4	MDP170B1900	NEEDLE DPX17 #19				1
5	14109607	NEEDLE HOLE GUIDE				1
6	D2101L7AMA0	WIPER ASM.				1
7	D1818282N00	SHUTTLE				1
8	13543764	CLOTH FEED BASE ASM.	COMMON USE WITH LK-1902S△			1
9	13544465	CLOTH PRESSER FOOT ASM.	COMMON USE WITH LK-1902S△	*		1
10	B1114581000	THREAD GUIDE PLATE	COMMON USE WITH LK-1902S△			1
11	14143002	FEED PLATE				1
12	14144000	LATERA INSTALLATION TYPE TABLE				1
13	13545660	WORK CLAMP FOOT ASM.	SPECIAL ORDER PARTS			1
14	13547161	WORK CLAMP FOOT ASM.	SPECIAL ORDER PARTS			1
15	13545504	FEED PLATE	SPECIAL ORDER PARTS			1
16	13545801	FEED PLATE	SPECIAL ORDER PARTS			1
17	13547005	FEED PLATE	SPECIAL ORDER PARTS			1
18	13546700	CLOTH PRESSER PLATE	SPECIAL ORDER PARTS			1
19	13548706	CLOTH PRESSER LOWER PLATE	SPECIAL ORDER PARTS			1
20	B23022050A0	TENSION CONTROLLER NO.2 ASM.				1
21	10087906	TENTION SPRING				1
22	14103659	SHUTTLE RACE RING ASM.,C				1
23	13786306	THREAD GUIDE NO.1				1
24	SS4150915SP	SCREW 15/64-28 L=9				1

THREAD TENSION COMPONENTS
針棒・糸調子関係

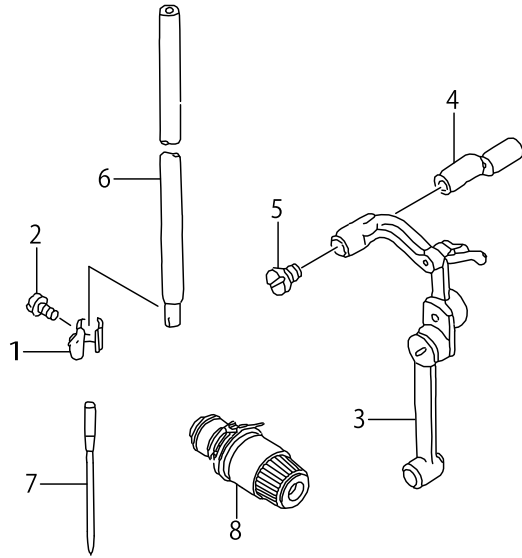

PRESSER LIFTER COMPONENTS
押え上げ関係

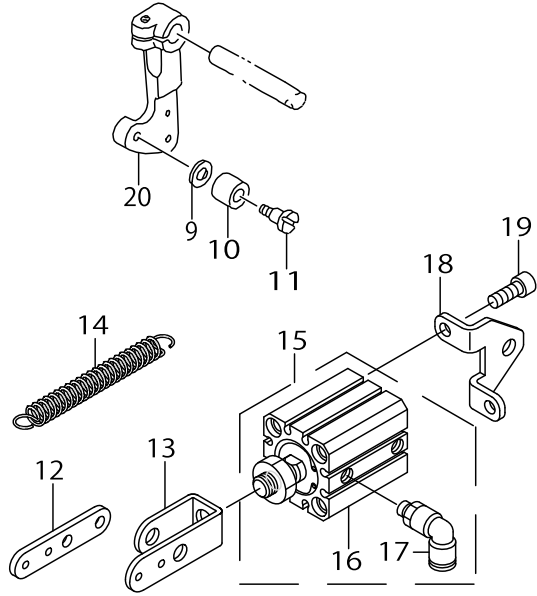

WIPER MECHANISM COMPONENTS
ワイパー関係

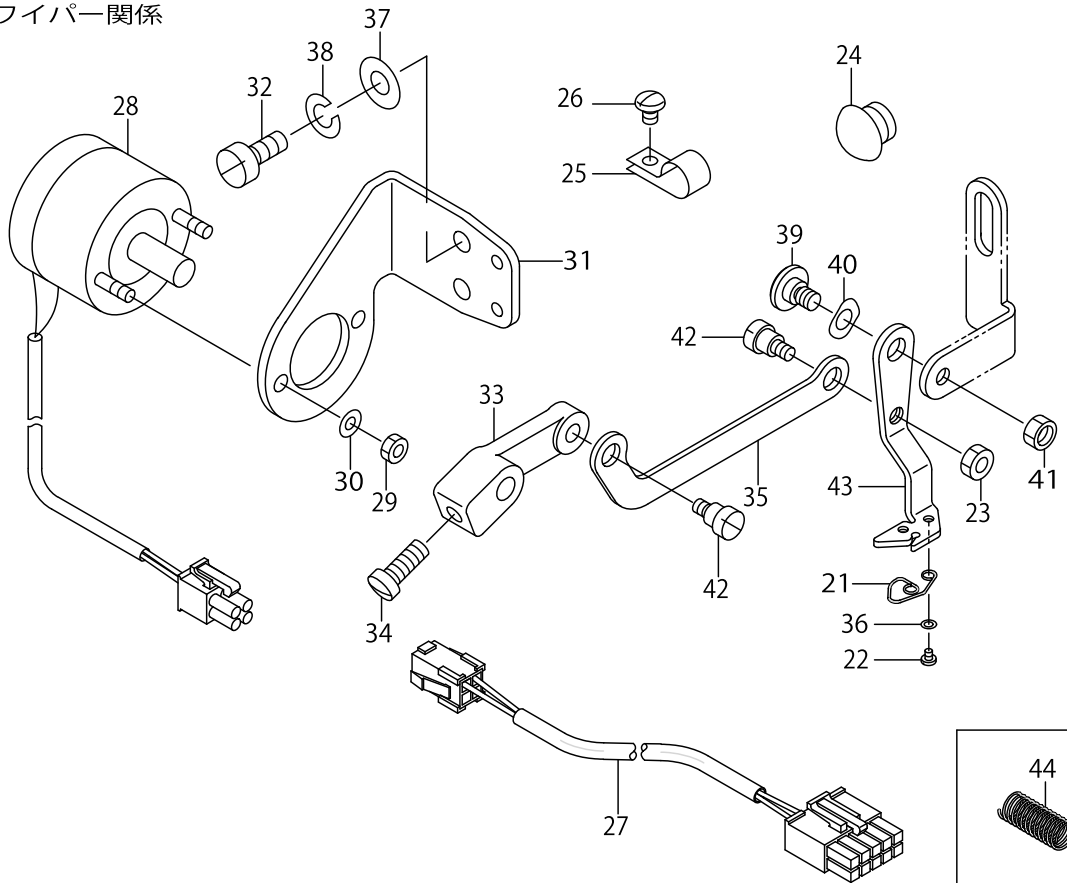

LK-1903S△-30△

No.	Parts No.	Parts name	Remarks	Level	Cons	Qty
1	D1405M7WF00	NEEDLE BAR THREAD GUIDE				1
2	SS7080510TP	SCREW 1/8-44 L=4.5				1
3	D1901L7VVB0	THREAD TAKE-UP LEVER ASM.				1
4	D1904L7VV00	LINK TAKE-UP LEVER PIN, HEAVY				1
5	D1906L7VV00	SET SCREW				1
6	D1401L7VV00	NEEDLE BAR				1
7	MDP170B1400	NEEDLE DPX17 #14				1
8	B23022050A0	TENSION CONTROLLER NO.2 ASM.				1
9	B185351200E	HOOK SHAFT WASHER				1
10	B2619372000	STOP MOTION TRIPPING LEVER CAM				1
11	SD0791271SP	HINGE SCREW D= 7.94 H=12.7				1
12	14147003	SOLENOID LINK	FOR SOLENOID TYPE			1
13	14147102	CYLINDER KNUCKLE	FOR CYLINDER TYPE			1
14	10087906	TENTION SPRING	FOR SOLENOID TYPE			1
15	14147359	PRESSER LIFTING CYLINDER ASM.	FOR CYLINDER TYPE			1
16	PA2502007A0	AIR CYLINDER		*		1
17	PJ304060502	ELBOW UNION 6XM5		*		2
18	14147201	PRESSER LIFTER CYLINDER BASE	FOR CYLINDER TYPE			1
19	SM6061602TP	SCREW M6 L=16	FOR CYLINDER TYPE			2
20	13541313	CONNECTING ARM				1
21	40009860	WIPER THREAD CATCH SPRING	EXCEPT LK-1903-305			1
22	SS7060310SP	SCREW 3/32-56 L=3	EXCEPT LK-1903-305			2
23	NS6110310SP	NUT 11/64-40				1
24	TA1250705R0	RUBBER PLUG				1
25	HX00123000C	CABLE CLIP				3
26	SS4110615SP	SCREW 11/64-40 L=6	EXCEPT LK-1903-305			3
27	14142251	SOLENOID RELAY CABLE ASM.				1
28	14147755	SOLENOID FOR WIPER ASM.				1
29	NM6040003SC	NUT M4				2
30	WS0410002KS	SPRING WASHER M4				2
31	13864509	SOLENOID FITTING PLATE				1
32	SS6111010TP	SCREW 11/64-40 L= 9.5				2
33	B210220500A	WIPER ARM				1
34	SS7111120SP	SCREW 11/64-40 L=10.5				1
35	14147607	WIPER LINK				1
36	WP0280500SC	WASHER				1
37	WP0450801SD	WASHER 4.5X10X0.8				2
38	WS0451040KP	SPRING WASHER 4.5X8.5X1				2
39	SD0640261SP	HINGE SCREW D=3.65 H=2.6	EXCEPT LK-1903-305			1
40	WZ0640200KP	WAVE WASHER	EXCEPT LK-1903-305			1
41	NS6120310SP	NUT 3/16-28	EXCEPT LK-1903-305			1
42	SD0600181TP	HINGE SCREW				2
43	40009859	WIPER	EXCEPT LK-1903-305			1
44	14148407	VERTICAL FEED SHAFT SPRING				1

LK-1903-301:BUTTON CLAMP COMPL. FOR SMALL-BUTTONS

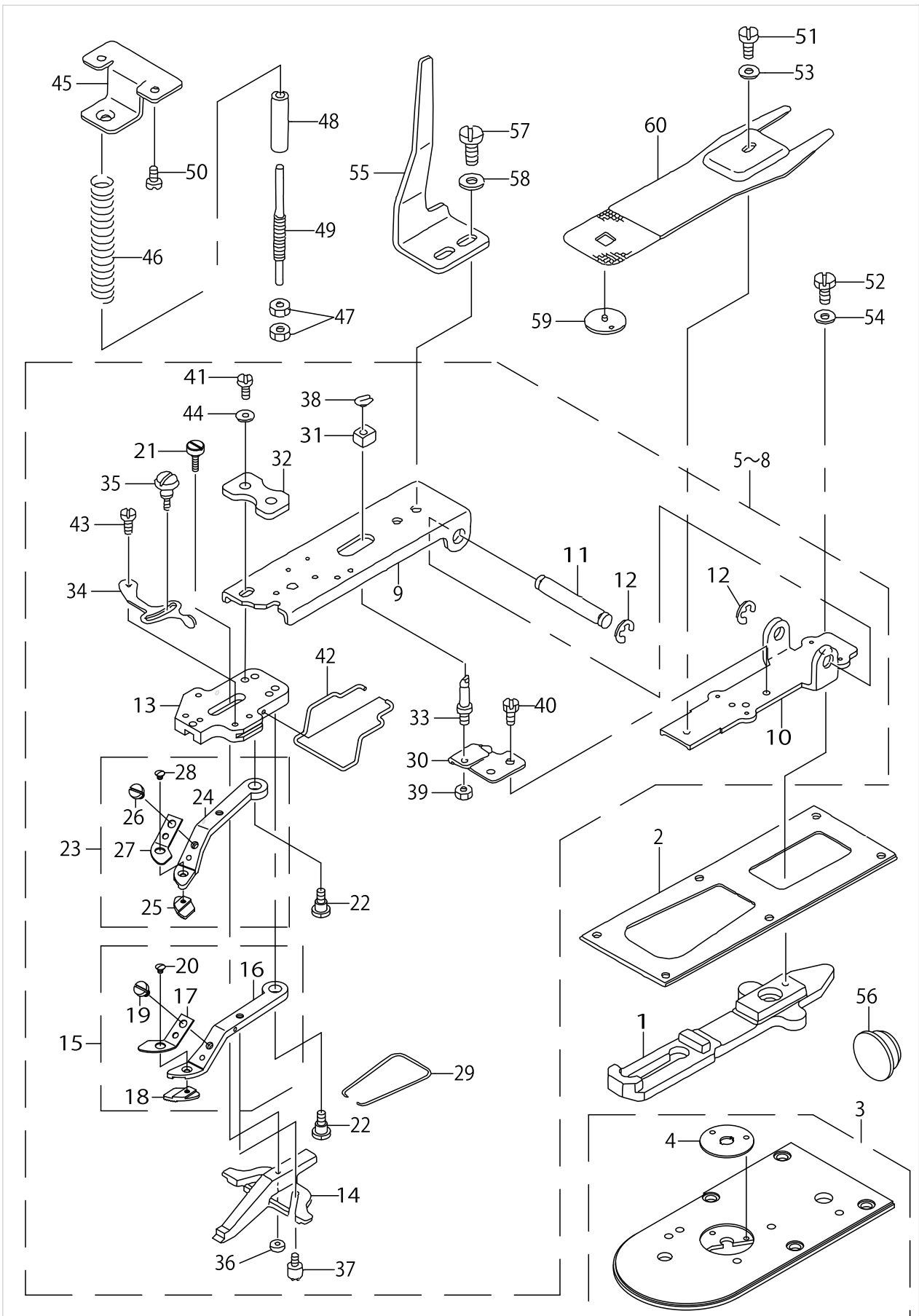

LK-1903-301:BUTTON CLAMP COMPL. FOR SMALL-BUTTONS

No.	Parts No.	Parts name	Remarks	Level	Cons	Qty
1	14145106	CLOTH FEED PLATE				1
2	13517602	FEED PLATE PRESSER PLATE				1
3	14149256	NEEDLE PLATE J				1
4	MAZ15501000	GUIDE		*		1
5	14145551	SMALL CLAMP MECHANISM ASM.	FOR LK-1903-301			1
6	14145650	MEDIUM CLAMP MECHANISM ASM.	FOR LK-1903-302			1
7	14145759	LARGE CLAMP MECHANISM ASM.	FOR LK-1903-303			1
8	14145858	VERY SMALL CLAMP MECHANISM ASM	FOR LK-1903-304			1
9	14146203	PICK-UP FOOT INSTALLING BASE		*		1
10	14146104	PICK-UP INSTALLING BASE		*		1
11	14141402	INSTALLING SHAFT		*		1
12	RE0700000K0	E-RING 7		*		2
13	14146302	PICK-UP FOOT INSTALLING BASE		*		1
14	B2552372000	BUTTON CLAMP SLIDE		*		1
15	14148852	SMALL CLAMP JAW LEVER ASM.,R	FOR LK-1903-301	*		1
16	MAZ15507000	SMALL CLAMP JAW LEVER ASM.,L		*		1
17	MAZ15509000	SPRING, RIGHT		*		1
18	14148803	PLATE K, R		*		1
19	SS7090410SP	SCREW 9/64-40 L= 3.5		*		1
20	SS2060310SP	SCREW 3/32-56 L=3		*		1
21	SD0550303TP	HINGE SCREW D=5.5 H=3		*		1
22	SD0640391TP	HINGE SCREW D= 6.35 H= 3.9		*		2
23	14148951	SMALL CLAMP JAW LEVER ASM.,L	FOR LK-1903-301	*		1
24	MAZ15508000	SMALL CLAMP JAW LEVER, L		*		1
25	14148902	PLATE K, L		*		1
26	SS7090410SP	SCREW 9/64-40 L= 3.5		*		1
27	MAZ15510000	SPRING, LEFT		*		1
28	SS2060310SP	SCREW 3/32-56 L=3		*		1
29	MAZ15513000	BUTTON CLAMP JAW LEVER SPRING		*		1
30	MAZ15514000	SUPPORT PLATE		*		1
31	MAZ15515000	SLIDE BLOCK		*		1
32	14146401	PRESSER PLATE		*		1
33	13540901	STATIONING BLOCK SHAFT		*		1
34	B2548372000	SNAP FASTENER CLAMP STOP LEVER		*		1
35	B2549372000	CLAMP SCREW A		*		1
36	B2553372000	NUT		*		1
37	B2560372000	BUTTON CLAMP STOP PIN		*		2
38	D2548232D00	SNAP RING,FOR CONNECTING ROD		*		1
39	NS6150310SP	NUT 15/64-28		*		1
40	SS9110460CP	SCREW 11/64-40 L=4		*		2
41	SS9621413SP	SCREW 3/16-32 L=13.5		*		2
42	D3130M1YC00	FINGER GUARD		*		1
43	SD0550181SP	HINGE SCREW D= 5.50 H= 1.8		*		1
44	WP0501016SD	WASHER 5X10.5X1		*		2
45	13811906	ACCEPT PLATE, UPPER				1
46	13812003	PRESSURE SPRING				1
47	B3125012000	THREAD TENSION NUT				2

LK-1903-301:BUTTON CLAMP COMPL. FOR SMALL-BUTTONS

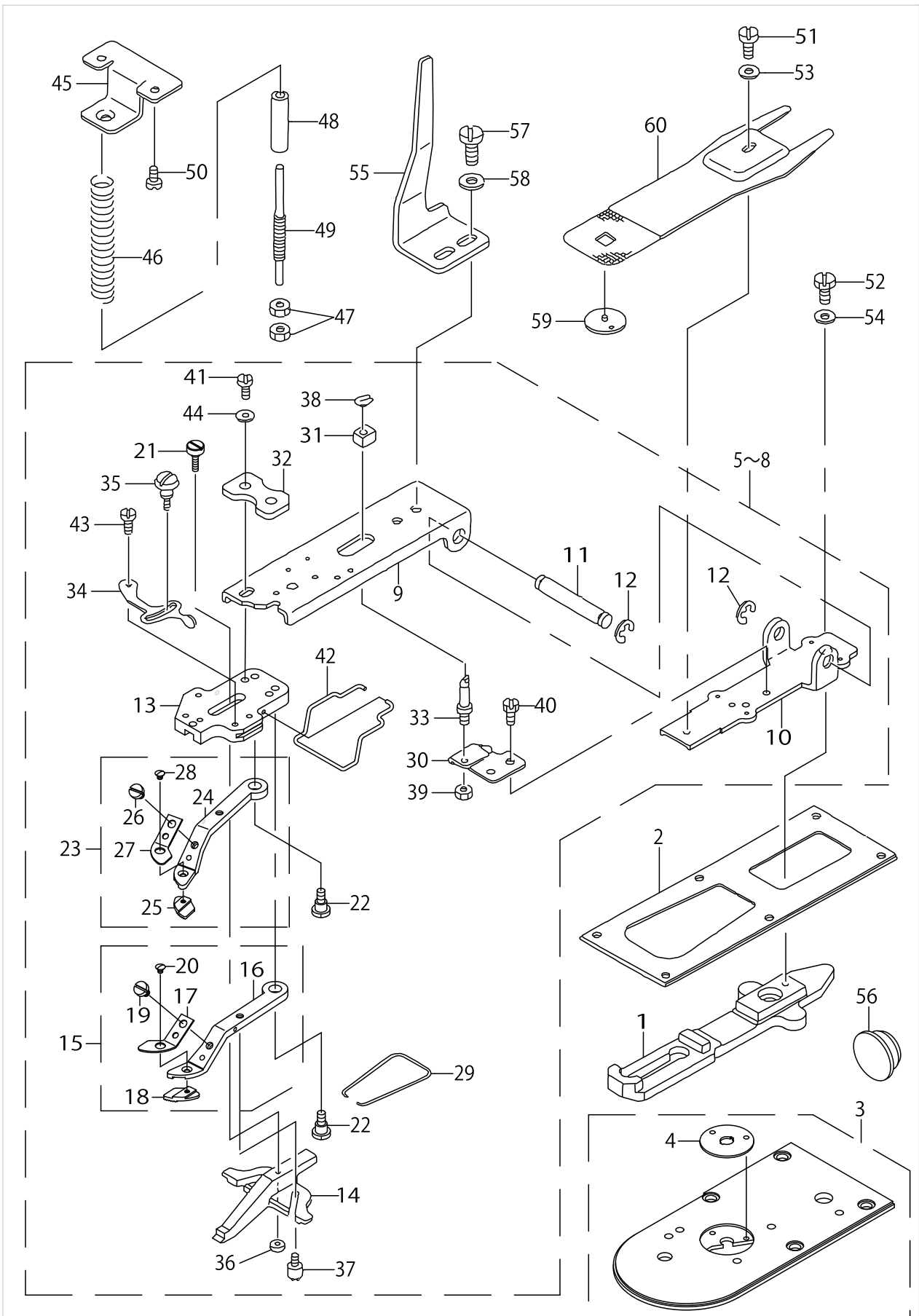

LK-1903-301:BUTTON CLAMP COMPL. FOR SMALL-BUTTONS

No.	Parts No.	Parts name	Remarks	Level	Cons	Qty
48	D2527232D00	SLEEVE				1
49	14146906	ADJUSTING SHAFT				1
50	SS7110840SP	SCREW 11/64-40 L=7.8				2
51	SS9110543CP	SCREW 11/64-40 L=5.3				1
52	SM6061202TP	SCREW M6 L=12				1
53	WP0501016SD	WASHER 5X10.5X1				1
54	WP0612516SD	WASHER 6.1X15.2X2.5				1
55	MAZ15516000	MOVING PLATE				1
56	TA2100904R0	RUBBER PLUG				1
57	SS9151120CP	SCREW 15/64-28 L=11				2
58	WP0612516SD	WASHER 6.1X15.2X2.5				2
59	14149603	NEEDLE HOLE GUIDE				1
60	MAZ15502000	PRESSURE PLATE				1

LK-1903-302:BUTTON CLAMP COMPL. FOR MEDIUM-SIZED BUTTONS
 L K - 1 9 0 3 - 3 0 2 : 中ボタン用部品

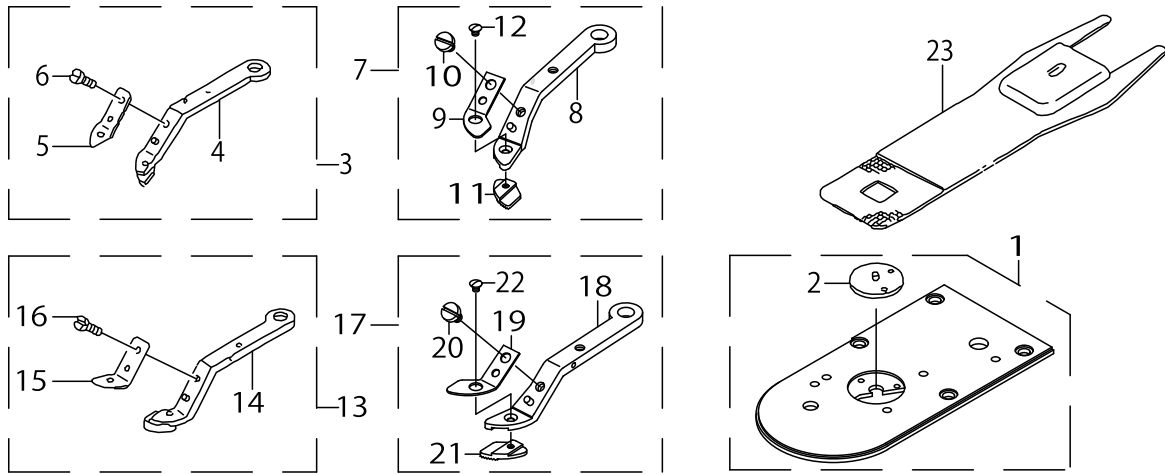

LK-1903-303:BUTTON CLAMP COMPL. FOR LARGE-SIZED BUTTONS
 L K - 1 9 0 3 - 3 0 3 : 大ボタン用部品

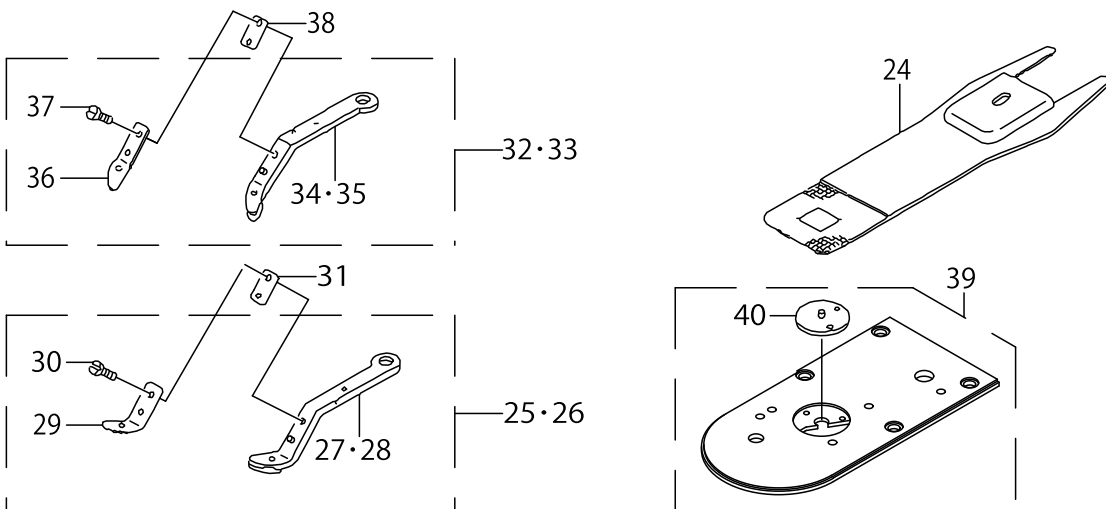

LK-1903-304:BUTTON CLAMP COMPL. FOR VERY SMALL-SIZED BUTTONS
 L K - 1 9 0 3 - 3 0 4 : 極小ボタン用部品

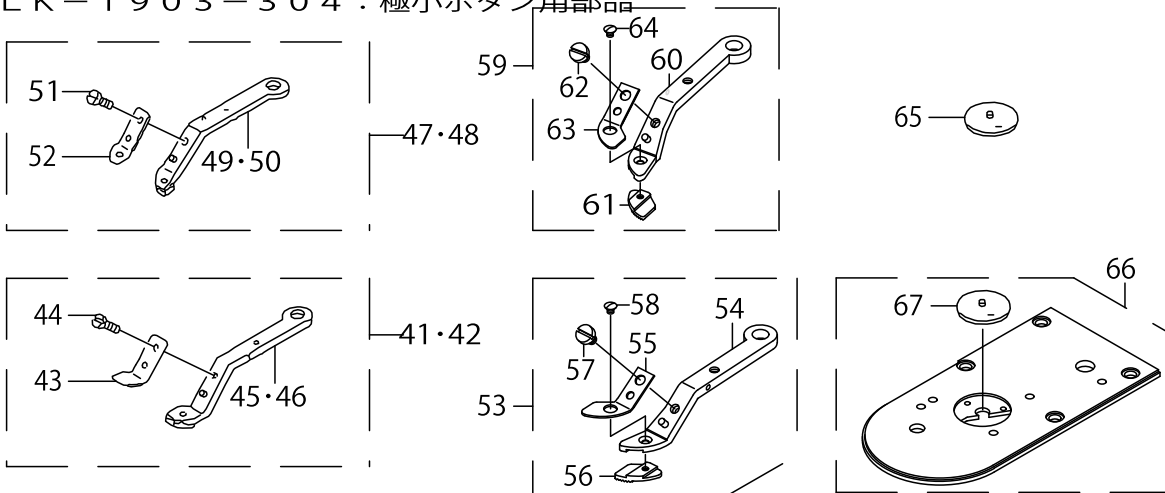

No.	Parts No.	Parts name	Remarks	Level	Cons	Qty
1	14149355	NEEDLE PLATE ASM., K				1
2	MAZ15601000	GUIDE		*		1
3	MAZ155080B0	SMALL CLAMP JAW LEVER ASM.,L	SPECIAL ORDER PARTS			1
4	MAZ155080A0	SMALL CLAMP JAW LEVER ASM.,L		*		1
5	MAZ15510000	SPRING, LEFT		*		1
6	SS7090410SP	SCREW 9/64-40 L= 3.5		*		1
7	14149157	MIDDLE CLAMP JAW LEVER ASM.,L				1
8	MAZ15508000	SMALL CLAMP JAW LEVER, L		*		1
9	MAZ15510000	SPRING, LEFT		*		1
10	SS7090410SP	SCREW 9/64-40 L= 3.5		*		1
11	14149108	PLATE L, L		*		1
12	SS2060310SP	SCREW 3/32-56 L=3		*		1
13	MAZ155070B0	SMALL CLAMP JAW LEVER ASM.,R	SPECIAL ORDER PARTS			1
14	MAZ155070A0	SMALL CLAMP JAW LEVER ASM.,R		*		1
15	MAZ15509000	SPRING, RIGHT		*		1
16	SS7090410SP	SCREW 9/64-40 L= 3.5		*		1
17	14149058	MIDDLE CLAMP JAW LEVER ASM.,R				1
18	MAZ15507000	SMALL CLAMP JAW LEVER ASM.,L		*		1
19	MAZ15507000	SMALL CLAMP JAW LEVER ASM.,L		*		1
20	SS7090410SP	SCREW 9/64-40 L= 3.5		*		1
21	14149009	PLATE L, R		*		1
22	SS2060310SP	SCREW 3/32-56 L=3		*		1
23	MAZ15602000	PRESSURE PLATE				1
24	MAZ15702000	PRESSURE PLATE				1
25	MAZ157070BB	LARGE CLAMP JAW LEVER ASM.,R				1
26	MAZ157070BA	LARGE CLAMP JAW LEVER ASM.,R	SPECIAL ORDER PARTS			1
27	MAZ157070AA	LARGE CLAMP JAW LEVER ASM.,R	SPECIAL ORDER PARTS	*		1
28	MAZ157070AB	LARGE CLAMP JAW LEVER ASM.,R		*		1
29	MAZ15709000	SPRING,RIGHT		*		1
30	SS7090410SP	SCREW 9/64-40 L= 3.5		*		1
31	MAZ15715000	SPACER	SPECIAL ORDER PARTS			1
32	MAZ157080BA	LARGE CLAMP JAW LEVER ASM.,L	SPECIAL ORDER PARTS			1
33	MAZ157080BB	LARGE CLAMP JAW LEVER ASM.,L				1
34	MAZ157080AA	LARGE CLAMP JAW LEVER ASM.,R	SPECIAL ORDER PARTS	*		1
35	MAZ157080AB	LARGE CLAMP JAW LEVER ASM.,R		*		1
36	MAZ15710000	SPRING,LEFT		*		1
37	SS7090410SP	SCREW 9/64-40 L= 3.5		*		1
38	MAZ15715000	SPACER	SPECIAL ORDER PARTS			1
39	14149454	NEEDLE PLATE ASM. L				1
40	MAZ15701000	GUIDE		*		1
41	MAZ158070BB	EXTRA SMALL CLAMP LEVER ASM.,R				1
42	MAZ158070BA	EXTRA SMALL CLAMP LEVER ASM.,L	SPECIAL ORDER PARTS			1
43	MAZ15809000	SPRING,RIGHT		*		1
44	SS7090410SP	SCREW 9/64-40 L= 3.5		*		1
45	MAZ158070AB	EXTRA SMALL CLAMP LEVER ASM.,L		*		1
46	MAZ158070AA	EXTRA SMALL CLAMP LEVER ASM.,L	SPECIAL ORDER PARTS	*		1
47	MAZ158080BA	EXTRA SMALL CLAMP LEVER ASM.,L	SPECIAL ORDER PARTS			1

LK-1903-302:BUTTON CLAMP COMPL. FOR MEDIUM-SIZED BUTTONS
 L K - 1 9 0 3 - 3 0 2 : 中ボタン用部品

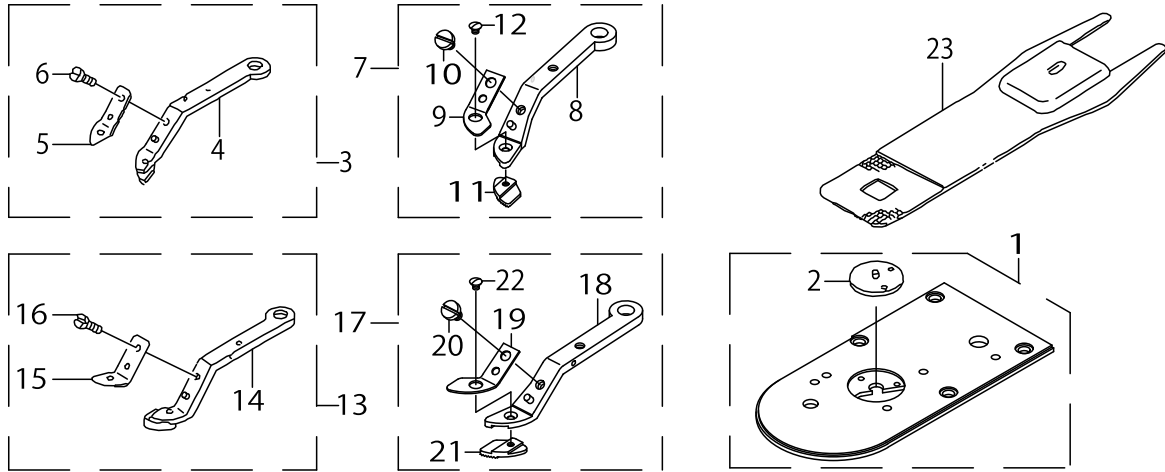

LK-1903-303:BUTTON CLAMP COMPL. FOR LARGE-SIZED BUTTONS
 L K - 1 9 0 3 - 3 0 3 : 大ボタン用部品

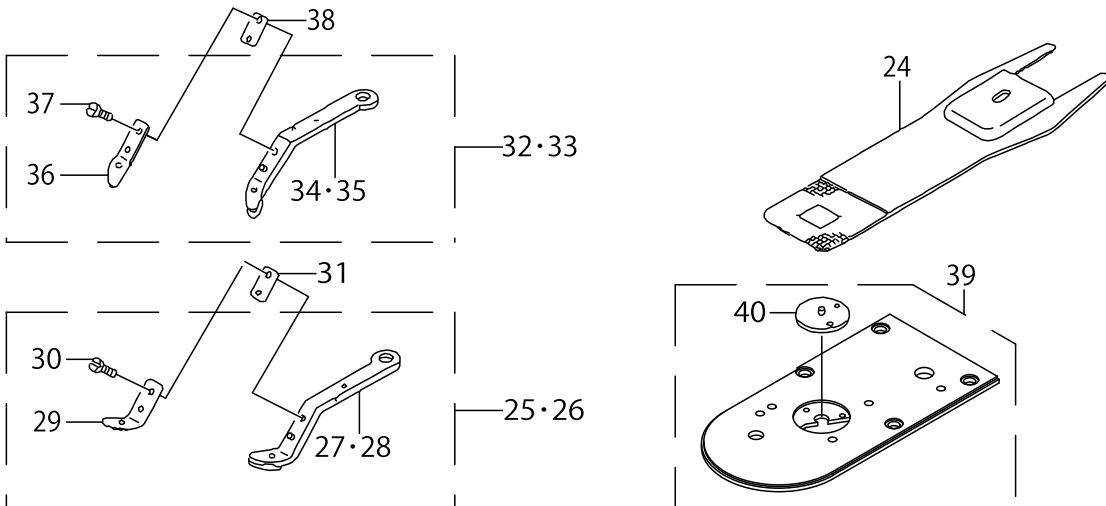

LK-1903-304:BUTTON CLAMP COMPL. FOR VERY SMALL-SIZED BUTTONS
 L K - 1 9 0 3 - 3 0 4 : 極小ボタン用部品

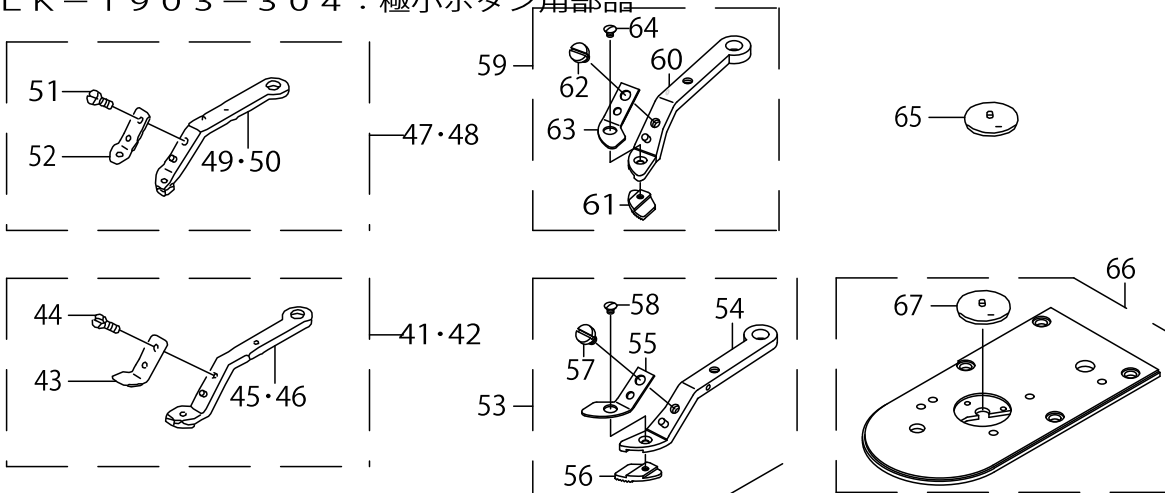

No.	Parts No.	Parts name	Remarks	Level	Cons	Qty
48	MAZ158080BB	EXTRA SMALL CLAMP LEVER ASM.,L				1
49	MAZ158080AA	EXTRA SMALL CLAMP LEVER ASM.,L	SPECIAL ORDER PARTS	*		1
50	MAZ158080AB	EXTRA SMALL CLAMP LEVER ASM.,L		*		1
51	SS7090410SP	SCREW 9/64-40 L= 3.5		*		1
52	MAZ15810000	SPRING,LEFT		*		1
53	14148852	SMALL CLAMP JAW LEVER ASM.,R	ACCESSORIE PARTS			1
54	MAZ15507000	SMALL CLAMP JAW LEVER ASM.,L		*		1
55	MAZ15509000	SPRING, RIGHT		*		1
56	14148803	PLATE K, R		*		1
57	SS7090410SP	SCREW 9/64-40 L= 3.5		*		1
58	SS2060310SP	SCREW 3/32-56 L=3		*		1
59	14148951	SMALL CLAMP JAW LEVER ASM.,L	ACCESSORIE PARTS			1
60	MAZ15508000	SMALL CLAMP JAW LEVER, L		*		1
61	14148902	PLATE K, L		*		1
62	SS7090410SP	SCREW 9/64-40 L= 3.5		*		1
63	MAZ15510000	SPRING, LEFT		*		1
64	SS2060310SP	SCREW 3/32-56 L=3		*		1
65	14149900	NEEDLE HOLE GUIDE	OPTIONAL PARTS			1
66	14149553	NEEDLE PLATE ASM., M				1
67	MAZ15801000	GUIDE		*		1

LK-1903-305:SHANK BUTTON CLAMP MECHANISM COMPONENTS

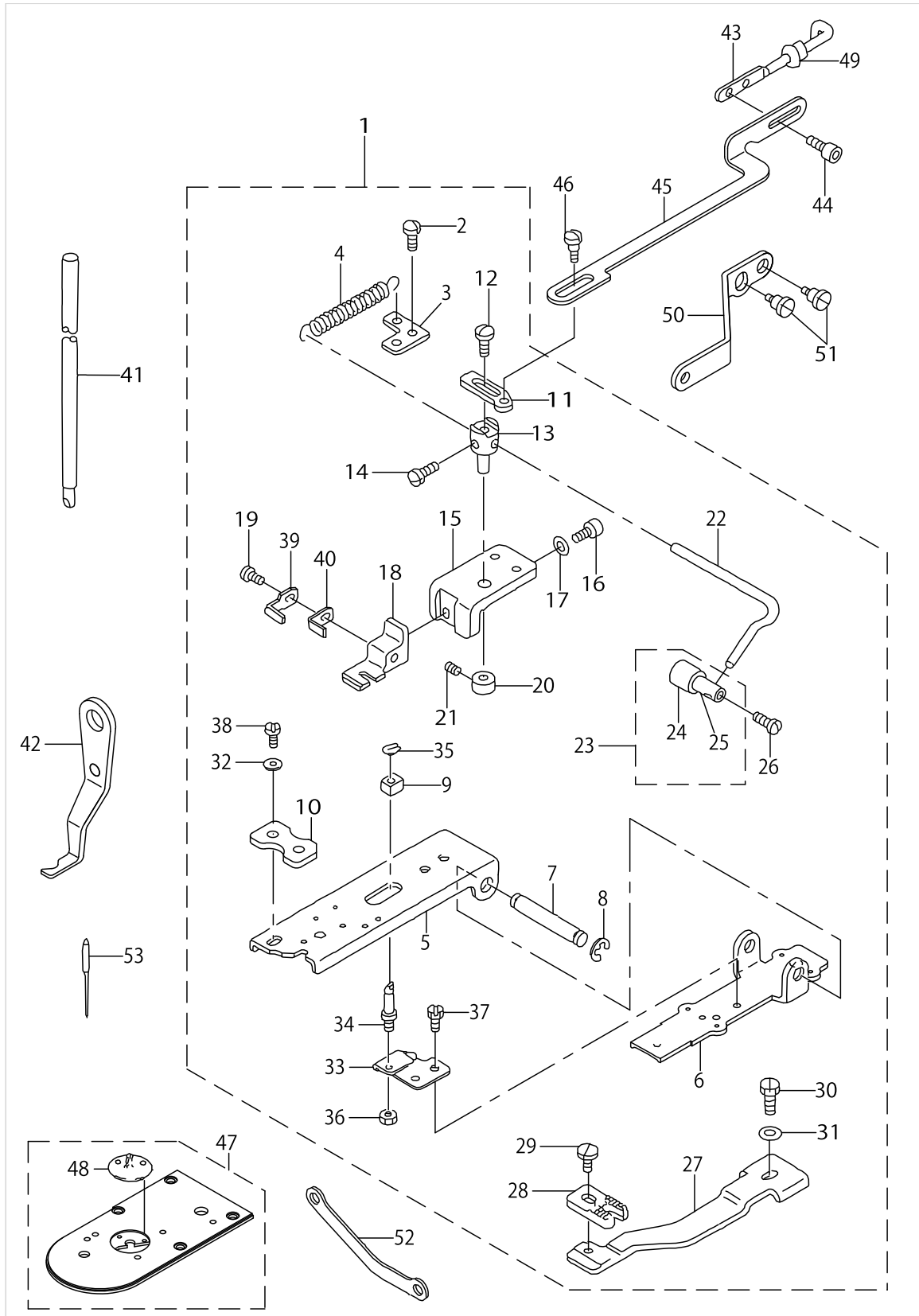

LK-1903-305:SHANK BUTTON CLAMP MECHANISM COMPONENTS

No.	Parts No.	Parts name	Remarks	Level	Cons	Qty
1	14146054	PICK-UP DEVICE COMPL.				1
2	SS7110740TP	SCREW 11/64-40 L=7		*		2
3	MAZ16012000	LEVER SPRING HOOK		*		1
4	MAZ16013000	BUTTON SUPPORT LEVER SPRING		*		1
5	14146203	PICK-UP FOOT INSTALLING BASE		*		1
6	14146104	PICK-UP INSTALLING BASE		*		1
7	14141402	INSTALLING SHAFT		*		1
8	RE0700000K0	E-RING 7		*		2
9	MAZ15515000	SLIDE BLOCK		*		1
10	14146401	PRESSER PLATE		*		1
11	MAZ16014000	BUTTON SUPPORT RELEASE LEVER		*		1
12	SS7110740TP	SCREW 11/64-40 L=7		*		1
13	MAZ16011000	BUTTON SUPPORT LEVER SHAFT		*		1
14	SS7110740TP	SCREW 11/64-40 L=7		*		1
15	MAZ16004000	BUTTON CLAMP BASE		*		1
16	SS6111052TP	SCREW		*		1
17	WP0482086SD	WASHER 4.8X11.5X2		*		1
18	MAZ16005000	BUTTON CLAMP BASE		*		1
19	SS7090510SP	SCREW 9/64-40 L= 4.6		*		1
20	CS0640811SP	THRUST COLLAR D=6.35 W=8		*		1
21	SS8110410TP	SCREW 11/64-40 L= 3.5		*		1
22	MAZ16010000	BUTTON SUPPORT LEVER		*		1
23	MAZ160090A0	BUTTON SUPPORT RUBBER ASM.		*		1
24	MAZ16009000	BUTTON SUPPORT RUBBER		*		1
25	B2406372000	SHANK BUTTON HOLDING CLAMP		*		1
26	SS7110740TP	SCREW 11/64-40 L=7		*		1
27	MAZ16002000	FEED PLATE		*		1
28	MAZ1600300A	FEED PLATE, A		*		1
29	SS6110480SP	SCREW 11/64-40 L=4.3		*		1
30	SS9111010SP	SCREW 11/64-40 L=9.5		*		1
31	WP0482086SD	WASHER 4.8X11.5X2		*		1
32	WP0501016SD	WASHER 5X10.5X1		*		2
33	MAZ15514000	SUPPORT PLATE		*		1
34	13540901	STATIONING BLOCK SHAFT		*		1
35	D2548232D00	SNAP RING, FOR CONNECTING ROD		*		1
36	NS6150310SP	NUT 15/64-28		*		1
37	SS9110460CP	SCREW 11/64-40 L=4		*		2
38	SS9621413SP	SCREW 3/16-32 L=13.5		*		2
39	MAZ16022000	BUTTON CLAMP SUPPORT, FRONT		*		1
40	MAZ16023000	BUTTON CLAMP SUPPORT, REAR		*		1
41	D1401M1YC0A	NEEDLE BAR				1
42	14147904	WIPER				1
43	13810908	MOVING PLATE LINK A				1
44	SS6090612TP	SCREW 9/64-40 L=6				2
45	MAZ16015000	BUTTON SUPPORT LINK				1
46	SD0640321TP	HINGE SCREW D=6.35 H=3.2				1
47	14149751	NEEDLE PLATE ASM. N				1

LK-1903-305:SHANK BUTTON CLAMP MECHANISM COMPONENTS

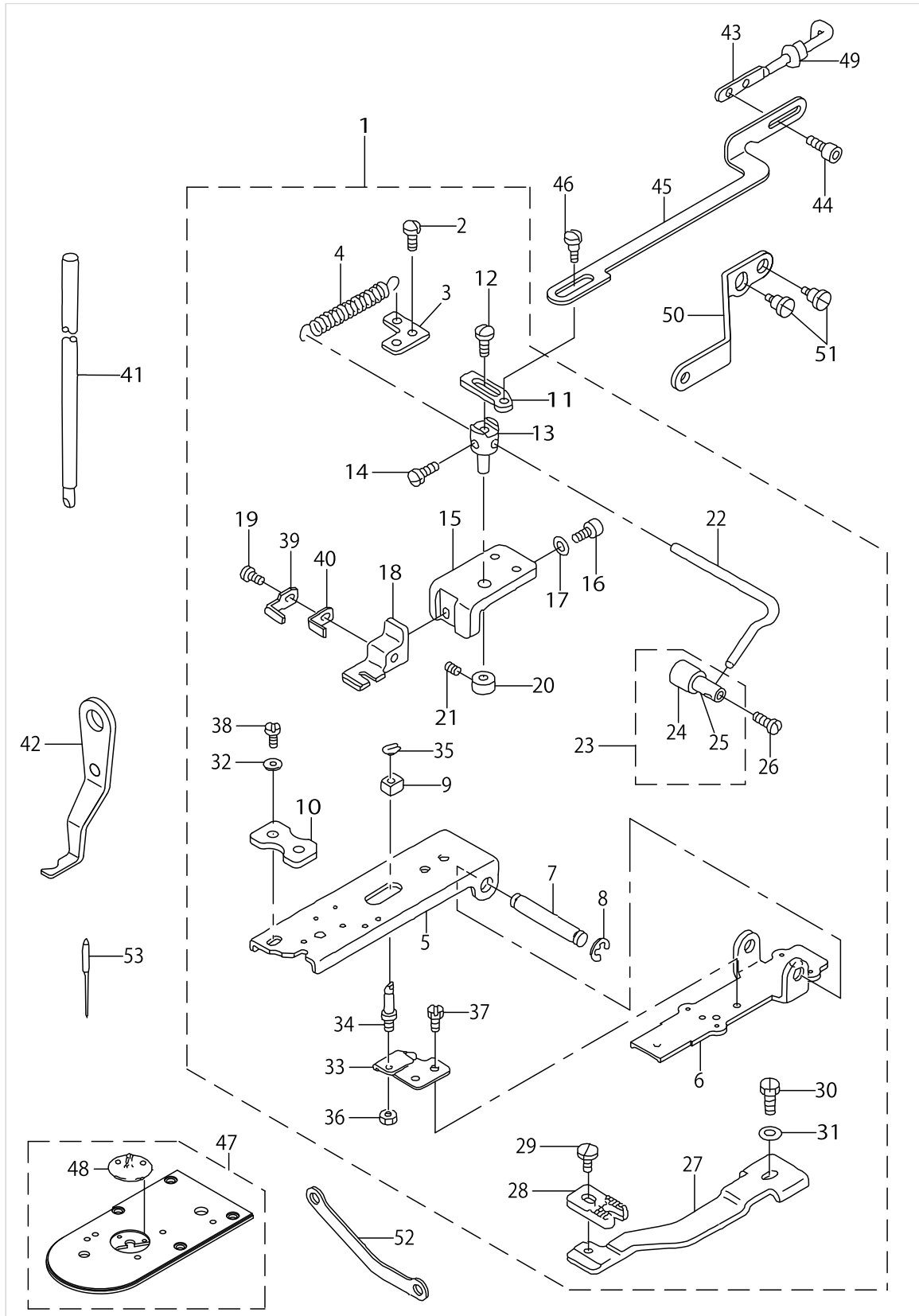

LK-1903-305:SHANK BUTTON CLAMP MECHANISM COMPONENTS

No.	Parts No.	Parts name	Remarks	Level	Cons	Qty
48	MAZ16021000	NEEDLE HOLE GUIDE		*		1
49	14148209	BUSHING				1
50	14148100	CONNECTING LINK				1
51	SD0700271TP	HINGE SCREW				2
52	13864400	WIPER LINK				1
53	MTQ300B1400	NEEDLE TQX3 #14				1

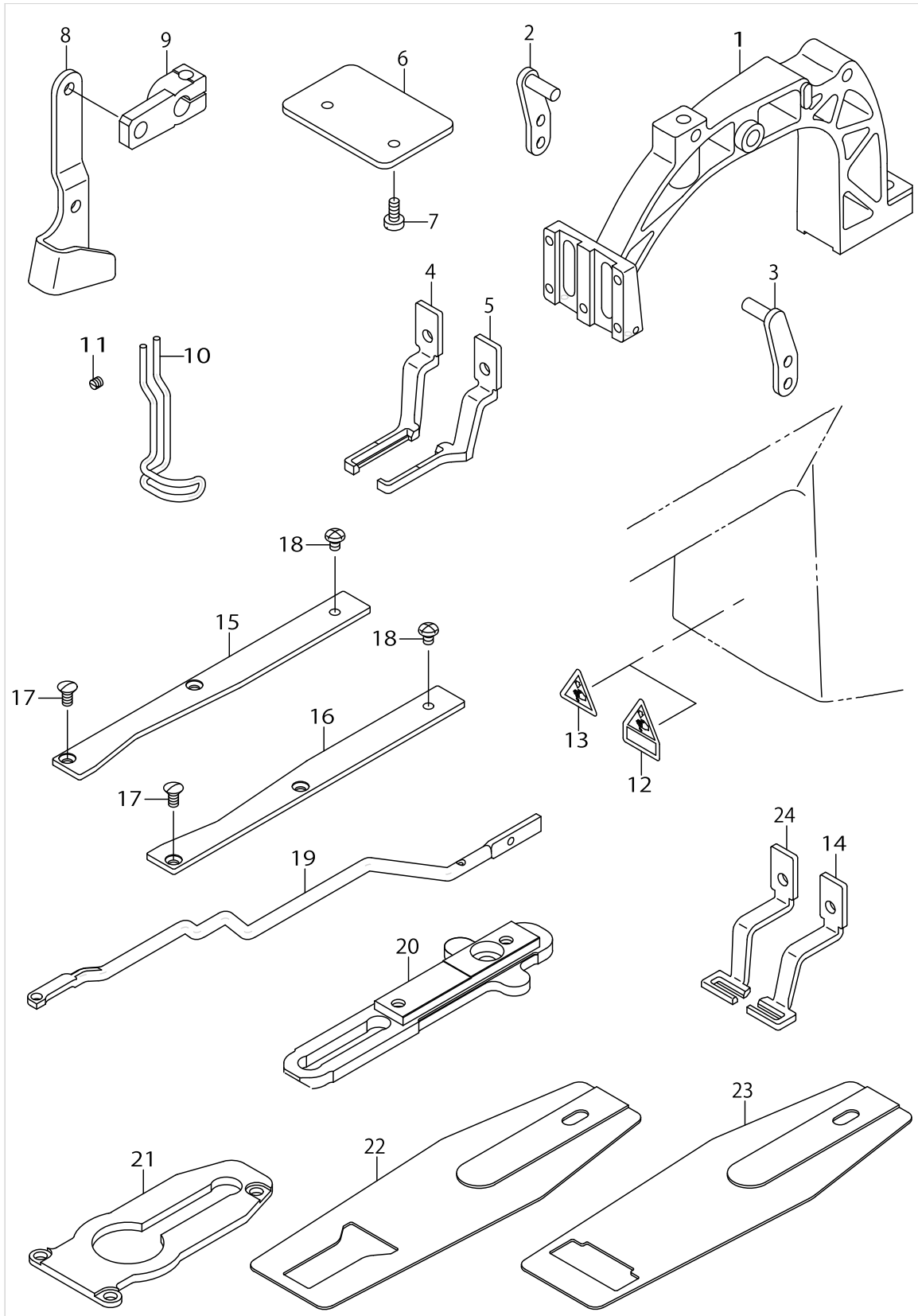

LK-1904

No.	Parts No.	Parts name	Remarks	Level	Cons	Qty
1	14136709	CLOTH FEED BASE				1
2	14137053	LEVER DRIVING PLATE COMPL.,L				1
3	14136956	LEVER DRIVING PLATE COMPL.,R				1
4	14137608	WORK CLAMP FOOT A ,LEFT				1
5	14137509	WORK CLAMP FOOT A ,RIGHT				1
6	14136808	SUPPORT PLATE				1
7	SS6111010TP	SCREW 11/64-40 L= 9.5				2
8	14135503	LOWERING FOOT				1
9	14135602	LOWERING ARM				1
10	14135305	FINGER GUARDE				1
11	SS8110422TP	SCREW 11/64-40 L=4				1
12	CM3002000B2	LABEL(25).				1
13	CM300200002	CAUTION LABEL(25)				1
14	14137806	CLOTH PRESSER FOOT B ,RIGHT	OPTIONAL PARTS			1
15	14136303	CLOTH FEED PRESSER PLATE ,L				1
16	14136204	CLOTH FEED PRESSER PLATE ,R				1
17	SS2110920TP	SCREW 11/64-40 L=8.5				4
18	SS4110615SP	SCREW 11/64-40 L=6				2
19	14135701	CONNECTING BAR				1
20	14136113	CLOTH FEED PLATE				1
21	14136006	CLOTH FEED SUPPORT PLATE				1
22	14137707	CLOTH PRESSER LOWER PLATE A				1
23	14138002	CLOTH PRESSER LOWER PLATE B	OPTIONAL PARTS			1
24	14137905	CLOTH PRESSER FOOT B ,LEFT	OPTIONAL PARTS			1

ACCESSORIES PARTS FOR LK-1900 SUB CLASSES

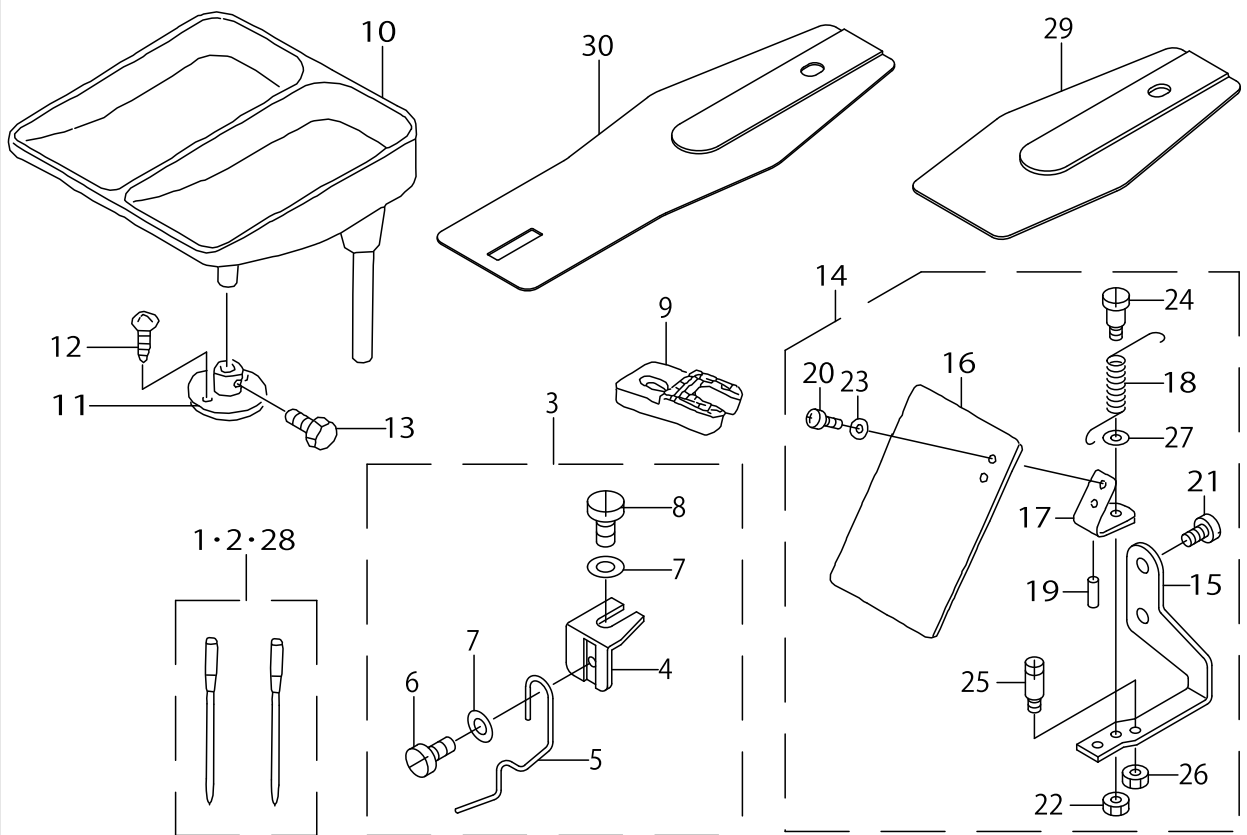

ACCESSORIES PARTS FOR LK-1900 SUB CLASSES

No.	Parts No.	Parts name	Remarks	Level	Cons	Qty
1	MDP170B1402	NEEDLE DPX17#14-2				1
2	MTQ300B1402	TQX3#14-2				1
3	14146757	BUTTON RISING BAR ASM.				1
4	14146807	INSTALLING BASE		*		1
5	14146708	BUTTON RISING BAR		*		1
6	SS6080340SP	SCREW 1/8-44 L=2.9		*		1
7	WP0370316SD	WASHER 3.7X8X0.3		*		2
8	SS9090813TP	SCREW 9/64-40 L=8		*		1
9	MAZ1600300B	FEED PLATE, B				1
10	17848458	BUTTON TRAY ASM.				1
11	17848508	BUTTON TRAY BASE				1
12	SK3412001SE	WOOD SCREW D=4.1 L=20				2
13	SS9151210TP	SCREW 15/64-28 L=11.8				1
14	13863758	SHAFT PLATE COMPL.				1
15	13863709	SAFETY PLATE INSTALLING PLATE		*		1
16	13889407	SAFETY PLATE		*		1
17	B3121980000	SAFETY PLATE INSTALLING PLATE		*		1
18	13863808	SAFETY PLATE BACK SPRING		*		1
19	PS0200062KH	SPRING PIN 2X6		*		1
20	SS4110715SP	SCREW 11/64-40 L=7		*		2
21	SS6110810TP	SCREW 11/64-40 L=8		*		2
22	NS6110310SP	NUT 11/64-40		*		1
23	WP0450801SD	WASHER 4.5X10X0.8		*		2
24	SD0601021SP	HINGE SCREW D=6 H=10.2		*		1
25	B1506352000	TENSION SPRING RACK B		*		1
26	NS6120310SP	NUT 3/16-28		*		1
27	WP0740516SP	WASHER 7.4X11.8X0.5		*		1
28	MDP170B1902	NEEDLE DPX17#19-2				1
29	14138101	PRESSER PLATE COVER				1
30	14116909	FEED PLATE I				1

HOW TO MAKE USE OF THIS PARTS LIST

1.Explanation of codes

1)"*"mark.....means this part is changed from the previous parts book.

As to the details of the change, refer to the "List for information of change".

2)"#01".....refer to "Note" explanation at bottom of page.

2.Codes on the "Qty" column

- Each numeral indicates the number of parts required.
- "0.1" and "2.5" indicate the length (in meters) of the respective parts.

3.Parentheses mean that the corresponding part is a subpart that constructs an assembly part.

4.Dotted lines on the Figures indicate assembly parts.

1."注記"欄の記号説明

1) "*"印.....前回のパーツブックに比較して今回変更された部品を意味します。

変更内容は、"変更情報リスト"を参照してください。

2) "#01".....ページ下の"注記"の説明を参照してください。

2.数量欄の数字は、個数を表し、0.1、2.5等の数値は、長さ（単位メートル）を表します。

3.数量欄の（ ）は、組部品を構成している子部品であることを意味します。

4.イラストページの-----枠は、組構成であることを意味します。

NUMERICAL INDEX OF PARTS

PART NO	PAGE	REF NO.	PART NO	PAGE	REF NO.	PART NO	PAGE	REF NO.
10004109	2	11	13518600	26	44~46	13545801	66	11·15~19
10087906	58	54	13518600	48	2·5·8·11-- 14·17	13546700	66	11·15~19
10087906	62	24				13547005	66	11·15~19
10087906	66	21	13518659	48	1·4·7·10-- 13·16	13547161	66	13·14
10087906	68	14	13518709	26	47~49	13548003	48	28~36·65 ~67
10502300	2	47	13518709	48	3·6·9·12-- 15·18	13548102	26	44~46
10523504	16	61				13548102	48	2·5·8·11-- 14·17
11018504	2	28	13518907	26	22	13548151	48	1·4·7·10-- 13·16
11043007	22	20	13529003	30	8	13548201	28	47~49
11043304	22	8	13529607	14	24	13548201	48	3·6·9·12-- 15·18
11072402	4	78	13533104	26	23·60	13548300	28	23·60
11155108	54	30	13540604	58	50	13548300	48	37·38
11155207	54	31	13540901	70	33	13548508	48	2·5·8·11-- 14·17
11158300	54	7	13540901	78	34	13548557	48	1·4·7·10-- 13·16
11158300	62	30	13541107	56	27	13548607	48	3·6·9·12-- 15·18
11158409	54	8	13541313	56	46	13548706	66	11·15~19
11158409	62	31	13541313	68	20	13551205	44	2
11158516	54	11	13541404	56	9	13551254	44	1
11158516	62	34	13541503	56	43	13554506	48	28~36·65 ~67
11158607	54	9	13541602	56	2	13554803	26	16
11158607	62	32	13542402	48	2·5·8·11-- 14·17	13554803	50	28~36·65 ~67
11159001	54	14				13556154	22	21~23
11159001	62	39	13542451	48	1·4·7·10-- 13·16	13561303	48	21
13502307	2	13				13561352	48	20
13506415	10	20	13542501	48	3·6·9·12-- 15·18	13561360	48	19
13507504	4	59	13542915	26	44~46	13561402	48	25
13508700	16	63	13542915	48	2·5·8·11-- 14·17	13561451	48	24
13508809	16	64				13562509	48	22
13508908	16	65	13542964	48	1·4·7·10-- 13·16	13562608	48	26
13509500	18	1	13543012	28	47~49	13571906	46	57
13509708	18	3				13571906	48	2·5·8·11-- 14·17
13509807	18	4	13543012	48	3·6·9·12-- 15·18	13571955	48	1·4·7·10-- 13·16
13509955	18	5	13543715	62	6	13572003	46	50
13513304	20	6	13543764	62	2	13572003	48	3·6·9·12-- 15·18
13515507	22	24	13543764	66	8	13573407	46	49
13515556	22	21~23	13543806	62	10	13573407	48	39
13516208	26	24	13543905	62	15	13574009	18	9
13517206	26	18	13544051	62	19			
13517404	26	20	13544465	62	3			
13517602	58	53	13544465	66	9			
13517602	70	2	13544614	62	5			
13517800	26	36	13544705	10	22			
13518105	26	39	13544705	62	17			
13518352	26	42	13545504	66	11·15~19			
13518501	26	40	13545660	66	13·14			

NUMERICAL INDEX OF PARTS

PART NO	PAGE	REF NO.	PART NO	PAGE	REF NO.	PART NO	PAGE	REF NO.
13786306	2	14	14103352	16	56~58	14108906	22	7
13786306	62	25	14103352	50	47~50	14108955	22	5
13786306	66	23	14103501	14	36	14109250	24	78
13810908	78	43	14103659	16	56~58	14109300	22	16
13811906	70	45	14103659	50	47~50	14109607	22	43~45
13812003	70	46	14103659	66	22	14109607	48	42~46
13812102	14	41	14103758	14	2·3	14109607	66	5
13812102	44	15	14103907	14	6	14109755	22	21~23
13816764	2	23	14104004	14	17	14110001	28	50
13816855	16	62	14104152	10	1	14110209	28	75
13817754	54	13	14104202	10	2	14110811	28	81
13817754	62	36	14104301	10	3	14111504	28	76
13860200	10	34	14104400	10	4	14111702	28	77
13860408	44	38	14104608	10	6	14111801	28	79
13860606	10	35	14104707	10	8	14112304	26	3
13863709	84	15	14104806	10	11	14112353	26	1
13863758	84	14	14105001	10	10	14112403	26	7
13863808	84	18	14105209	10	15	14112452	26	6
13864350	52	26	14105308	10	16	14112502	26	14
13864400	52	27	14105407	26	43	14113450	4	75
13864400	80	52	14105506	12	51	14113468	4	74
13864509	52	28	14105605	10	44	14113658	4	58
13864509	68	31	14105704	10	21	14113666	4	57
13889407	84	16	14105852	10	12	14114102	30	1
13943204	44	5	14105902	12	54	14114300	30	3
14100309	2	39	14106009	12	55	14114409	30	4
14100408	2	2	14106108	12	53	14114508	6	44
14100457	2	1	14106256	14	26	14114607	30	13
14100507	4	56	14106306	14	25	14114805	30	12·27
14100606	4	55	14106405	14	4	14114904	30	2
14100705	2	6	14106553	44	37	14115158	32	1
14100754	2	5	14106561	44	39	14115257	32	2
14100903	2	8	14106603	44	44	14115356	8	75
14101000	2	9	14106652	44	43	14115356	32	3
14101208	2	22	14106702	14	1	14115455	32	6
14102107	6	2	14107106	50	69	14115554	32	4
14102206	6	3	14107155	50	68	14115653	32	5
14102305	6	4	14107205	50	70	14116107	28	82
14102404	6	1	14107304	50	72	14116107	48	28~36·65 ~67
14102503	6	5	14107502	20	1	14116206	26	15
14102701	6	7	14107601	24	66	14116206	48	28~36·65 ~67
14102800	6	8	14107700	20	2	14116305	48	28~36·65 ~67
14103006	14	20	14108500	22	2	14116404	28	73·74
14103253	16	56~58	14108609	22	3			
14103253	48	47~50	14108807	22	6			

NUMERICAL INDEX OF PARTS

PART NO	PAGE	REF NO.	PART NO	PAGE	REF NO.	PART NO	PAGE	REF NO.
14116404	48	28~36·65 ~67	14136956	82	3	14146302	70	13
14116503	46	47·48	14137053	82	2	14146401	70	32
14116503	48	28~36·65 ~67	14137509	82	5	14146401	78	10
14116602	48	28~36·65 ~67	14137608	82	4	14146708	84	5
14116701	48	28~36·65 ~67	14137707	82	22	14146757	84	3
14116800	28	73·74	14137806	82	14	14146807	84	4
14116800	50	28~36·65 ~67	14137905	82	24	14146906	72	49
14116909	46	47·48	14138002	82	23	14147003	60	17
14116909	50	28~36·65 ~67	14138101	84	29	14147003	68	12
14116909	84	30	14140206	56	40	14147102	60	18
14117519	54	1	14140255	56	8	14147102	68	13
14118053	54	2	14140263	56	1	14147201	60	23
14118152	54	3	14140354	56	20	14147201	68	18
14118251	54	4	14140552	56	28	14147359	60	20
14118350	62	27	14140750	56	35	14147359	68	15
14120000	48	40	14140909	56	24	14147607	52	5
14120109	50	51~55	14141055	56	15	14147607	68	35
14120208	50	51~55	14141105	56	17	14147755	52	25
14120307	50	51~55	14141204	56	33	14147755	68	28
14120406	50	51~55	14141402	56	21	14147904	78	42
14120505	50	51~55	14141402	70	11	14148100	80	50
14121255	50	61	14141402	78	7	14148209	80	49
14121263	50	60	14141501	56	41	14148407	60	19
14121354	50	62	14141758	60	2	14148407	68	44
14121701	50	56·58	14141857	60	1	14148803	70	18
14121800	50	57·59	14141907	60	5	14148803	76	56
14121909	50	56·58	14142004	60	15	14148852	70	15
14122006	50	57·59	14142103	60	8	14148852	76	53
14122550	52	1	14142251	52	37	14148902	70	25
14122659	52	24	14142251	60	12	14148902	76	61
14135305	82	10	14142251	68	27	14148951	70	23
14135503	82	8	14143002	62	23	14148951	76	59
14135602	82	9	14143002	66	11·15~19	14149009	74	21
14135701	82	19	14144000	62	22	14149058	74	17
14136006	82	21	14144000	66	12	14149108	74	11
14136113	82	20	14145106	70	1	14149157	74	7
14136204	82	16	14145551	70	5~8	14149256	70	3
14136303	82	15	14145650	70	5~8	14149355	74	1
14136402	28	78	14145759	70	5~8	14149454	74	39
14136709	82	1	14145858	70	5~8	14149553	76	66
14136808	82	6	14146054	78	1	14149603	72	59
			14146104	70	10	14149751	78	47
			14146104	78	6	14149900	76	65
			14146203	70	9	17007402	54	10
			14146203	78	5	17007402	62	33

NUMERICAL INDEX OF PARTS

PART NO	PAGE	REF NO.	PART NO	PAGE	REF NO.	PART NO	PAGE	REF NO.
17845009	36	13	26501858	14	13	B1506352000	84	25
17848458	84	10	26501908	22	4	B1513210D00	10	23
17848508	84	11	40009859	52	7	B1515210D00	10	26
22537658	4	61	40009859	68	43	B152989000CA	4	67
22538151	4	62	40009860	52	8	B1649161000	24	48
22538300	4	63	40009860	68	21	B1652704000	22	15
22538409	4	64	40011409	14	2·3	B1657506E00	60	10
22814909	14	21	A1230500000A	6	47	B1802210D00	16	60
22924005	10	19	A3125002000	24	69	B1808980000	14	31
22930309	34	14	A321600100A	4	65	B1812980000	14	33
22930358	34	1	B1111210D00	2	15	B18129800A0	14	32
22930408	34	10	B1111232000	2	25	B1815980000	14	35·37
22930507	34	9	B1114581000	62	1	B1816280000	62	21
22930705	34	7	B1114581000	66	10	B1816980000	14	35·37
22930804	34	5	B1115210D00	2	10	B1817210DAD	50	47~50
22930903	34	4	B1115232000	24	72	B1818280000	14	38·39
22931000	34	3	B11152320A0	24	68	B1820210D00	14	10
22931109	34	2	B1116210D00	2	12	B1821210D00	14	12
22931208	34	15	B1116804000	22	47	B1822215P00	14	14
22931307	34	11	B1124280000	2	26	B18289800BB	14	42
22931406	34	8	B1125280000	2	27	B1836210D00	16	59
23630007	14	11·23	B1144210000	8	48	B185351200E	68	9
26204008	26	37	B1148555000	4	66	B1901210DA0	6	23
26204107	26	38	B1202280000	6	11	B1901210DC0	6	22
26211607	2	24	B1203280000	6	20	B1901280000	6	15
26217901	18	2	B1206210D00	6	12	B19012800B0	6	14
26222208	14	40	B1212210D00	8	49	B1903210000	6	25
26224105	26	41	B1223771000	6	13	B1903280000	6	16
26224204	48	37·38	B1223771000	22	46	B1903552000	6	28
26230706	30	11·26	B1229232000	18	6	B1904280000	6	31
26231100	14	5	B1230210D00	6	9	B1905541000	6	26
26234005	46	58	B1231210D00	6	10	B21012800A0	18	7·8
26500009	28	51	B1401280000	8	55·56	B210220500A	52	29
26500108	28	80	B1402280000	8	57	B210220500A	68	33
26500306	6	6	B1403280000	8	58	B2109280000	18	10
26500405	10	5	B1404280000	6	29	B23022050A0	20	9·10
26500504	24	73	B1405280000	8	59	B23022050A0	66	20
26500603	26	21	B1407210D00	6	24	B23022050A0	68	8
26500702	10	9	B1411552000	8	62	B2302280000	20	11
26500801	10	7	B14115520A0	8	61	B23022800A0	20	9·10
26500900	20	4	B1411804000	6	27	B2303280000	20	23
26501205	22	1	B1414232000	8	64	B2304210D00	20	3
26501304	20	5	B1414232000	26	17	B2312210D00	24	67
26501403	26	2	B1419026000	30	11·26	B2313280000	20	13
26501502	26	8	B1506352000	44	12	B2401210D00	22	17

NUMERICAL INDEX OF PARTS

PART NO	PAGE	REF NO.	PART NO	PAGE	REF NO.	PART NO	PAGE	REF NO.
B2406372000	78	25	B3119771000	20	19	BP600000000	30	20
B2408210D00	22	18	B3120125000	20	20	BT0500300EA	14	19
B2411210000	24	49	B3120372000	44	3	BT0600401EB	46	51
B24142800A0	22	25	B3121372000	44	4	CM200100001	36	14
B24152800A0	22	26	B3121980000	84	17	CM300100001	36	15
B2416280000	22	27	B3123352000	24	71	CM300100101	36	43
B2417280000	22	28	B3125012000	70	47	CM300200002	2	35
B2418280000	22	29	B3126012000	4	76	CM300200002	82	13
B24212800A0	22	30	B3126012000	20	21	CM3002000B2	2	34
B242328000A	22	31~35	B3126012000	24	70	CM3002000B2	82	12
B242328000B	22	31~35	B3129053000	20	17·18	CM300200101	2	30·31
B242328000C	22	31~35	B3132552000	20	22	CM3002001A1	2	30·31
B242328000D	22	31~35	B3205210000	4	68	CQ200000000	14	16
B242328000E	22	31~35	B3212761000	4	60	CQ200000000	30	15
B2424280000	22	36	B3213205000	8	72	CQ202000000	14	9·22
B2426280000	22	43~45	B3413552000	20	24	CQ202000000	30	19·25
B2426280000	48	42~46	B3413552000	62	18	CQ252200000	2	7
B242628000B	48	42~46	B3501210000	30	10	CQ252200000	30	21
B2509704000	26	19	B3506280000	30	12·27	CS0640811SP	78	20
B2539280000	62	7	B3508280000	30	16	CS079101ASH	10	29
B2545280000	20	7	B3509210D00	30	7	CS080081BSH	24	74
B2548280000	26	25	B3509220000	30	9·29	CS080081CSH	14	43
B2548280000	62	13	B3509280000	30	9·29	CS087101BSH	62	8
B2548372000	70	34	B3518280000	30	28	CS0950817SH	26	12
B2549280000	26	26	B8101210AAB	54	5	CS095081ASH	26	11
B2549280000	62	12	B8101210AAB	62	28	CS1000811SP	14	44
B2549372000	70	35	B8103980000	44	32	CS1201010SH	14	45
B2552372000	70	14	B8105210AAA	54	6	CS147121ASH	6	37
B2553372000	70	36	B8105210AAA	62	29	D1401L7VV00	8	55·56
B255728000A	26	27~31	B81085550A0	54	26	D1401L7VV00	66	1
B255728000B	26	27~31	B81085550A0	64	49	D1401L7VV00	68	6
B255728000C	26	27~31	B8133019000	44	33	D1401M1YC0A	78	41
B255728000D	26	27~31	B8153771000	54	15	D1405L7AM00	8	60
B255728000E	26	27~31	B8153771000	62	40	D1405L7AM00	66	2
B2560372000	70	37	B8202205000	44	16	D1405M7WF00	68	1
B2583210D00	40	28	B9101552000	44	17	D1818282N00	14	38·39
B2617771000	24	77	B9109555000	44	18~20	D1818282N00	66	7
B2619372000	68	10	B9110012000	44	18~20	D1901L7VVB0	68	3
B2707761000	2	16	B9111012000	44	18~20	D1904L7VV00	68	4
B302745000B	60	13	B9113012000	44	21	D1906L7VV00	68	5
B3107804000	20	14	B9121012000	44	22	D2101L7AMA0	18	7·8
B3112761000	20	15·16	B91212200A0	44	26	D2101L7AMA0	66	6
B3114232000	20	17·18	B9140372000	44	23~25	D2426282C00	22	43~45
B3114771000	2	29	B9141372000	44	23~25	D2426282C00	48	42~46
B3117352000	56	7	BP300000100	30	19·25	D2426MMCK00	48	42~46

NUMERICAL INDEX OF PARTS

PART NO	PAGE	REF NO.	PART NO	PAGE	REF NO.	PART NO	PAGE	REF NO.
D2502232D00	10	24	HD00057000A	10	17	M85205800A0	42	18
D2511232D00	56	19	HD00057000A	28	54	M85205900A0	40	22
D2512232D00	56	18	HD002230000	6	41	M85205900A0	42	11
D2515232D00	56	25	HD002230000	28	53	M85405900A0	36	10
D2520232D00	56	30	HD002230000	40	26	M85975900A0	42	24
D2521232D00	56	31	HF001301000	40	17~19	M85985900A0	32	13
D2527232D00	56	6	HF0041080P0	40	17~19	M85995900A0	40	15·16
D2527232D00	72	48	HK016510120	44	45	M8599590AA0	40	15·16
D2528232D00	56	5	HK016540000	44	46	M8601590AA0	36	1
D2529232D00	56	4	HK026650080	36	19	M86045900A0	36	3·4
D2545232D0A	56	12~14	HK034610020	22	13	M8604590AA0	36	3·4
D2545232D0B	56	12~14	HK03461004A	60	3·4	M86065900A0	40	3
D2545232D0C	56	12~14	HK034640000	22	14	M8612590AA0	38	49
D2548232D00	70	38	HK034640000	60	3·4	M8901590AA0A	36	11·12
D2548232D00	78	35	HK054250040	36	20	M8901590BA0A	36	11·12
D2587L8WB00	24	51	HM000860010	36	21	M89105900A0	36	2
D2588L8WB00	24	53	HX00056000B	36	22	M90015900A0	42	1
D3112L4BB00	20	15·16	HX001230000	40	27	M90025800A0	42	9
D3130M1YC00	70	42	HX00123000B	36	41	M90035900A0	42	2
D7133555B00	4	77	HX00123000C	52	34	M90045900A0	42	3
D8113555B00	54	16	HX00123000C	68	25	M90085800A0	42	4
D8113555B00	62	41	HX00147000C	36	23	M90115900A0	40	25
D8204555D00	54	32	HX00150000G	32	9	M90125900A0	40	35
E8523304000	40	17~19	HX00150000H	32	12	M90125900A0	42	19
E9567319000	36	16	HX00150000L	32	11	M90135900A0	40	33
E9607603000	40	37	HX004070000	36	24	M90135900A0	42	21
E9609603000	36	17	HX004100000	36	25	M90175800A0	42	12~ 14·22·23
EA9500B0100	30	22	M1001590000	36	5	M90205800A0	42	5·6
EA9500B0100	32	7	M10025800A0	36	6	M9020580AA0	42	5·6
EA9500B0100	36	18	M1003590000	36	7	M90215800A0	42	15
EA9500B0200	46	60	M1010590000	40	6	M90225900A0	42	7·8
EA9502B0500	40	11	M1011590000	40	7	M90235900A0	42	7·8
G1216870000	6	38	M1012590000	40	8	M90245800A0	42	12~ 14·22·23
G6705152U0A	36	44	M1030590000	40	23	M90285800A0	42	12~ 14·22·23
GAF01007000	8	50	M1031590000	40	24	M90315900A0	42	10
GCT02906000	44	23~25	M300258000B	36	8·9	M90345800A0	42	12~ 14·22·23
GPF060600A0	54	18	M300259000A	40	4·5	M90355800A0	42	12~ 14·22·23
GPF060600A0	62	37	M300259000B	40	4·5	M90415900A0	32	15
GPF06080000	54	17	M3003580000	40	20·21	M90425900A0	32	16
GPF06080000	62	38	M300359000A	36	8·9	M90435900A0	32	17
GPK570010B0	40	36	M300451100A	40	20·21	M90445900A0	32	20
GPK570010B0	42	20	M8002430000	2	4	M90475900A0	32	14
HA00303000A	42	16·17	M8510590AA0	40	1·2			
HA004250000	36	26	M8510590BA0	40	1·2			
HA004250000	42	16·17	M85205800A0	40	34			

NUMERICAL INDEX OF PARTS

PART NO	PAGE	REF NO.	PART NO	PAGE	REF NO.	PART NO	PAGE	REF NO.
M90515900A0	42	25	MAZ158070AB	74	45·46	NM6050001SP	24	57
M90525900A0	42	26	MAZ158070BA	74	41·42	NM6050001SP	44	41
M964051000A	32	18	MAZ158070BB	74	41·42	NM6060001SC	2	20
MAO11532000	46	59	MAZ158080AA	76	49·50	NM6060001SC	44	35
MAZ15501000	70	4	MAZ158080AB	76	49·50	NM6060001SE	38	48
MAZ15502000	72	60	MAZ158080BA	74	47·48	NM6080721SE	54	25
MAZ15507000	70	16	MAZ158080BB	76	47·48	NM6080721SE	64	48
MAZ15507000	74	54	MAZ15809000	74	43	NM6120001SE	54	27
MAZ15507000	76	54	MAZ15810000	76	52	NM6120001SE	64	50
MAZ155070A0	74	14	MAZ16002000	78	27	NM6160511SE	34	18
MAZ155070B0	74	13	MAZ1600300A	78	28	NM6540023SB	12	48
MAZ15508000	70	24	MAZ1600300B	84	9	NS6090310SP	2	33
MAZ15508000	74	60	MAZ16004000	78	15	NS6110310SP	4	79
MAZ15508000	76	60	MAZ16005000	78	18	NS6110310SP	44	9
MAZ155080A0	74	4	MAZ16009000	78	24	NS6110310SP	52	31
MAZ155080B0	74	3	MAZ160090A0	78	23	NS6110310SP	68	23
MAZ15509000	70	17	MAZ16010000	78	22	NS6110310SP	84	22
MAZ15509000	74	55	MAZ16011000	78	13	NS6110420SP	24	61
MAZ15509000	76	55	MAZ16012000	78	3	NS6110530SP	56	16
MAZ15510000	70	27	MAZ16013000	78	4	NS6120310SP	20	33
MAZ15510000	74	63	MAZ16014000	78	11	NS6120310SP	24	63
MAZ15510000	76	63	MAZ16015000	78	45	NS6120310SP	44	13
MAZ15513000	70	29	MAZ16021000	80	48	NS6120310SP	52	21
MAZ15514000	70	30	MAZ16022000	78	39	NS6120310SP	68	41
MAZ15514000	78	33	MAZ16023000	78	40	NS6120310SP	84	26
MAZ15515000	70	31	MDP170B1400	68	7	NS6120480SP	56	34
MAZ15515000	78	9	MDP170B1402	84	1·2·28	NS6150310SP	10	25
MAZ15516000	72	55	MDP170B1900	8	65~68	NS6150310SP	24	75
MAZ15601000	74	2	MDP170B1900	66	4	NS6150310SP	70	39
MAZ15602000	74	23	MDP170B1902	44	27~30	NS6150310SP	78	36
MAZ15701000	74	40	MDP170B1902	84	1·2·28	NS6660410SH	22	9
MAZ15702000	74	24	MDP500B1100	8	65~68	NS6660430SP	14	47
MAZ157070AA	74	27·28	MDP500B1102	44	27~30	NS6660430SP	22	11
MAZ157070AB	74	27·28	MDP500B1400	8	65~68	PA2502007A0	60	21
MAZ157070BA	74	25·26	MDP500B1402	44	27~30	PA2502007A0	68	16
MAZ157070BB	74	25·26	MDP500B1600	8	65~68	PA2502507A0	10	13
MAZ157080AA	74	34·35	MDP500B1602	44	27~30	PB000010000	46	52
MAZ157080AB	74	34·35	MTQ300B1400	80	53	PD02010000B	58	51
MAZ157080BA	74	32·33	MTQ300B1402	84	1·2·28	PJ032526001	46	53
MAZ157080BB	74	32·33	NM3034000SF	36	27	PJ304060502	10	14
MAZ15709000	74	29	NM6030003SC	36	28	PJ304060502	60	22
MAZ15710000	74	36	NM6040000SN	22	10	PJ304060502	68	17
MAZ15715000	74	38	NM6040003SC	52	22	PJ309005201	46	54
MAZ15801000	76	67	NM6040003SC	68	29	PS0200062KH	44	6
MAZ158070AA	74	45·46	NM6050001SE	34	17	PS0200062KH	84	19

NUMERICAL INDEX OF PARTS

PART NO	PAGE	REF NO.	PART NO	PAGE	REF NO.	PART NO	PAGE	REF NO.
PS0400142KH	8	51	SD0790311TP	24	81	SM6040602TP	10	38
RC0410415KP	60	14	SD0790601SP	10	28	SM6040602TP	24	76
RC0470611KP	18	11	SD0791271SP	68	11	SM6051202TP	44	40
RC0560711KP	4	69	SD0800331TH	40	29	SM6061202TP	56	38
RE0300000K0	14	15	SD0800341SP	10	30-31	SM6061202TP	72	52
RE0500000K0	4	70	SD0800342TP	10	46	SM6061602TP	10	45
RE0500000K0	24	64	SD0801021TP	16	49	SM6061602TP	60	24
RE0600000K0	12	49	SD1000401SP	10	32	SM6061602TP	68	19
RE0700000K0	26	32	SD1100301TP	24	50	SM6061610SC	34	6
RE0700000K0	56	22	SD1201501SP	58	48	SM6061802TP	10	37
RE0700000K0	70	12	SK3311601SE	44	56	SM6061802TP	28	61
RE0700000K0	78	8	SK3311601SE	46	56	SM6061802TP	56	47
RE0900000K0	16	48	SK3311601SE	54	33	SM6067552TP	2	18
RE1500000K0	50	71	SK3382001SE	2	21	SM6067552TP	44	34
RO044240100	60	16	SK3382001SE	32	19	SM8053002TP	22	19
RO048190100	12	56	SK3382001SE	40	13	SM8060612TP	6	39
RO069180100	26	10	SK3412001SE	84	12	SM8060612TP	26	9
RO092270200	4	71	SK3482001SE	36	42	SM8061612TP	6	40
RO154240100	8	54	SK3482001SE	40	14	SM9061203SE	54	19
SB30800100A	14	27~30	SK3482001SE	46	55	SM9061203SE	62	42
SB30800100B	14	27~30	SK3513201SE	54	34	SM9061403CP	56	37
SB30800100C	14	27~30	SL4030681SC	60	9	SM9082023SE	54	22
SB30800100D	14	27~30	SL4030681SF	36	29	SM9082023SE	62	45
SD0500091TP	22	37	SL4030881SC	60	6	SS1060210TP	22	38
SD0500803TP	24	79	SL4030881SF	40	9	SS1110640TP	24	52
SD0530221SP	18	12	SL4030891SC	36	30	SS1110640TP	48	27
SD0530221SP	20	25	SL4031291SC	10	33	SS1110640TP	56	29
SD0550181SP	70	43	SL4031291SC	28	56	SS2060310SP	70	28
SD0550271TP	56	32	SL4040681SC	36	36	SS2060310SP	74	64
SD0550303TP	70	21	SL4040881SF	36	31	SS2060310SP	76	64
SD0600181TP	52	30	SL4041081SF	36	33	SS2060510SP	8	69
SD0600181TP	68	42	SL4041091SC	36	38	SS2110920TP	28	63
SD0601021SP	44	11	SL4041291SC	6	42	SS2110920TP	82	17
SD0601021SP	84	24	SL4041291SC	28	55	SS2110930SP	26	33
SD0640211SP	18	13	SL4041291SC	40	31	SS2110930SP	62	4
SD0640261SP	52	19	SL4051091SC	36	39	SS4090415SP	14	7
SD0640261SP	68	39	SL9082091SE	54	12	SS4090515SP	20	30
SD0640321TP	78	46	SL9082091SE	62	35	SS4090715SP	2	45
SD0640391TP	10	27	SM1033501SC	36	40	SS4110515SP	28	66
SD0640391TP	20	27	SM3061052TP	28	64	SS4110515SP	30	5
SD0640391TP	70	22	SM3065052TC	36	45	SS4110515SP	32	8
SD0640482SP	20	28	SM4031851SR	36	34	SS4110615SP	52	35
SD0650305TP	24	80	SM4040601SC	40	30	SS4110615SP	68	26
SD0700271TP	80	51	SM4051405SE	34	12	SS4110615SP	82	18
SD0720321TP	20	26	SM4060801SE	6	43	SS4110715SP	28	58

NUMERICAL INDEX OF PARTS

PART NO	PAGE	REF NO.	PART NO	PAGE	REF NO.	PART NO	PAGE	REF NO.
SS4110715SP	30	23	SS6681712TP	6	33	SS8110520TP	14	46
SS4110715SP	32	10	SS7060310SP	52	9	SS8111610SP	8	73
SS4110715SP	44	8	SS7060310SP	68	22	SS8150510TP	26	34
SS4110715SP	84	20	SS7080510TP	8	70-71	SS8150822TP	10	39
SS4111015SP	2	38	SS7080510TP	66	3	SS8150822TP	16	54
SS4150715SP	2	41	SS7080510TP	68	2	SS8150822TP	24	59
SS4150715SP	12	50	SS7090410SP	22	40	SS8150822TP	62	20
SS4150915SP	62	26	SS7090410SP	70	26	SS8660530TP	6	34
SS4150915SP	66	24	SS7090410SP	74	62	SS8660610TP	6	35
SS4151215SP	2	44	SS7090410SP	76	62	SS8660612TP	28	52
SS4151215SP	10	47	SS7090510SP	78	19	SS8661012TP	24	60
SS4151215SP	60	11	SS7090610SP	56	42	SS9090813TP	84	8
SS6060410TP	14	50	SS7090850SP	58	52	SS9110460CP	56	44
SS6060410TP	16	50	SS7110710SP	50	64	SS9110460CP	70	40
SS6080340SP	8	70-71	SS7110730SP	2	17	SS9110460CP	78	37
SS6080340SP	84	6	SS7110740TP	22	54	SS9110543CP	56	36
SS6090612TP	78	44	SS7110740TP	24	54	SS9110543CP	72	51
SS6090670TP	8	63	SS7110740TP	26	35	SS9110920CP	56	23
SS6092120SP	30	24	SS7110740TP	62	14	SS9111010SP	78	30
SS6110420TP	28	67	SS7110740TP	78	26	SS9151120CP	56	10
SS6110430TP	22	39	SS7110840SP	2	46	SS9151120CP	72	57
SS6110480SP	16	51	SS7110840SP	6	46	SS9151210TP	84	13
SS6110480SP	78	29	SS7110840SP	10	52	SS9621413SP	70	41
SS6110610TP	2	43	SS7110840SP	12	52	SS9621413SP	78	38
SS6110610TP	10	18	SS7110840SP	16	52	SS9661230CP	8	74
SS6110610TP	28	65	SS7110840SP	18	14	ST40316110R	40	10
SS6110810TP	20	29	SS7110840SP	24	55	SV4031006SR	40	12
SS6110810TP	52	36	SS7110840SP	56	26	TA0550604R0	60	7
SS6110810TP	84	21	SS7110840SP	72	50	TA0750704R0	4	48
SS6111010TP	52	2	SS7111110TP	16	55	TA1050504R0	4	54
SS6111010TP	68	32	SS7111120SP	52	4	TA1250406R0	4	51
SS6111010TP	82	7	SS7111120SP	68	34	TA1250705R0	52	33
SS6111052TP	78	16	SS7111120TP	20	31	TA1250705R0	68	24
SS6111140SP	2	73	SS7111120TP	52	32	TA1470704R0	4	52
SS6111140SP	4	73	SS7111410TP	6	45	TA2100904R0	4	53
SS6111140SP	28	59	SS7151120SP	6	36	TA2100904R0	72	56
SS6120930SP	24	56	SS7151210SP	62	11	WP0280500SC	68	36
SS6120930SP	30	6	SS8080310TP	28	70	WP0370316SD	84	7
SS6120940SP	62	16	SS8090610SP	20	12	WP0430801SC	40	32
SS6121212TP	14	34	SS8110310SP	8	53	WP0450000SD	22	12
SS6151142TP	28	68	SS8110310SP	48	41	WP0450801SD	12	57
SS6151220SP	16	53	SS8110410TP	26	13	WP0450801SD	44	10
SS6151220SP	28	69	SS8110410TP	78	21	WP0450801SD	52	17
SS6151412TP	6	32	SS8110422TP	4	72	WP0450801SD	68	37
SS6151812TP	20	32	SS8110422TP	82	11	WP0450801SD	84	23

NUMERICAL INDEX OF PARTS

PART NO	PAGE	REF NO.	PART NO	PAGE	REF NO.
WP0450846SP	22	42	WZ0640200KP	68	40
WP0482086SD	20	8			
WP0482086SD	78	31			
WP0501016SD	24	65			
WP0501016SD	56	45			
WP0501016SD	70	53			
WP0501016SD	72	53			
WP0501016SD	78	32			
WP0553216SD	24	62			
WP0560860SE	10	43			
WP0612516SD	56	39			
WP0612516SD	72	58			
WP0621016SD	28	72			
WP0651001SC	36	46			
WP0651056SD	20	34			
WP0651056SH	58	49			
WP0651646SC	2	19			
WP0651646SC	44	36			
WP0671016SE	54	20			
WP0671016SE	62	43			
WP0740516SP	44	14			
WP0740516SP	84	27			
WP0871602SE	54	23			
WP0871602SE	62	46			
WP0952616SD	14	8			
WP1302501SE	54	28			
WP1302501SE	64	51			
WP1702600S0	34	19			
WS0310702KS	36	35			
WS0410002KS	52	23			
WS0410002KS	68	30			
WS0451040KP	50	63			
WS0451040KP	52	18			
WS0451040KP	68	38			
WS0510002KN	34	16			
WS0510002KN	44	42			
WS0610002KN	8	76			
WS0610002KN	36	47			
WS0621210KR	54	21			
WS0621210KR	62	44			
WS0861410KR	54	24			
WS0861410KR	62	47			
WS1253010KN	54	29			
WS1253010KN	64	52			
WZ0640200KP	52	20			