

CONSEW®

CONSOLIDATED SEWING MACHINE CORPORATION

MODEL

199R-1A

199R-2A

199R-3A

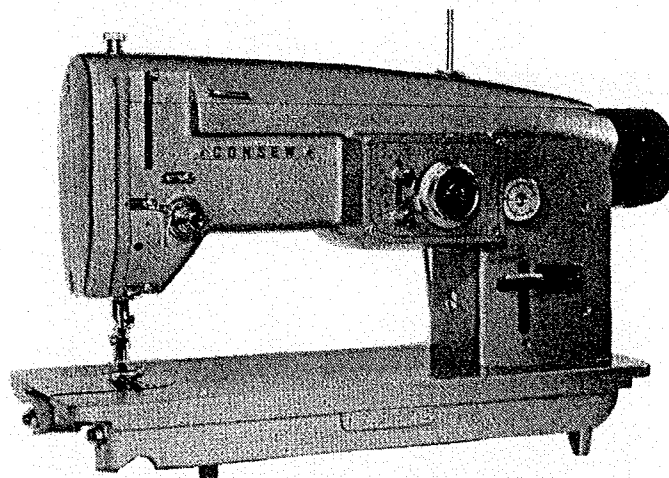

INSTRUCTION MANUAL

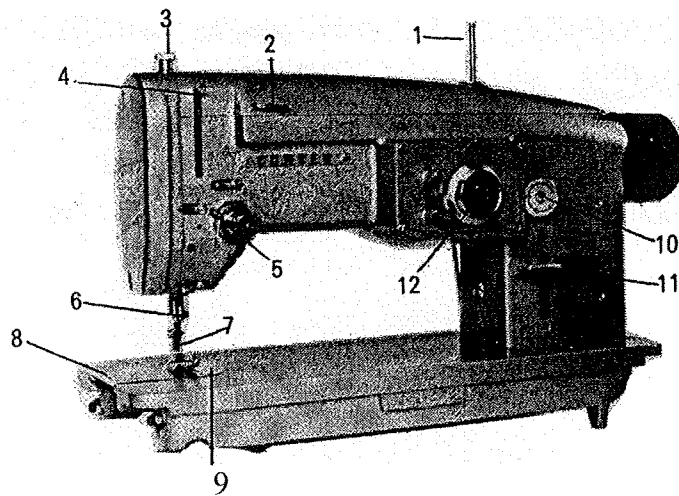

199R

CONSEW MODEL 199R IS A ZIGZAG AND STRAIGHT STITCH SEWING MACHINE WITH A ROTARY HOOK. THAT PRODUCES A LOCKSTITCH.

MAIN PARTS:

- | | | |
|-----------------------|-----------------------------|--|
| 1. SPOOL PIN | 6. NEEDLE BAR | 11. FEED DIRECTION LEVER (FOR TACKING) |
| 2. THREAD GUIDE | 7. PRESSER FOOT | 12. ZIGZAG WIDTH |
| 3. PRESSURE REGULATOR | 8. COVER OR SLIDE PLATE | |
| 4. TAKE UP LEVER | 9. NEEDLE PLATE | |
| 5. TENSION REGULATOR | 10. STITCH LENGTH REGULATOR | |

NEEDLES

MODEL 199R USES STANDARD NEEDLE STYLE 16 x 231 UP TO SIZE 19 OR STYLE 16 x 95 IN ALL SIZES.

THREAD

LEFT TWIST THREAD SHOULD BE USED IN THE NEEDLE.

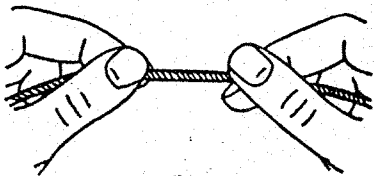

fig 2

EITHER RIGHT OR LEFT TWIST THREAD CAN BE USED IN THE BOBBIN.

HOW TO DETERMINE THE TWIST OF THE THREAD: HOLD THE THREAD AS SHOWN ABOVE; TWIST IT BETWEEN THE THUMB AND FORE-FINGER OF YOUR HANDS. IF IT IS LEFT TWIST THE STRANDS WILL WIND TIGHTER. IF RIGHT TWIST; THE STRANDS WILL UNRAVEL.

REMOVING THE BOBBIN CASE;

RAISE THE NEEDLE BAR TO ITS HIGHEST POINT BY TURNING THE HAND WHEEL TOWARD YOU. OPEN THE SLIDE PLATE BY SLIDING IT TO THE LEFT AND WITH THE LEFT THUMB AND FOREFINGER PLACED UNDER THE BED, OPEN THE HINGED LATCH (A) AT THE FRONT OF THE BOBBIN CASE AND USING THIS LATCH REMOVE THE BOBBIN CASE FROM THE SEWING HOOK. THE BOBBIN WILL FALL OUT OF THE BOBBIN CASE INTO YOUR HAND, THEN CLOSE THE BOBBIN CASE LATCH (A).

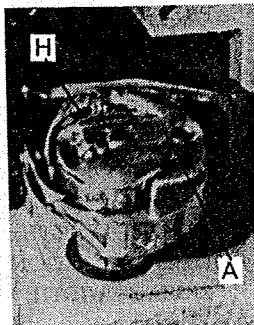

Fig. 3

WINDING THE BOBBIN;

1. PLACE THE BOBBIN (3) ON SPINDLE WINDER
2. PASS THE THREAD THROUGH THE HOLE (4) OF THE BOBBIN WINDER THREAD GUIDE AND THROUGH THE TENSION DISCS (5) FROM THE REAR.
3. PULL THE END OF THE THREAD AND WIND IT AROUND THE EMPTY BOBBIN SEVEN OR EIGHT TIMES FROM THE BOTTOM UP, AS SHOWN BY THE ARROW IN FIG. 4.
4. PUSH THE BOBBIN WINDER LEVER (1) DOWN UNTIL THE BOBBIN WINDER WHEEL (2) PRESSES AGAINST THE DRIVE BELT.
5. START THE MACHINE AND THE THREAD WILL BEGIN WINDING ON THE BOBBIN. WHEN THE BOBBIN IS FULL, IT WILL RELEASE AUTOMATICALLY AND STOP.
6. CUT THE THREAD AND REMOVE THE BOBBIN FROM THE SPINDLE.
7. YOU CAN ADJUST THE QUANTITY OF THREAD TO BE WOUND ON THE BOBBIN BY ADJUSTING THE SCREW (7) WHICH CONTROLS THE LATCH (6).
8. IF THE THREAD DOES NOT WIND EVENLY ON THE BOBBIN. ADJUST THE POSITION OF THE BOBBIN WINDER THREAD GUIDE (4) BY MOVING IT TO THE RIGHT OR LEFT AFTER LOOSENING THE SCREW.
9. LOOSEN THE TENSION FOR FINE THREAD BY TURNING THE NUT IN A COUNTERCLOCKWISE DIRECTION.

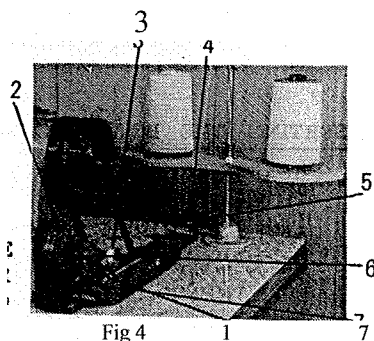

Fig 4

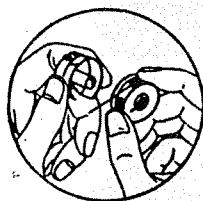

Fig. 5-A

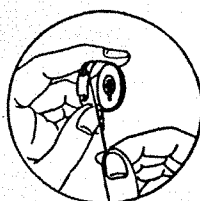

Fig. 5-B

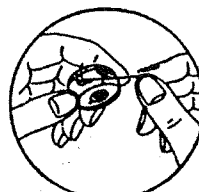

Fig. 5-C

THREADING THE BOBBIN CASE

1. HOLD THE BOBBIN CASE BETWEEN THE LEFT THUMB AND FOREFINGER AS SHOWN ABOVE. WITH ABOUT 2 INCHES OF THREAD TRAILING, HOLD THE BOBBIN BETWEEN THE THUMB AND FIRST TWO FINGERS OF THE RIGHT HAND, AS SHOWN IN FIG. 5A.
2. INSERT THE BOBBIN INTO BOBBIN CASE AND PULL THE TRAILING THREAD INTO THE SLOT, DOWN AND TO THE LEFT, UNTIL IT ENTERS THE GROOVED EYE UNDER THE TENSION SPRING FIG. 5B, 5C.
3. LEAD THREAD END THROUGH GUIDE HOLDER (H) FIG. 6, LOCATED AT FRONT OF BOBBIN CASE ABOVE THE HINGED LATCH.

INSERTING THE BOBBIN CASE

1. RAISE THE NEEDLE BAR TO ITS HIGHEST POINT BY TURNING THE HAND WHEEL TOWARD YOU.
 2. AFTER SLIDING OUT THE SLIDE PLATE, HOLD THE BOBBIN CASE LATCH WITH LEFT THUMB AND FORE FINGER TO PREVENT THE BOBBIN FROM FALLING OUT.
 3. PRESS THE BOBBIN CASE ONTO POST (P) UNTIL THE PROTRUDING FINGER (C) ENTERS THE NOTCH (B) OF THE HOOK, AND THEN CLOSE THE LATCH.
- NOTE; BE SURE THAT THE PROTRUDING FINGER ENTERS THE NOTCH PROPERLY AND IN THE CORRECT POSITION.

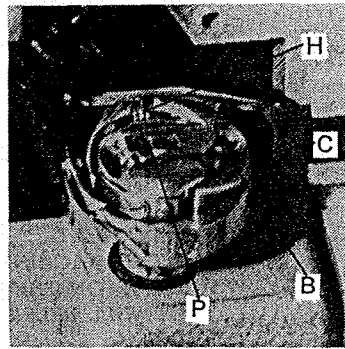

Fig. 6

THREADING THE MACHINE (FIG. 7)

1. RAISE THE THREAD TAKE-UP LEVER (7) TO ITS HIGHEST POSITION BY TURNING THE HAND WHEEL TOWARD YOU.
2. LEAD THE THREAD THROUGH THE HOLE (1) OF THE SPOOL PIN AND THE THREE HOLED THREAD GUIDE (2).
3. RUN THE THREAD BENEATH AND AROUND THE TENSION DISCS (3) FROM RIGHT TO LEFT.
4. BRING THE THREAD OVER THE LOOP OF THE CHECK SPRING (4) AND DOWN AGAIN UNDER THE RETAINING HOOK (5), FROM RIGHT TO LEFT.
6. NOW RUN THE THREAD DOWN THROUGH THE THREAD GUIDES, (6) & (8).
7. LEAD THE THREAD THROUGH THE NEEDLE BAR THREAD GUIDE (9).
8. NOW RUN THE END OF THE THREAD THROUGH THE EYE OF THE NEEDLE FROM FRONT TO BACK, DRAWING IT OUT ABOUT 2 INCHES.

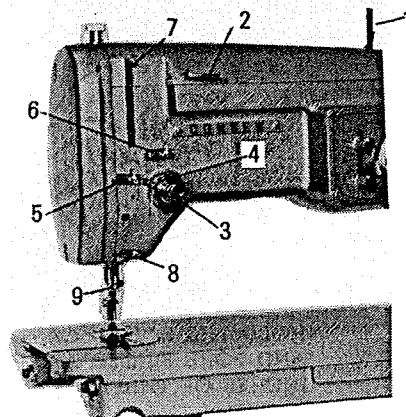

Fig. 7

PREPARING TO SEW (FIG.8)

1. THREADING THE MACHINE.
2. HOLDING THE LOOSE END OF THE NEEDLE THREAD IN YOUR LEFT HAND, TURN THE HAND WHEEL TOWARD YOU WITH YOUR RIGHT HAND UNTIL THE NEEDLE MOVES DOWN AND UP AGAIN TO ITS HIGHEST POINT.
3. PULL THE NEEDLE THREAD GENTLY AND THE BOBBIN THREAD WILL COME UP WITH IT THROUGH THE HOLE IN THE THROAT PLATE.
4. PLACE BOTH ENDS OF THREAD BENEATH AND IN BACK OF THE PRESSER FOOT.
5. WITH THE NEEDLE RAISED, PLACE THE MATERIAL TO BE SEWN BENEATH THE PRESSER FOOT AND LOWER THE PRESSER FOOT LEVER AS FAR AS IT WILL GO.
6. START SEWING.

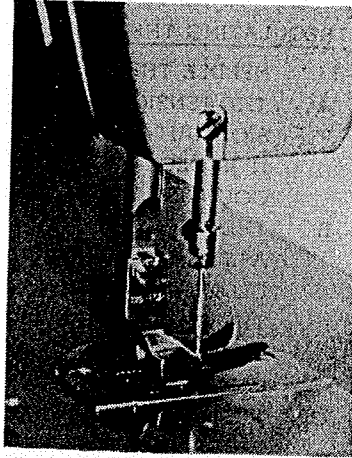

Fig. 8



Fig. 9-A



Fig. 9-B



Fig. 9-C

TENSION

FOR PERFECT STITCHING THE TENSION OF THE UPPER AND LOWER THREADS SHOULD BE BALANCED AND JUST TIGHT ENOUGH TO LOCK BOTH THREADS IN THE CENTER OF THE MATERIAL (FIG. 9-A). IF THE TENSION OF THE NEEDLE THREAD IS TOO TIGHT, OR IF THAT OF THE BOBBIN THREAD IS TOO LOOSE, THE NEEDLE THREAD WILL LIE STRAIGHT ALONG THE UPPER SURFACE OF THE MATERIAL, MAKING AN IMPERFECT STITCH (FIG. 9-B). IF THE TENSION ON THE BOBBIN THREAD IS TOO TIGHT, OR IT IS TOO LOOSE, ON THE NEEDLE THREAD, THE BOBBIN THREAD WILL LIE STRAIGHT ALONG THE UNDER SIDE OF THE MATERIAL, MAKING AN IMPERFECT STITCH (FIG. 9-C).

REGULATING THE TENSION

NEEDLE THREAD TENSION (FIG. 9-D)

THE TENSION IS INCREASED AS THE TENSION NUT (A) IS TURNED CLOCKWISE AND IT IS DECREASED WHEN THE NUT IS TURNED COUNTERCLOCKWISE. THE CHECK SPRING (C) GETS TIGHTER AS THE TENSION STUD (B) IS TURNED CLOCKWISE WITH A SCREWDRIVER AND THE CHECK SPRING GETS LOOSER AS THE TENSION STUD IS TURNED COUNTER-CLOCKWISE.

THE MACHINE IS CORRECTLY ADJUSTED BEFORE LEAVING THE FACTORY TO SEW A PERFECT STITCH. NOTE; ALL TENSION ADJUSTMENTS MUST BE MADE WHILE THE PRESSER FOOT IS DOWN.

BOBBIN THREAD TENSION (FIG 9-E)

ORDINARILY A PERFECT STITCH CAN BE SEWN BY VARYING THE TENSION OF THE NEEDLE THREAD, HOWEVER IT IS SOMETIMES NECESSARY TO ADJUST THE BOBBIN THREAD TENSION (B). THIS TENSION MAY BE INCREASED BY TURNING THE TENSION SCREW (T) ON THE BOBBIN CASE TO THE RIGHT AND DECREASED BY TURNING SCREW TO THE LEFT.

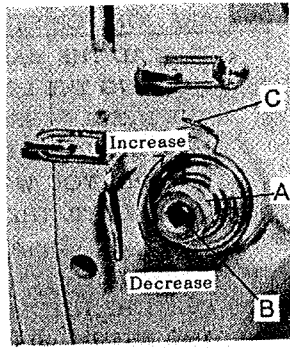

Fig 9D

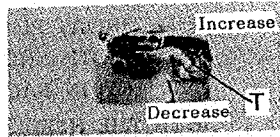

Fig 9E

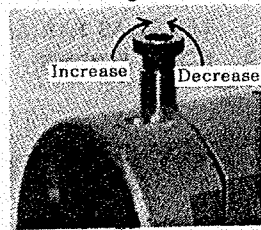

Fig 10

REGULATING THE PRESSURE OF THE PRESSER FOOT

THE PRESSURE OF THE PRESSER FOOT SHOULD BE ADJUSTED ACCORDING TO THE TYPE OF MATERIAL BEING SEWN THE HEAVIER THE MATERIAL THE HEAVIER THE PRESSURE. THE LIGHTER THE MATERIAL THE LIGHTER THE PRESSURE. THE PRESSURE SHOULD BE ONLY HEAVY ENOUGH TO PREVENT THE MATERIAL FROM RISING WITH THE NEEDLE AND TO ENABLE THE FEEDER TO MOVE THE FABRIC ALONG EVENLY. THE PRESSURE BECOMES TIGHTER AS THE REGULATING THUMB SCREW IS TURNED CLOCKWISE AND LOOSER AS THE THUMB SCREW IS TURNED COUNTER CLOCKWISE.

STITCH REGULATOR AND REVERSE SEWING OR TACKING

1. WHEN THE NUMBER 0 ON THE DIAL (A) IS SET UPPERMOST ON A VERTICAL LINE, THE FEEDER DOES NOT MOVE THE MATERIAL.
2. WHEN THE DIAL (A) IS TURNED COUNTER-CLOCKWISE AND LEVER (B) IS RAISED AS FAR AS IT WILL GO THE MACHINE MAKES FORWARD STITCHES INCREASING IN SIZE AS THE DIAL IS TURNED TOWARD THE LARGER NUMBERS.
3. FOR REVERSE SEWING, LOWER THE LEVER (B) AS FOR AS IT WILL GO. BY MOVING THE LEVER UP AND DOWN DURING SEWING YOU CAN MAKE FORWARD OR REVERSE STITCHES CONTINUOUSLY AND YOU CAN MAKE USE OF THIS FEATURE FOR LOCKING THE THREAD AT THE START OR END OF SEAMS.

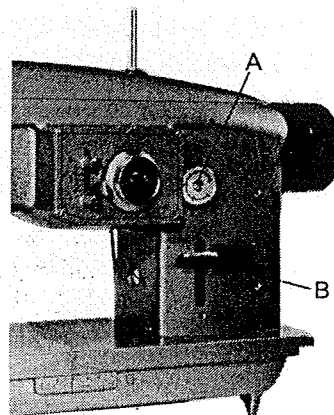

Fig 11

STRAIGHT AND ZIGZAG SEWING

TURN THE ZIGZAG REGULATING KNOB Z (Fig. 12), TO THE LEFT AS FAR AS IT WILL GO. THIS WILL CAUSE THE MACHINE TO SEW A STRAIGHT STITCH. TURNING THIS KNOB TO THE RIGHT WILL PRODUCE A ZIGZAG STITCH WHICH WILL BECOME WIDER, THE MORE THIS KNOB IS TURNED TO THE RIGHT (IN A CLOCKWISE DIRECTION). THE WIDEST ZIGZAG STITCH IS BEING SEWN WHEN THE KNOB Z CANNOT BE TURNED ANY FURTHER.

NOTE: THE ZIGZAG REGULATING KNOB CAN BE MOVED INTO ANY DESIRED POSITION WHILE THE MACHINE IS RUNNING. DO NOT ADJUST THE ZIGZAG REGULATING KNOB WHEN MACHINE IS AT REST AND THE NEEDLE IS IN THE MATERIAL. DISREGARDING THIS ADVICE MAY RESULT IN BROKEN OR BENT NEEDLES. TURN HANDWHEEL TOWARD YOU TO RAISE NEEDLE OUT OF MATERIAL BEFORE ADJUSTING THE KNOB.

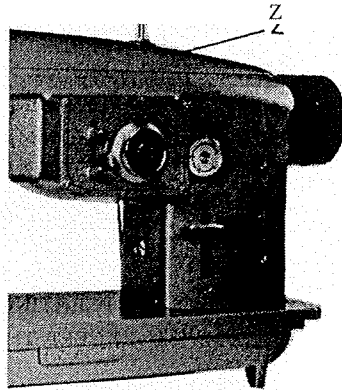

Fig 12

SETTING THE NEEDLE BAR AT THE CORRECT HEIGHT

MAKE SURE THAT THE NEEDLE IS PUSHED UP INTO THE NEEDLE BAR AS FAR AS IT WILL GO. REMOVE THE FACE PLATE. SET ZIGZAG CONTROL KNOB FOR STRAIGHT STITCH SEWING AND TURN HAND WHEEL TOWARD YOU UNTIL THE NEEDLE REACHES THE LOWEST POINT OF ITS DOWNWARD STROKE. SEE THAT THE NEEDLE ENTERS THE NEEDLE SLOT IN THE THROAT (NEEDLE) PLATE AT THE VERY CENTER. IF IT DOES NOT ADJUST THE NEEDLE BAR FRAME PITMAN ECCENTRIC STUD (FIG. 2) AS DESCRIBED IN THE FOLLOWING PAGES. AFTER MAKING THE NEEDED ADJUSTMENTS TO THE NEEDLE POSITION PROCEED IN THE FOLLOWING MANNER: REMOVE THE SLIDE PLATE, NEEDLE PLATE AND FEED DOG. CONTINUE TURNING HANDWHEEL TOWARD YOU UNTIL THE NEEDLE BAR HAS RISEN APPROXIMATELY $\frac{3}{32}$ " ABOVE ITS LOWEST POSITION. THE POINT OF THE SEWING HOOK SHOULD NOW BE AT THE CENTER OF THE NEEDLE AT A DISTANCE APPROXIMATELY $\frac{3}{32}$ " ABOVE THE EYE.

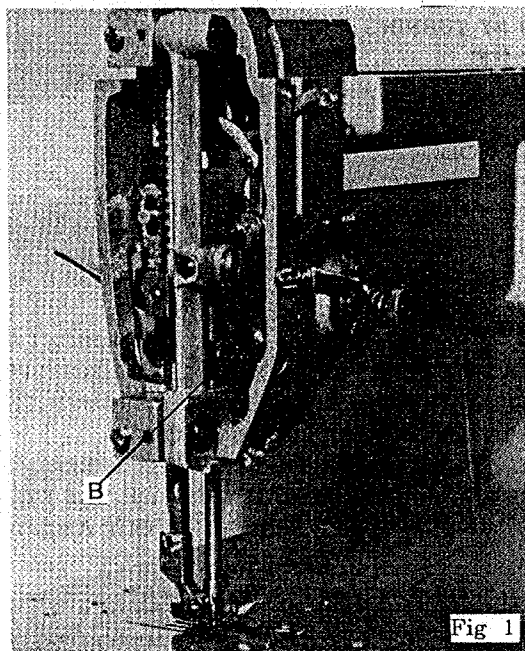
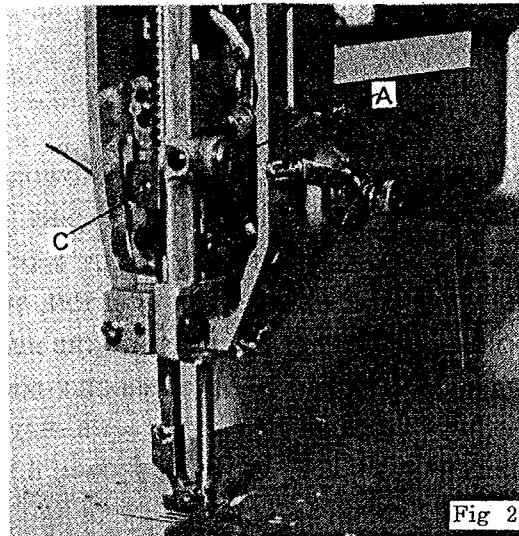

Fig 1

IF ADJUSTMENT SHOULD BE REQUIRED LOOSEN THE SET SCREW "B" (FIG 1) IN THE NEEDLE BAR CONNECTING STUD TO RAISE OR LOWER THE NEEDLE BAR AS NECESSARY. BE SURE TO TIGHTEN THE SET SCREW ONCE YOU HAVE MADE THIS ADJUSTMENT.

CENTERING THE NEEDLE IN THE THROAT (NEEDLE) PLATE

IF IT IS INDICATED THAT THE NEEDLE NEEDS CENTERING WITHIN THE SLOT IN THE NEEDLE OR THROAT PLATE, SET THE MACHINE FOR STRAIGHT SEWING AND TURN HANDWHEEL TOWARD YOU UNTIL THE NEEDLE BAR REACHES THE LOWEST POINT OF ITS DOWNWARD STROKE. LOOSEN SET SCREW "C" (FIG 2) AND TURN ECCENTRIC STUD "A" (FIG. 2) UNTIL THE NEEDLE IS CENTERED CORRECTLY. TIGHTEN SET SCREW "C".



SET ZIG ZAG KNOB TO WIDEST ZIG ZAG STITCH AND TURN THE HANDWHEEL TOWARD YOU AND OBSERVE THE PASSAGE OF THE NEEDLE THROUGH THE NEEDLE (THROAT) PLATE. IT SHOULD PASS AT ABOUT AN EQUAL DISTANCE FROM EITHER END OF THE NEEDLE SLOT WHEN MAKING THE LEFT AND RIGHT ZIG ZAG STITCH - IF NECESSARY, READJUST THE ECCENTRIC STUD "A" (FIG. 2) AS DESCRIBED IN THE PREVIOUS PARAGRAPH.

TIMING THE SEWING HOOK

REMOVE PRESSER FOOT, SLIDE PLATE, THROAT (NEEDLE) PLATE AND BOBBIN CASE. REMOVE THE FEED DOG TOO.

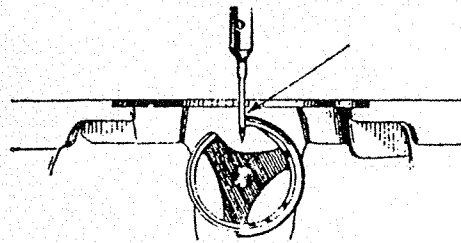

Fig 3

PLACE A NEW NEEDLE IN THE MACHINE AND TURN HANDWHEEL TOWARD YOU UNTIL THE NEEDLE BAR REACHES ITS LOWEST POINT. CONTINUE TURNING AND ALLOW THE NEEDLE BAR TO RISE ABOUT $\frac{3}{32}$ " WHILE ON ITS UPWARD STROKE. WITH NEEDLE BAR IN THIS POSITION, THE POINT OF THE SEWING HOOK SHOULD BE AT THE CENTER OF THE NEEDLE (FIG. 3). IF THE SEWING HOOK IS NOT TIMED CORRECTLY LOOSEN THE THREE SET SCREWS IN ITS HUB. TURN THE HOOK ON ITS SHAFT TO ALIGN THE POINT OF THE HOOK WITH THE CENTER OF THE NEEDLE, AS SHOWN IN FIGURE 3. TIGHTEN THE THREE SET SCREWS.

TO REMOVE AND REPLACE THE SEWING HOOK

REMOVE THE NEEDLE, SLIDE PLATE AND BOBBIN CASE. TAKE OUT SCREW "D" (FIG. 4) AND REMOVE HOOK RETAINER "E" (FIG. 4). LOOSEN THE THREE SET SCREWS IN THE HUB. TURN HANDWHEEL UNTIL THE THREAD GUARD (WIDEST PART) OF THE HOOK IS AT THE BOTTOM THEN REMOVE THE SEWING HOOK FROM ITS SHAFT (FIG. 4).

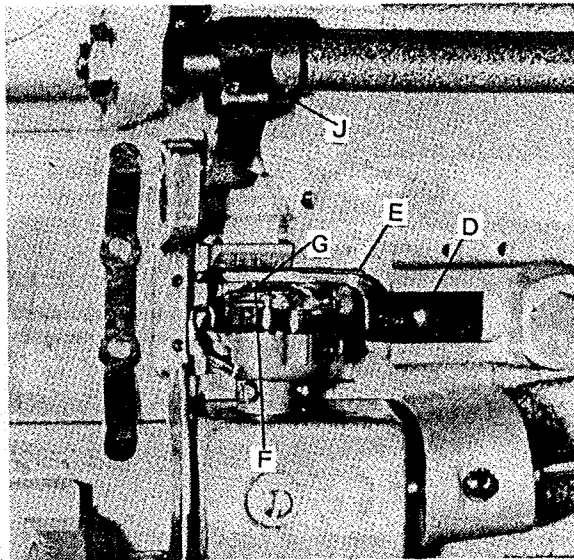

Fig 4

WHEN INSTALLING A NEW SEWING HOOK, HAVE THE THREAD GUARD AT THE BOTTOM. NOW TURN THE BOBBIN CASE HOLDER UNTIL THE NOTCH "F" IS AT THE TOP. REPLACE HOOK RETAINER "E" WATCHING THAT THE PROJECTION "G", NEAR ITS END (FIG. 1) ENTERS NOTCH "F" IN THE BOBBIN CASE HOLDER; FASTEN HOOK RETAINER TO THE UNDERSIDE OF THE BED BY MEANS OF THE SCREW. REPLACE THE NEEDLE AND TIME THE SEWING HOOK AS DESCRIBED IN THE PRECEEDING PARAGRAPH. RE-INSTALL BOBBIN CASE, THROAT PLATE AND SLIDE PLATE.

TIMING THE FEEDING MECHANISM

THE FEEDING MECHANISM IS TIMED AT THE FACTORY FOR AVERAGE STITCHING PERFORMANCE. NORMAL TIMING IS SUCH THAT THE FEED DOG TEETH, RISING FROM THEIR LOWEST POSITION SHOULD BE JUST FLUSH WITH THE SURFACE OF THE THROAT (NEEDLE) PLATE AFTER THE NEEDLE POINT HAS TRAVELLED ABOUT 5/16" ABOVE THE PLATE WHILE ON ITS UPSTROKE. TO ALTER THE TIMING OF THE FEEDING MECHANISM PROCEED AS FOLLOWS; REMOVE TOP COVER FROM THE MACHINE TURN THE HANDWHEEL TOWARD YOU UNTIL THE TWO SET SCREWS, LOCKING THE FEED ECCENTRIC INTO THE MAIN SHAFT, COME INTO VIEW (FIG. 5). LOOSEN BOTH SET SCREWS. LIGHTLY TAP THE FEED ECCENTRIC TOWARD YOU TO ADVANCE FEED TIMING. TO RETARD FEED TIMING, TAP ECCENTRIC TO ROTATE TOWARD THE REAR OF THE MACHINE.

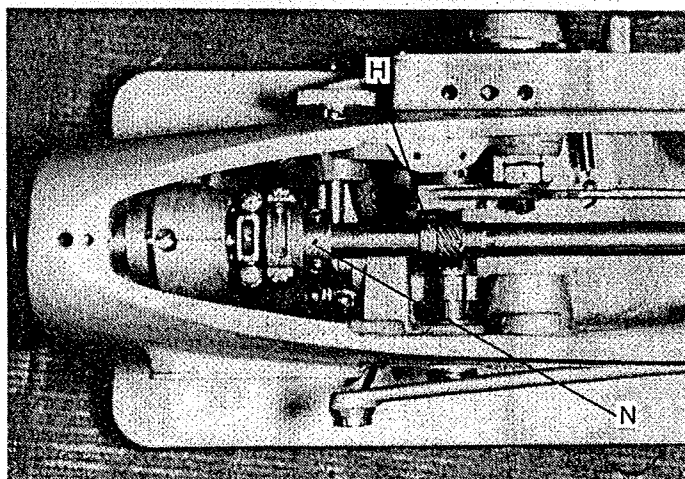

Fig. 5

NOTE; DO NOT MOVE ECCENTRIC MORE THAN ABOUT 1/16" OF A ROTATION AT A TIME. THEN TIGHTEN SET SCREWS AND CHECK FOR RESULTS.

TIMING THE MOVEMENT OF THE NEEDLE BAR FRAME

SET THE ZIGZAG KNOB TO STRAIGHT STITCH AND TURN THE HANDWHEEL. WATCH HOW THE NEEDLE MOVES IN AND OUT OF THE SLOT IN THE THROAT (NEEDLE) PLATE. IF THE NEEDLE IS NOT CENTERED IN THE SLOT, MAKE THE ADJUSTMENTS SUGGESTED IN THE PARAGRAPH ON THE CENTERING OF THE NEEDLE. NOW ADJUST THE NEEDLE TO PRODUCE WIDEST ZIG ZAG STITCH. TURNING THE HANDWHEEL TOWARD YOU, OBSERVE VIBRATION (SIDEWAYS MOVEMENT OF THE NEEDLE BAR). THE NEEDLE BAR ON ITS UPWARD MOVEMENT SHOULD BEGIN TO VIBRATE WHEN THE POINT OF THE NEEDLE IS NO LESS THAN ABOUT $3/32$ " ABOVE THE THROAT PLATE. IT SHOULD STOP VIBRATING WHEN THE NEEDLE HAS REACHED APPROXIMATELY THE SAME POSITION ON THE DOWNWARD SWING. TO ADJUST VIBRATION OF THE NEEDLE BAR, LOOSEN SET SCREW "H" (FIG. 5) VIBRATING CAM AND LIGHTLY TURN THE CAM ON ITS SHAFT, TIGHTEN SET SCREWS AND CHECK THE RESULTS. REPEAT THIS PROCEDURE UNTIL YOU ACHIEVE THE DESIRED RESULT.

TO RAISE OR LOWER THE FEED DOG

WHEN AT ITS HIGHEST POSITION, THE FEED DOG SHOULD RISE ABOVE THE THROAT (NEEDLE) PLATE TO THE FULL DEPTH OF THE TEETH. TO ADJUST THE POSITION OF THE FEED DOG, LOOSEN SCREW '1' (FIG. 4) AND RAISE OR LOWER THE FEED DOG AS DESIRED, THEN TIGHTEN THE SCREW. WHEN RAISING OR LOWERING THE FEED DOG BE CAREFUL THAT ITS UNDERSIDE DOES NOT DROP SO LOW THAT IT STRIKES THE HOOK.

ADJUSTMENT OF THE THREAD TAKE UP SPRING

THE THREAD TAKE UP SPRING "K" (FIG. 6) SHOULD BE SET SO THAT WHEN THE EYE OF THE NEEDLE REACHES THE GOODS ON THE DOWNWARD STROKE OF THE NEEDLE BAR, THE SPRING WILL HAVE COMPLETED ITS ACTION AND WILL REST AGAINST THE STOP ON THE THREAD TAKE UP SPRING REGULATOR.

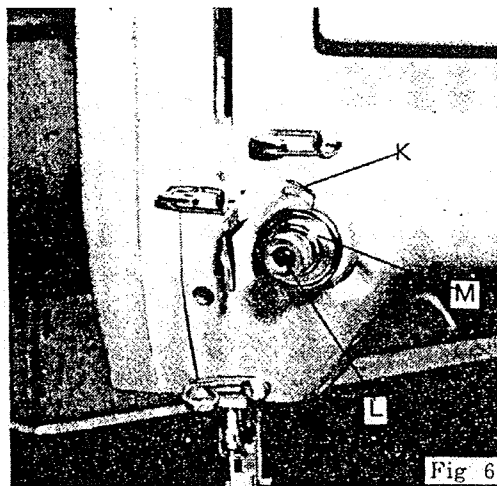

IF THE THREAD TAKE UP SPRING IS NOT SET AS OUTLINED ABOVE, LOOSEN SET SCREW "L" (FIG. 6) AND TURN TENSION STUD 'M' TO THE LEFT FOR REDUCED MOVEMENT OF THE SPRING OR TO THE RIGHT FOR MORE MOVEMENT. AFTER THE TAKE UP SPRING IS SET CORRECTLY TIGHTEN SET SCREW 'L'. REGULATION OF THE TENSION OF THE THREAD TAKE UP SPRING 'K' IS DONE BY TURNING THE TENSION STUD "M" TO THE RIGHT TO INCREASE TENSION OR TO THE LEFT TO DECREASE IT. THE TENSION OF THE SPRING SHOULD BE JUST ENOUGH TO TAKE UP THE SLACK OF THE NEEDLE THREAD UNTIL THE EYE OF THE NEEDLE REACHES THE MATERIAL ON ITS DOWNWARD MOVEMENT.

Consolidated Sewing Machine Corp.

Website: www.consew.com

MAIN office

131 W. 25th Street
New York, NY 10001
Tel: 212-741-7788
Fax: 212-741-7787
e-mail: consew@att.net

Miami, FL

4013 N.W. 79th Avenue
Miami, FL 33166
Tel: 305-471-0200
Fax: 305-471-0243
e-mail: miamisales@consew.com

Los Angeles, CA

2320 South Hill Street
Los Angeles, CA 90007
Tel: 213-745-8844
Fax: 213-745-8855
e-mail: lasales@consew.com

