

CONSEW *Since 1898*®

CONSOLIDATED SEWING MACHINE CORP.

└ INDUSTRIAL SEWING & CUTTING EQUIPMENT

INSTRUCTION MANUAL

FOR

CONSEW

347R-1A

CONSEW *Since 1898*®

CONSOLIDATED SEWING MACHINE CORP.

└ INDUSTRIAL SEWING & CUTTING EQUIPMENT

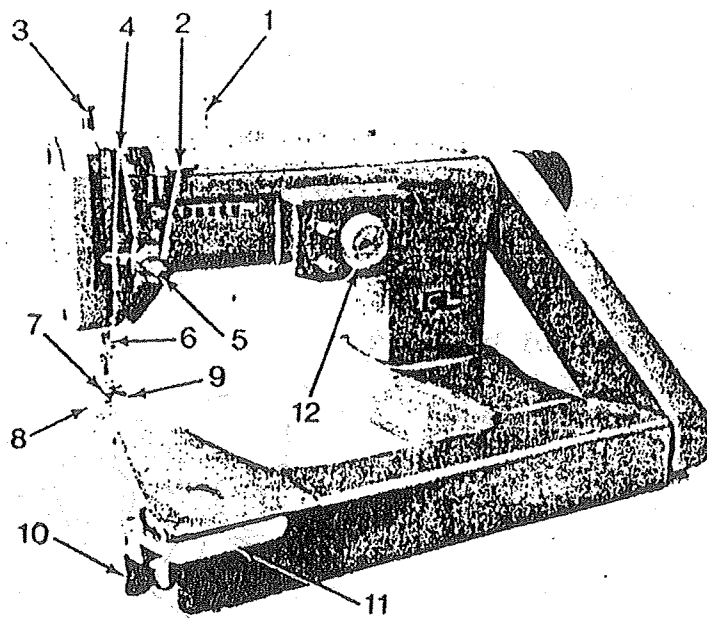

Fig. 1

NAMES OF MAIN PARTS

1. Spool pin
2. Thread guide
3. Pressure regulator
4. Take-up lever
5. Tension regulator
6. Needle bar
7. Presser foot
8. Arm end cap
9. Needle plate
10. Stitch length regulator
11. Feed direction lever (for tacking)
12. Zigzag width regulator

DESCRIPTION:

Model 347R is a Universal zigzag and straight stitch Feed-off-the-Arm sewing machine with a rotary hook producing a lockstitch.

NEEDLES

Model 347R use standard needles style 135 x 5.

THREAD

Left twist thread should be used in the needle. Either right or left twist thread can be used in the bobbin.

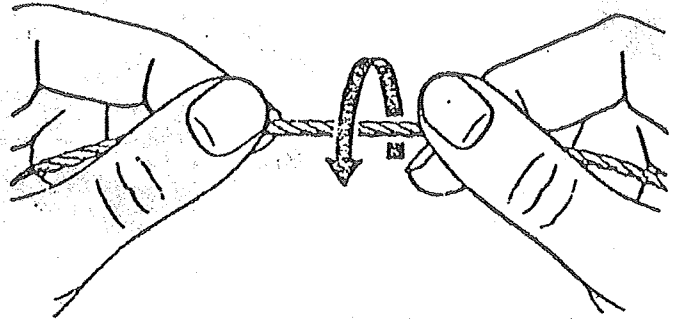

Fig. 2

HOW TO DETERMINE THE TWIST OF THE THREAD

Hold the thread as shown above, twist it between the thumb and fore-finger of your hands. If left twist, the strands will wind tighter. If right twist, the strands will unwind.

REMOVING THE BOBBIN CASE

1. Raise the needle bar to its highest point by turning the hand wheel toward you by hand.
2. Pull arm end cap toward rear of machine.
3. With left thumb and fore-finger placed under the bed, open the hinged latch (A) at the front of the bobbin case and by means of this latch remove the bobbin case from the sewing hook.
4. The bobbin falls out of the bobbin case into your hand when you close the bobbin case latch (A).

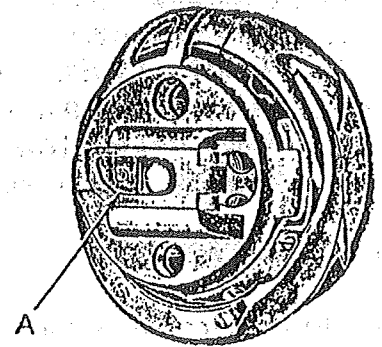

Fig. 3

WINDING THE BOBBIN

1. Place the bobbin (3) on winder spindle.
2. Pass the thread through the hole (4) of the bobbin winder thread guide and through the tension discs (5) from the rear.
3. Pull the end of the thread and wind it around the empty bobbin seven or eight times from the bottom up as shown by the arrow in Fig. 4.

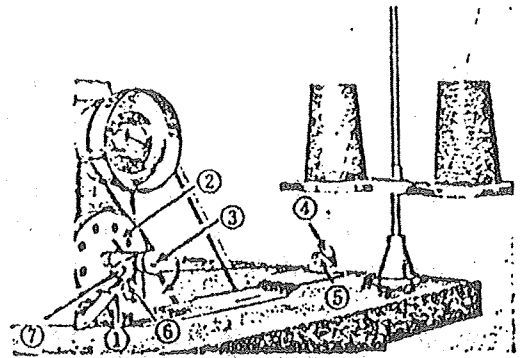

Fig. 4

4. Push the bobbin winder lever (1) down until the bobbin winder wheel (2) presses against the drive belt.
5. Start the machine and the thread will be wound up on the bobbin. When the bobbin is full, it will release automatically and stop turning.
6. Cut off the thread and remove the bobbin from the spindle.
7. You can easily adjust the maximum quantity of thread to be wound up on the bobbin by adjusting the screw (7) which controls latch (6).
8. If the thread does not wind evenly on the bobbin, adjust the position of the bobbin winder thread guide (4) by moving it to the right or left after loosening the screw.
9. Loosen the tension for fine thread by turning the nut in counter-clockwise direction.

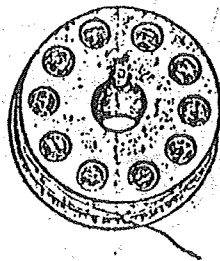

Fig. 5-A

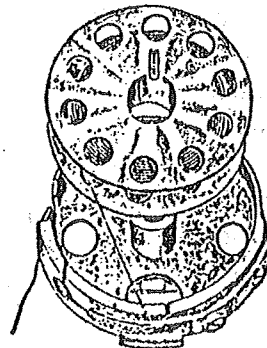

Fig. 5-B

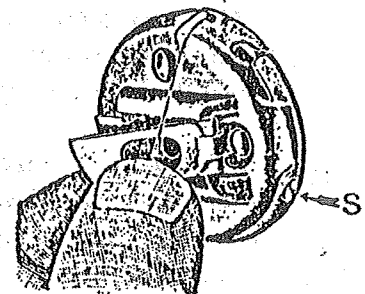

Fig. 5-C

THREADING THE BOBBIN CASE

1. Hold the bobbin case between the left thumb and fore-finger as shown above. With about 2 inches of thread trailing, hold the

bobbin between the thumb and first two fingers of the right hand as shown in Fig. 5A.

2. Insert the bobbin into bobbin case and pull the trailing thread into the slot, down and to the left, until it enters the grooved eye under the tension spring Fig. 5B, 5C.

INSERTING THE BOBBIN CASE

1. Raise the needle bar to its highest point by turning the hand wheel toward you by hand.
2. After sliding out the arm end cap, hold the bobbin case latch with left thumb and fore-finger to prevent the bobbin from falling out.
3. Press the bobbin case into the post on rotating loop taker until the protruding finger on the bobbin case enters the notch. Push the latch closed until an audible click can be discerned.

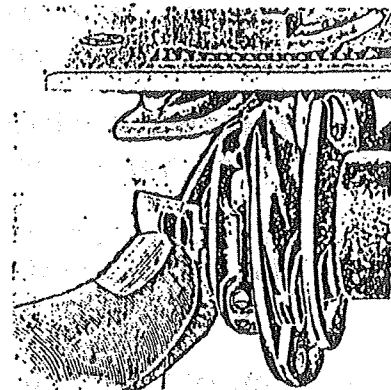

Fig. 6

NOTE:

BE SURE THAT THE PROTRUDING FINGER ENTERS THE NOTCH PROPERLY AND IN CORRECT POSITION.

THREADING THE MACHINE

1. Raise the thread take-up lever (7) to its highest position by turning the hand wheel toward you.
2. Lead the thread through the hole (1) of the spool pin and the three-hole thread guide (2).
3. Run the thread beneath and around the tension discs (3) from right to left.
4. Bring the thread over the loop of the check spring (4) and down again under the retaining hook (5) from right to left.

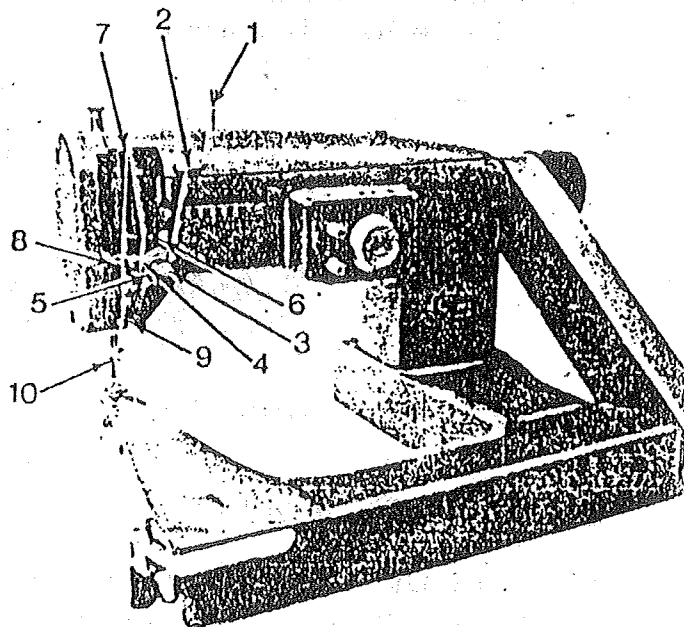

Fig. 7

- guide (6) on the way and through the eye at its tip from right to left.
6. Now run the thread down through the thread guides (8) and (9).
 7. Lead the thread through the needle bar thread guide (10).
 8. Now run the end of the thread through the eye of the needle from front to back, drawing it out about 2 inches.

PREPARATION FOR SEWING

1. Thread the machine.
2. Holding the loose end of the needle thread in your left hand, turn the hand wheel toward you with your right hand until the needle moves down and up again in its highest position.
3. Pull the needle thread gently and the bobbin thread will come up with it through the needle hole in the needle plate.
4. Place both ends of thread beneath and in back of the presser foot.
5. With the needle raised, place the material to be sewn beneath the presser foot and fully lower the presser foot lifter lever.
6. Start sewing.

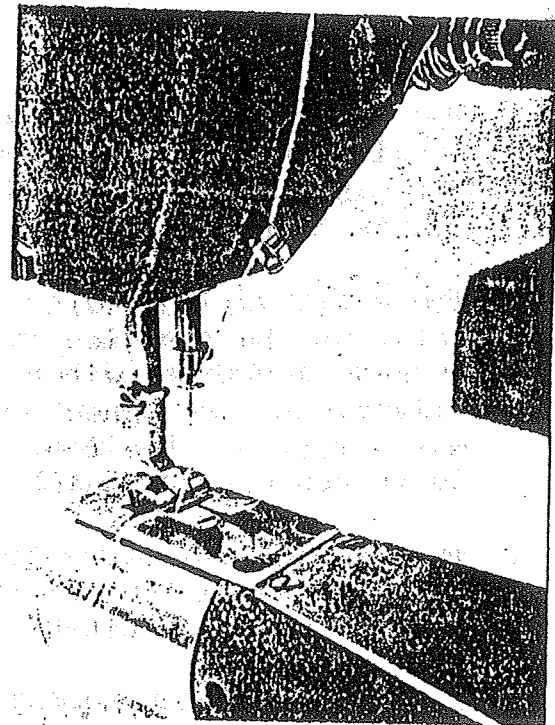

Fig. 8



Fig. 9-A



Fig. 9-B



Fig. 9-C

TENSION

For perfect stitching, the tension of the upper and lower threads should be balanced and just sufficiently tight to lock both threads in the center of the material (Fig. 9-A).

If the tension of the needle thread is too tight, or if that of the bobbin thread is too loose, the needle thread will lie straight along the upper surface of the material, making an imperfect stitch (Fig. 9-B).

TENSION

If the tension of the bobbin thread is too tight, or if that on the needle thread is too loose, the bobbin thread will lie straight along the underside of the material, also making an imperfect stitch. (Fig. 9-C).

REGULATING THE TENSIONS

1. Needle thread tension (Fig. 9-D).

- A. The tension is increased as the tension nut (A) is turned clockwise and it is decreased as the nut is turned counter-clockwise.
- B. The check spring (C) gets more tight as the tension stud (B) is turned clockwise with a screw driver, and the check spring gets more loose as the tension stud is turned counter-clockwise.
- C. The machine is correctly adjusted before leaving the factory to make a perfect stitch.

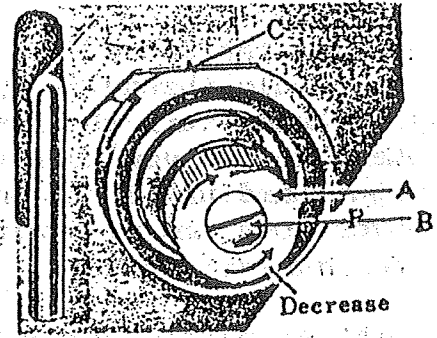

Fig. 9D

NOTE: ALL TENSION ADJUSTMENT MUST BE MADE WHILE THE PRESSER FOOT IS DOWN.

2. Bobbin thread tension.

- A. Ordinarily, a perfect stitch can be obtained by varying the tension of the needle thread only. However, it is sometimes necessary to adjust the bobbin thread tension.
- B. This tension may be increased by turning the tension screw (S) on the bobbin case to the right and decreased by turning screw to the left. (See Fig. 5-C).

REGULATING THE PRESSURE OF THE PRESSER FOOT

The pressure of the presser foot should be adjusted according to the type of material being sewn. The heavier the material, the heavier the pressure. The lighter the material, the lighter the pressure. The pressure should be only heavy enough to prevent the material from rising with the needle and to enable the feeder to move the work along evenly.

REGULATING THE PRESSURE OF THE PRESSER FOOT (Continued)

The pressure becomes tighter as the regulating thumb screw is turned clockwise, and looser as the thumb screw is turned counter-clockwise (Fig. 10).

STITCH REGULATOR AND REVERSE SEWING AND TACKING

1. Knurled head screw (A), Fig. 11 controls the stitch length at which the machine operates. To increase stitch length lightly depress lever (L) and turn screw (A) clockwise. Release lever and allow it to come to a stop against the tip of the adjustment screw. Try for results and if further adjustments in stitch length should be desired, turn screw (A) clockwise to further increase stitch length or counterclockwise to shorten stitch length.
2. For reverse sewing, lower the lever (L) as far as it will go.
3. By moving the lever up and down during sewing, you can easily make forward or reverse stitches continuously and at will. You can make use of this feature for locking the thread at the start or end of seams.

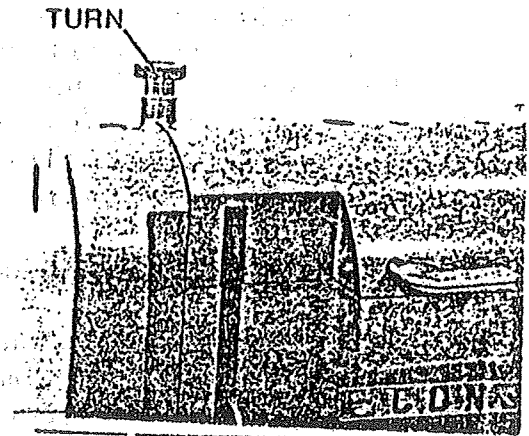

Fig. 10

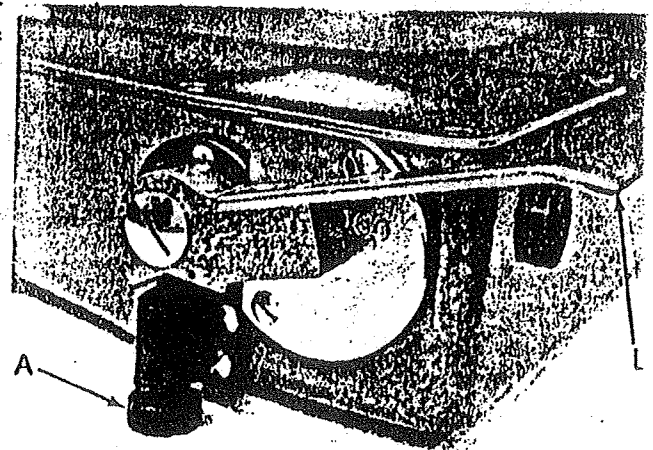

Fig. 11

STRAIGHT AND ZIGZAG SEWING

Ascertain that stops (S1) and (S2) (Fig. 12) are set at both extreme ends of their slot. If not, use screwdriver to loosen them about one turn and then tighten them in their extreme positions. Turning the zigzag regulating knob (Z) clockwise as far as it will go, will cause the machine to sew with a straight stitch. Turning this knob counter-clockwise will produce a zigzag stitch. Same will become wider the more this knob is turned in counter-clockwise direction. The widest zigzag

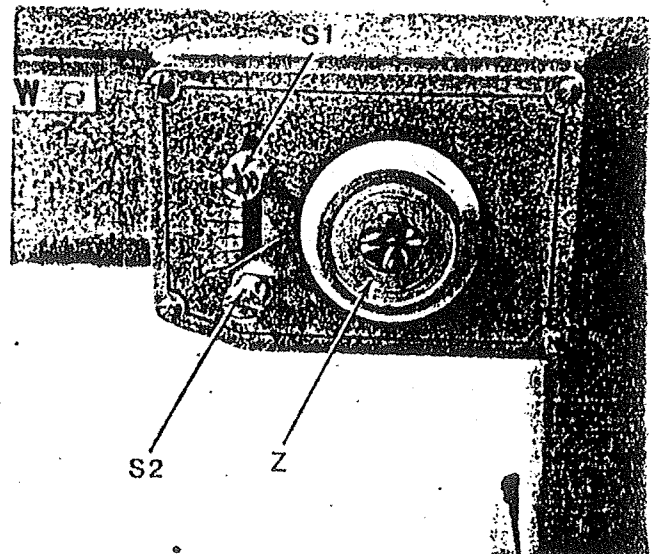

Fig. 12

stitch is being sewn when knob (Z) cannot be turned any further. This will occur when the pointer at the underside of knob (Z) points at the largest number on the dial and is stopped by Stop (S2).

STRAIGHT AND ZIGZAG SEWING (Continued)

When it is desired to control the width of the zigzag between certain minimum and maximum limits between the numbers on the dial, using a screwdriver set Stops (S1) and S2) to the selected widths. Be sure to set Stop (S'2) as far downward as possible when a straight stitch is desired.

NOTE:

The zigzag regulating knob can be moved into any desired position while the machine is operating. Do not turn zigzag regulating knob when machine is at rest and needle is in material. Disregarding this advice may have broken or bent needles as a consequence. Turn handwheel toward you to raise needle out of material before operating knob.

4. ADJUSTMENT OF UPPER FEED MECHANISM. (Ref. Fig. 12)

(For the type with upper feed mechanism,
146RB-1A and 146RBL-1A)

- A. To increase the lifting volume of outer foot.
 - 1. Loosen the adjusting belt A (#752).
 - 2. Raise the position of Rock Shaft Crank (#751) as you desire.
 - 3. Set the bolt tightly, after adjustment.
- B. To obtain more lifting volume of outer foot.
 - 1. Loosen the adjusting bolt B (#752)
 - 2. Raise the position of lifting crank connecting line (#748) as you desire.
 - 3. Reset the bolt tightly, after adjustment.
- C. To increase the feeding volume of order foot.
 - 1. Loosen the adjusting bolt C. (#733).
 - 2. Raise the position of feed correcting link (#732) as you desire.
 - 3. Reset the bolt, after adjustment.

ADJUSTMENT OF UPPER FEED MECHANISM

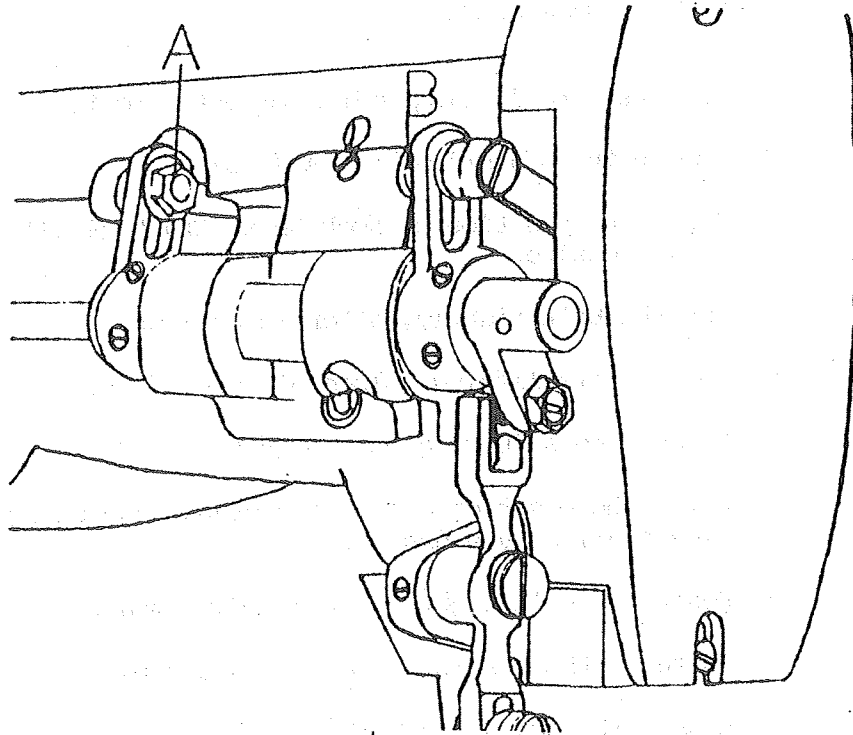

(Fig. 12)

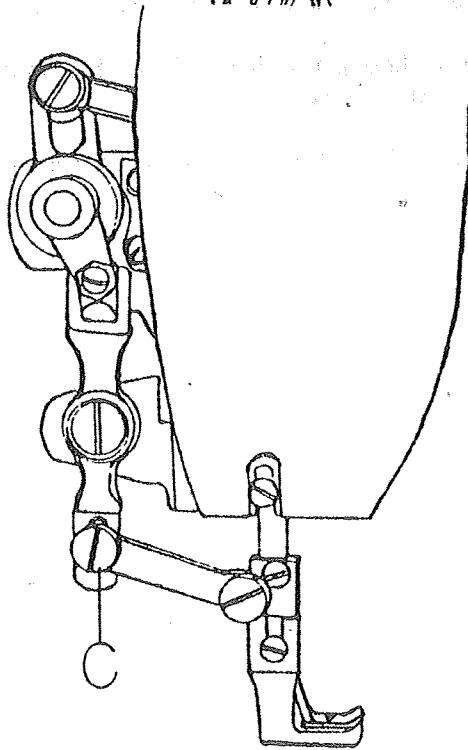



CONSOLIDATED SEWING MACHINE CORP.

└ INDUSTRIAL SEWING & CUTTING EQUIPMENT

MAIN OFFICE
131 WEST 25TH ST
NEW YORK, NY 10001
TEL: 212-741-7788
FAX: 212-741-7787

MIAMI OFFICE
7855 NW 29TH ST,
BAY 166
MIAMI, FL 33122
TEL: 305-471-0200
FAX: 305-471-0243

L.A. OFFICE
2320 SOUTH HILL ST.
LOS ANGELES, CA 90007
TEL: 213-745-8844
FAX: 213-745-8855