

CONSEW®

LUBRICATION (CW type)

Use white spindle oil. When starting the machine initially and after kept away for a long time without using at all, oil sufficiently to respective necessary parts before starting operation and pre-running. (↓ oiling point)

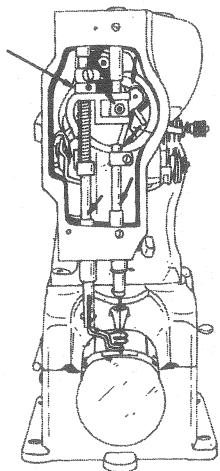

Model CW-1
Fig. 1

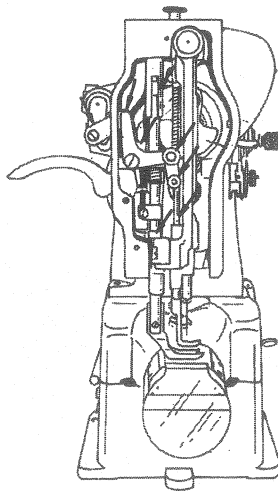

Fig. 2

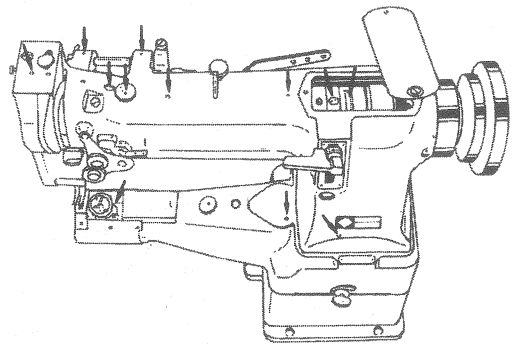

Fig. 3

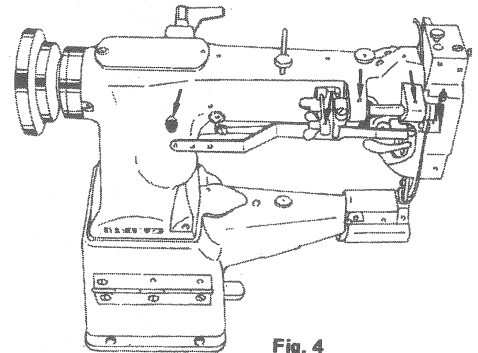

Fig. 4

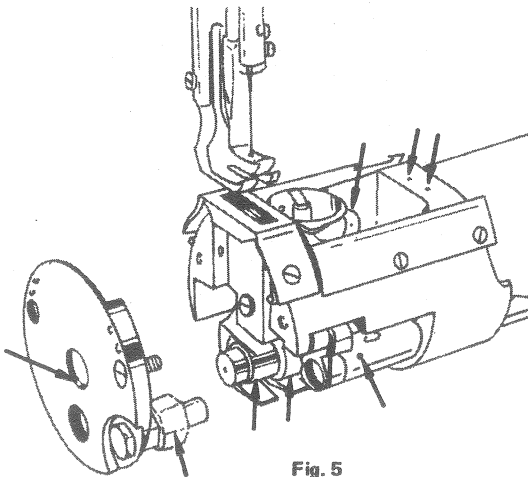
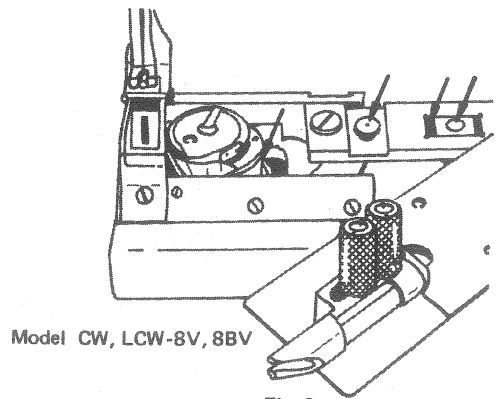

Fig. 5



Model CW, LCW-8V, 8BV

Fig. 6

LUBRICATION (LCW type)

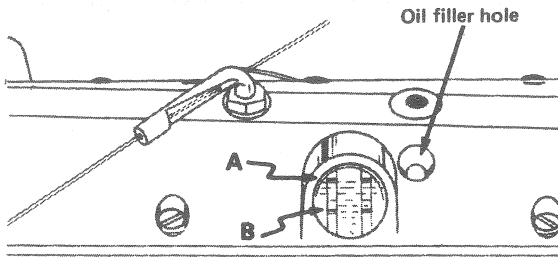

Fig. 7

To fill oil reservoir on top of machine until oil level reaches to upper reference line A. Always keep oil level is above lower reference line B.

OILING ADJUSTMENT FOR UPPER PART (LCW type)

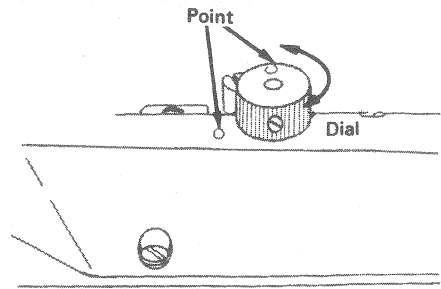

Fig. 8

While operating machine, lubrication to each spots of upper part of machine are made automatically. When the machine is in continuous operation, stop oiling for a while at your option. In that case, turn dial until two points fit together, then the dial comes down and lubrication is stopped.

NEEDLE

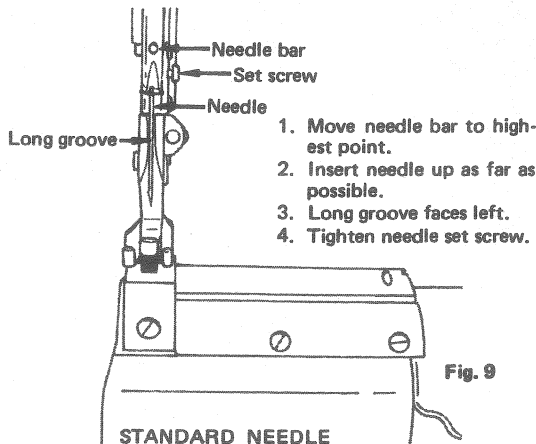

Fig. 9

STANDARD NEEDLE

FO x 3, #18CW-1
DP x 17, #18CW, LCW-8V, 8BV
LCW-6F
DP x 17, #22Other models

BOBBIN REMOVAL AND REPLACEMENT

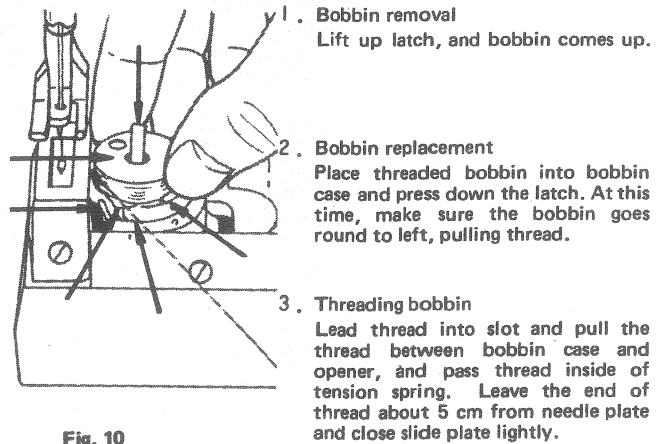

Fig. 10

1. Bobbin removal
Lift up latch, and bobbin comes up.
2. Bobbin replacement
Place threaded bobbin into bobbin case and press down the latch. At this time, make sure the bobbin goes round to left, pulling thread.
3. Threading bobbin
Lead thread into slot and pull the thread between bobbin case and opener, and pass thread inside of tension spring. Leave the end of thread about 5 cm from needle plate and close slide plate lightly.

LEADING TAPE (8V, 8BV type)

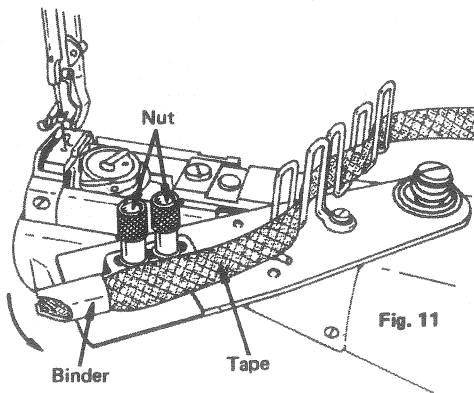

Fig. 11

1. Lift up nut and move binder toward you.
2. Lead tape as shown by Fig. 11.
3. Put the binder back to its former position.

WINDING BOBBIN

1. Place bobbin on spindle as far as it will go.
2. Lead thread as shown by Fig. 12 and wind several times on bobbin.
3. Press down lever for drive then start machine. Pulley will be disengaged from V-belt automatically after bobbin fills up with thread.

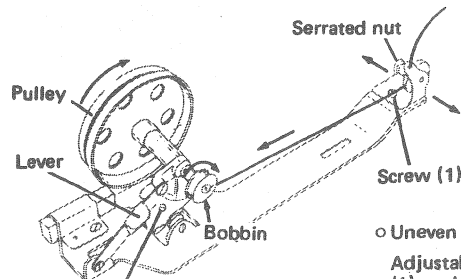
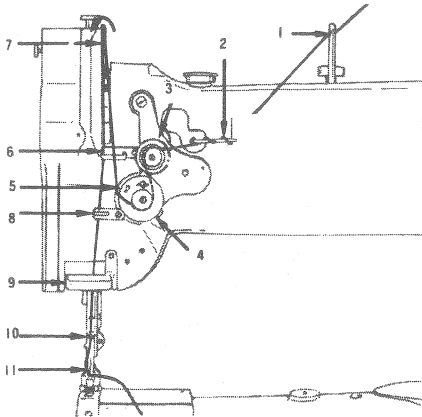

Fig. 12

- Uneven winding:
Adjustable by loosen screw (1) and move winder to right or to left.
- Winding amount:
Adjustable by screw (2).
- Winding strength:
Adjustable by serrated nut.

CW type



THREADING NEEDLE

LCW type

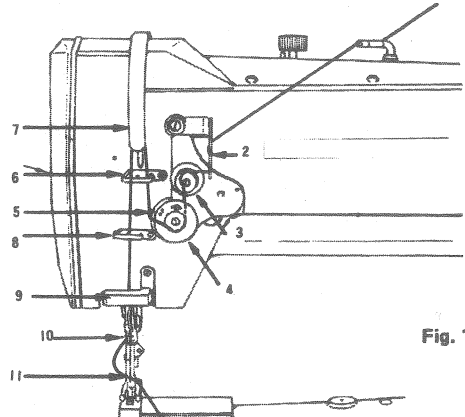

Fig. 13

Fig. 14

- Raise needle bar to highest point and lead thread from thread stand the following numerical order (1 ~ 11).
- Thread needle from left to right.

ADJUSTING LIFT OF ALTERNATING PRESSER FEET (CW, LCW-8, 8B, 8V, 8BV)

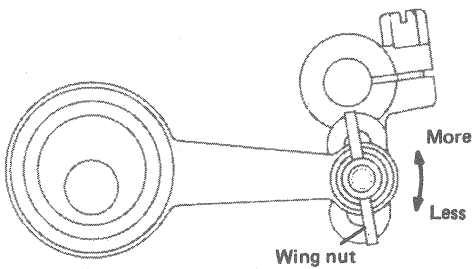
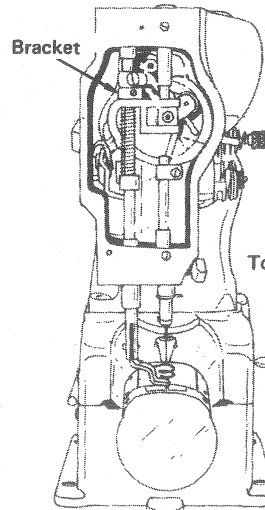

Fig. 15

To adjust, loosen wing nut and move link and stud assembly along slot.

ADJUSTING LIFT OF PRESSER FOOT (CW-1)



To adjust, turn the bracket

Fig. 16

THREAD TENSION

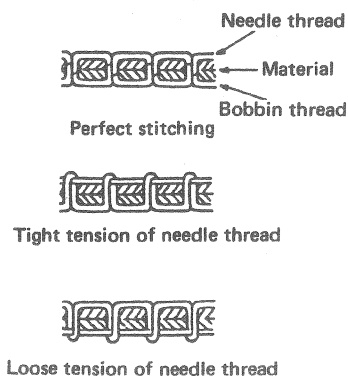

Fig. 17

NEEDLE THREAD

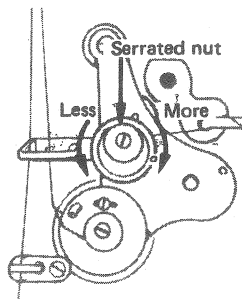

Fig. 18

To adjust, turn serrated nut

BOBBIN THREAD

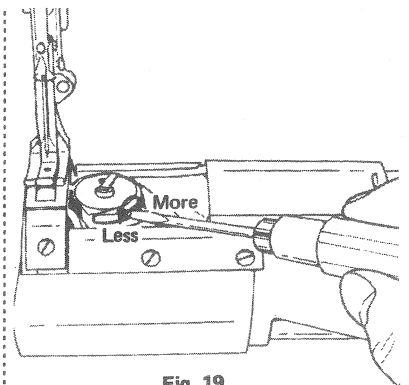

Fig. 19

To adjust, turn adjusting screw

TO REGULATE PRESSER FOOT PRESSURE

(CW type)

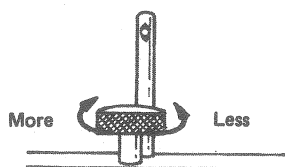

Fig. 20

(LCW type)

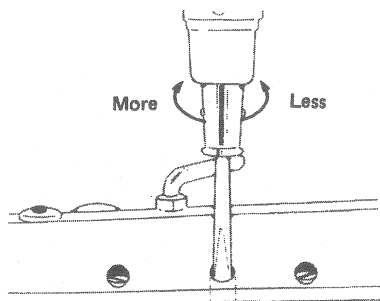

Fig. 21

The pressure on the material should be as light as possible, while still sufficient to insure correct feeding.

ADJUSTING STITCH LENGTH (7, 8, 8V type)

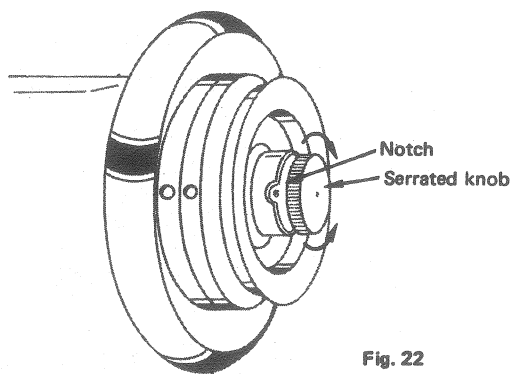

Fig. 22

To adjust, turn the serrated knob. It will be noticed that there is a notch in this hub wherein appears a number.

ADJUSTING STITCH LENGTH AND REVERSE STITCHING (7B, 8B, 8BV type)

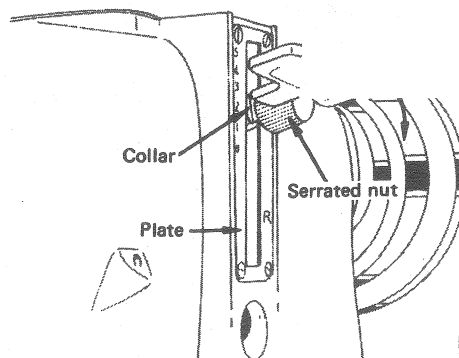

Fig. 23

To adjust, turn the serrated nut so that the reference mark on the collar comes in line with the desired number of stitch length on the plate. To reverse stitching, press down the lever as far as it will go.

ADJUSTING STITCH LENGTH (LCW-6F)

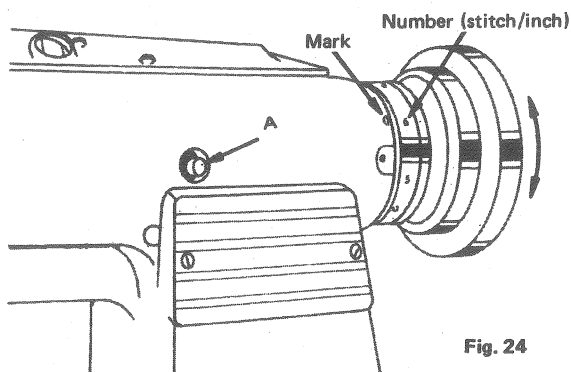

Fig. 24

Pressing down button A, turn pulley slowly toward you. Then plunger will enter into notch in feeding mechanism. Hold the plunger down and turn pulley either forward or rearward so that desired number on pulley may come at mark on arm. Then, release the plunger.

RE-ENGAGE SAFETY CLUTCH MECHANISM (except CW-1)

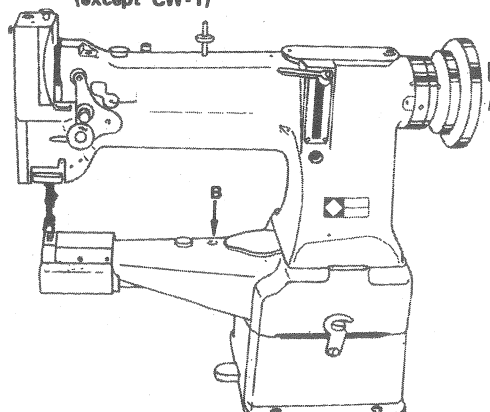

Fig. 25

1. Remove any foreign matter which may have lodged in hook. Do not use any sharp-edged tools.
2. Pressing button B and turn pulley rearward slowly to re-engage safety clutch.