

CM101 工业用暗缝机
INDUSTRIAL BLINDSTITCH MACHINE

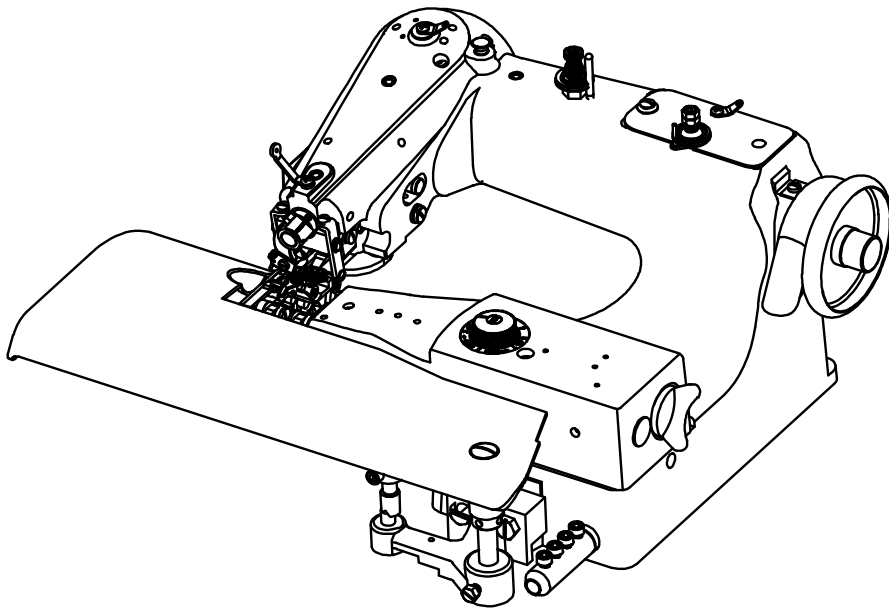

使用说明书及零件手册
INSTRUCTION MANUAL & PARTS LIST 19.12

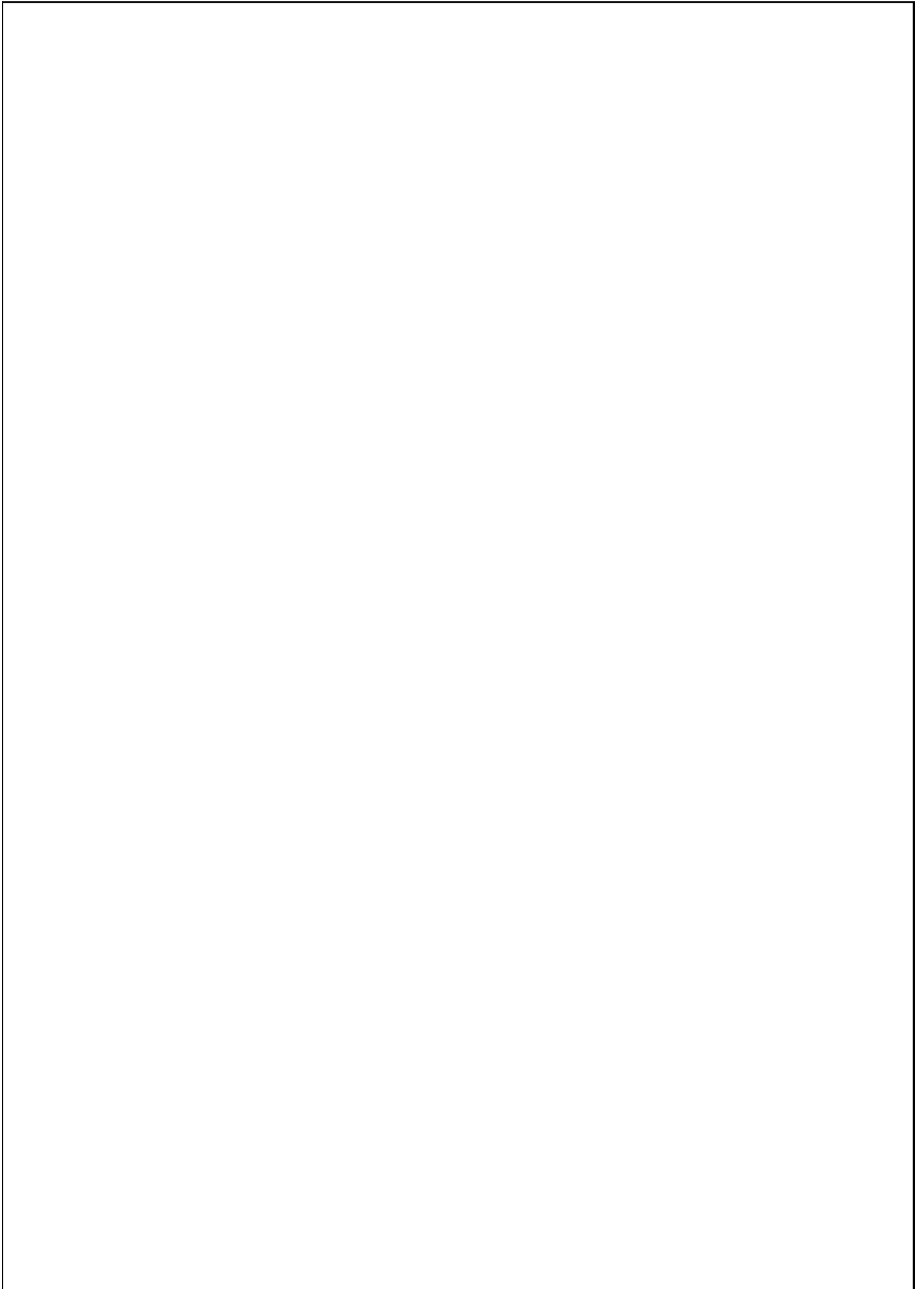

使用说明书

1. 取出暗缝机
2. 安装暗缝机
3. 机器轮盘的转动及速度
4. 加润滑油及维修保养
5. 更换机针
6. 穿线方法
7. 放入工作，开始缝制
8. 缝针穿透深度的调整
9. 针迹长度的调整
10. 缝针大小的调整
11. 跳缝装置
12. 取出缝制物
13. 压布板弹簧的调整 (CM-101-H型号)

使用说明 (1-6)

INSTRUCTION MANUEL (7-13)

零件手册 (14-39)

1、取出暗缝机

打开包装箱，仔细地移开盖子，不要损坏机器顶部凸出的部件。

小配件独立包装，不要丢弃包装里的包装物，除去机器上的油污、灰尘。

2、安装暗缝机

安装机杆到机器上，然后放在缝纫台上，杆离台边为13mm，用皮带连上暗缝机轮和电动机轮，暗缝机用三枚螺钉固定缝纫台上。

3、机器轮盘的转动及速度

机轮以顺时针方向转动，电动机同样是顺时针转动，新机器缝纫速度应控制在每分钟1800-2000缝迹，用了几个星期后提高到每分钟2500针迹。

4、加润滑油及维修保养

加一些高质量的润滑油后运转机器是非常重要的，新机器应该每天分几次加少量润滑油，然后一天一次是有效的。加油后，仔细地擦洗机器以免脏物进入机器，如果机杆没有降下，机器不要空转，以免损坏缝针。

5、更换机针（请更换弯曲或钝的缝针）

顺时针转动机轮直至缝针回到初始的位置，（最左边的位置）顺时针转动缝针穿透深度表，松动夹针螺钉，移去旧的或有缺陷的缝针，插入新针到底，然后夹紧螺钉，顺时针慢速转动机轮观察缝针移动。（见图1）

暗缝机所用各种型号缝针（见第10段）

图1

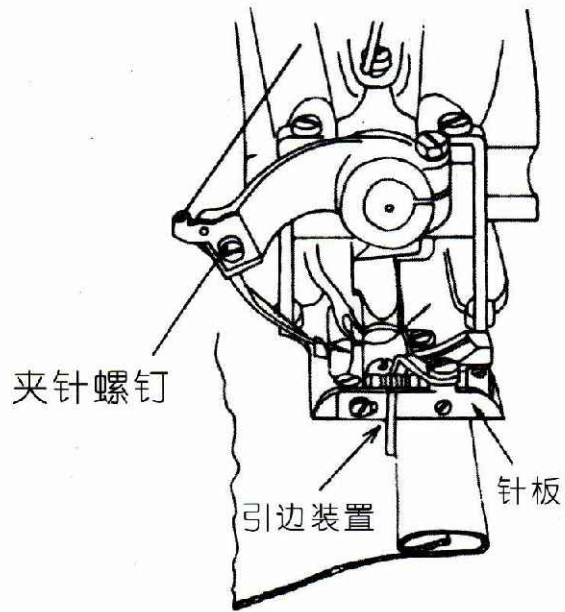

6、穿针方法

机轮顺时针方向运转使针夹转到最左边的位置，从线轴轴出线至位于夹线盘后边的引线装置A，再通过两个夹线盘，然后通到引线装置B和引线装置C，通过针夹洞，从下面穿过针眼，留下5厘米长的线在针眼外面。（见图2）

图2

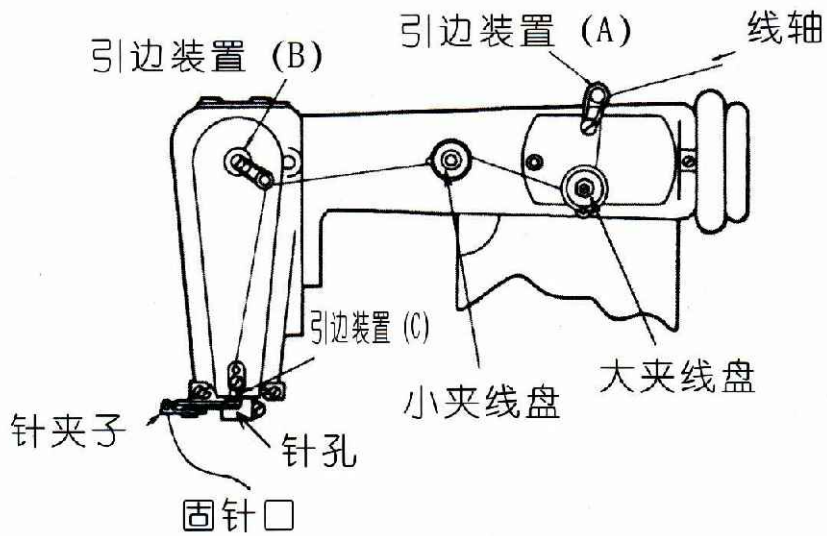

7、放入工作，开始缝制

压下机杆，使压脚和进料板有间隔，把工作沿着压脚引边装置放进去，完全放松机杆，慢速启动机器，观察布料通过引边装置。

8、缝针穿透深度调整

不同的布料对缝针穿透深度有不同的要求，因此可先在布料上暗缝数厘米检测缝针的穿透深度，调节器顺时针方向转动为穿透深度小，逆时针方向为穿透深度大。（图3）

图.3

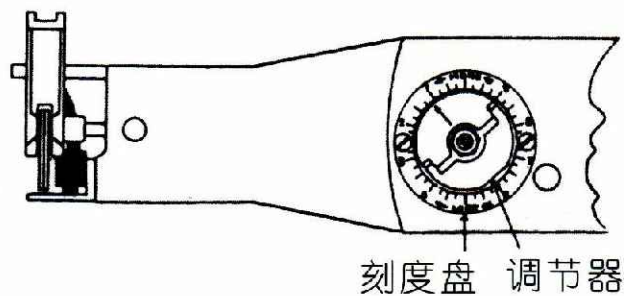

9、缝迹长度的调整：

用手转动机轮，推动撞针杆进入机器的槽子中，向前或向后转动机轮直到所要求的缝迹长度数字显现在指示器上。

(见图4)

图. 4

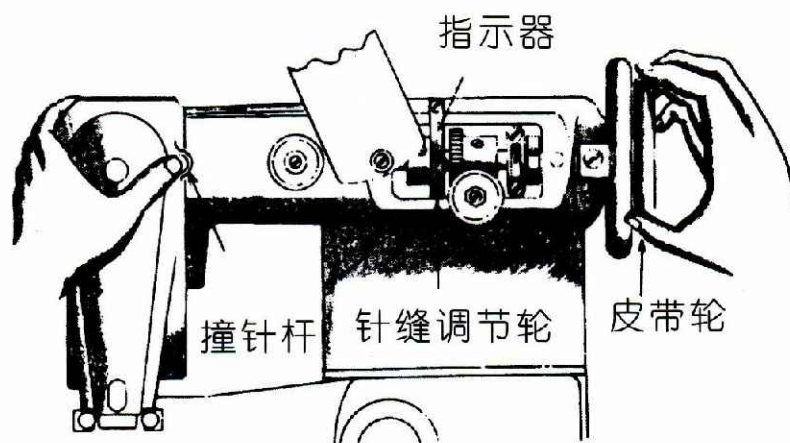

10、缝针大小的调整，采用LW X 6T系列缝针

尺寸	厚料
3 (11)	棉布、丝、奥纶、涤纶、及类似的轻重量织品
3 $\frac{1}{2}$ (14)	中等重量织品、羊毛织品及其它
4 (16)	制大衣的厚料，房子装饰用品

11、跳缝装置

位于机器右侧手柄为控制跳缝装置（见图5），当手柄指向没有跳缝的标志时，缝针缝线按原来的一针一线缝制，如指向跳缝标志时，缝针会跳一针缝针。缝线线迹会随着转动手柄的变化而变化。

图. 5

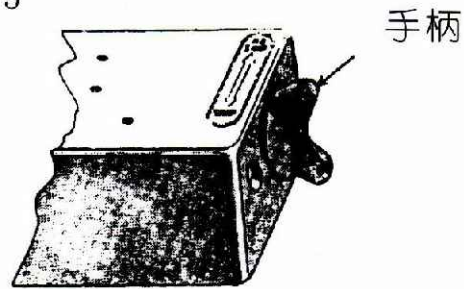

12、取出缝制物

停止机器，顺时针方向转动机轮，直到缝针完全脱离布料，压下机杆，快速把工件从机器中拉出，这将固定最后一针缝线。

13、压布板弹簧的调整 (CM-101-H)

压布板弹簧压力是由压布板调整螺钉调整，为了增加压布板弹簧压力，按顺时针方向旋转螺钉。它适合厚的布料。为了减小压力，按逆时针方向旋转螺钉，它适合于薄的布料。

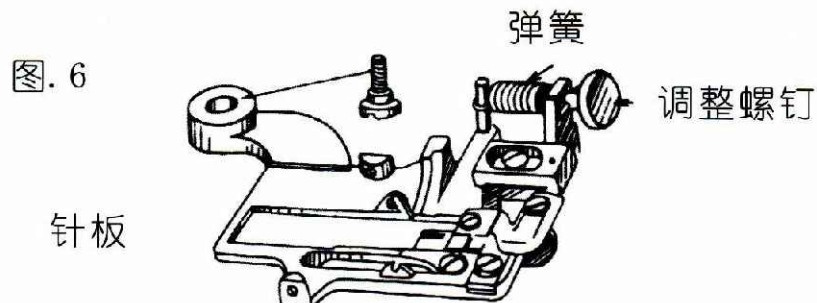

INSTRUCTION ANUEL

INDEX

- 1.Unpacking Machine
- 2.Setting-up Machine
- 3.Rotating Handwhel and speed
- 4.Oiling and Maintenance
- 5.Replacing Needle
- 6.Threading Machine
- 7.Inserting the Work and Starting to sew
- 8.Adjusting of Needle Penetration
- 9.Regulation Stitch Length
- 10.Recommendation Needle
- 11.Skip Stitch Device
- 12.Removing the Work from the Machine
- 13.Cloth Retainer Spring Adjusting(for CM-101-H)

1.Unpacking Mahcine

Open packing box by carefully removing its cover so as not to damage the machine or those of its parts which project from the top, such as the tension parts.

Small accessory parts are packed separately in individual packages. Do not discard any packing materials without prior scrutiny as to contents.

Clean from machine all greases, dirt or dust. Pay particular attention to area around the looper mechanism and looper.

2.Setting-up Machine

Assemble knee lifter lever to machine and place on sewing table so that lever is 13m/m distant from the front edge of the table. Line up belt groove in belt pulley of handwheel with belt groove of drive mechanism (motor or clutch).

Mark three screw hokes for fastening machine to sewing table and place felt pad under machine bed before machine is tightened down.

3.Handwheel Rotation and Speed

Turn handwheel only in direction away from operator for clockwise rotation. Be sure motor drive is wired up to obtain the same clockwise rotation. The recommended operating speed of a brand new machine is 1,800 to 2,000 stitches per minute. After a breaking-in the operation of the machine, the speed can be increased up to 2,500 stitches per minute.

4.Oiling and Maintenance

It is important not to operate the machine before oil of good quality has been filled in each oil hole along the top of machine. When using a new machine oiling should be done sparingly several times a day. Thereafter, oiling once daily will be sufficient. After oiling, wipe machine carefully to avoid soiling of the material.

Do not operate without material under the presser foot unless the knee lever is depressed. This will prevent damage of needle and feed dog as well as feed plates.

5. Replacing Needle

Turn handwheel away from operator (clockwise) until needle reaches the end of its return stroke (extreme left hand position). Adjust penetration dial to least amount of penetration (turn clockwise towards 1).

Remove old or defective needle by loosening needle clamp screw. Insert new needle into seat in needle clamp as far as it will go. Tighten needle clamp screw.

Turn handwheel slowly away from operator and observe movement of needle. The curved portion of the needle should bear slightly on the needle guide groove in the left hand of the presser foot.

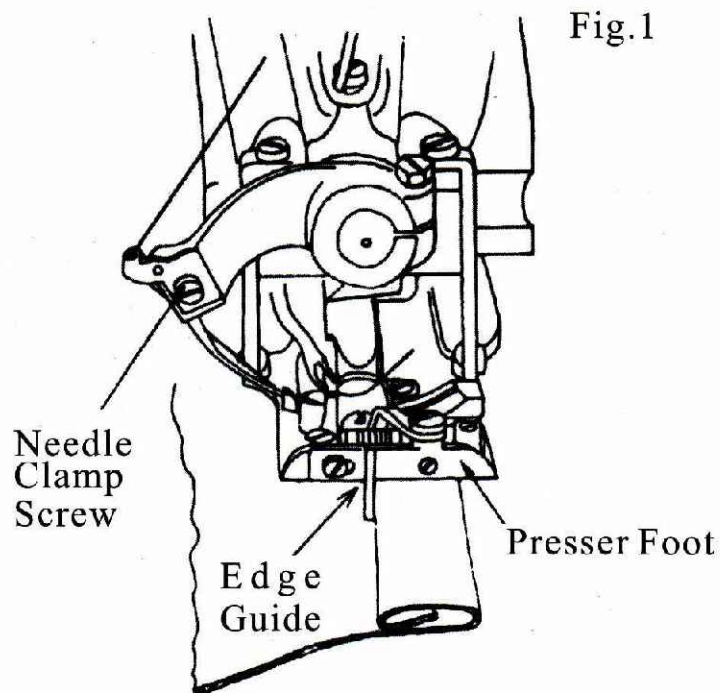

Fig.1

Always replace bent or blunt needles. They affect the satisfactory operation of the machine. (See Fig.1)

See par.10 concerning needle system to be used in Blindstitch Machines.

6. Threading Machine

Turn handwheel of machine in clockwise direction away from operator until needle carrier reaches its furthest lefthand position.

And proceed as follows:

Draw thread from spool on thread stand and pass it through thread guide (A) which is located on rear side of thread nipper.

Place thread between tension discs of thread nipper and thread tension and lead it forward through thread guide(B) and pass it through thread guide(C) at the top of the arm near its front.

From there pass thread through hole in needle clamp and then through the eye of needle from below upward. Pull about 5cm of thread through the eye of needle. (see Fig2)

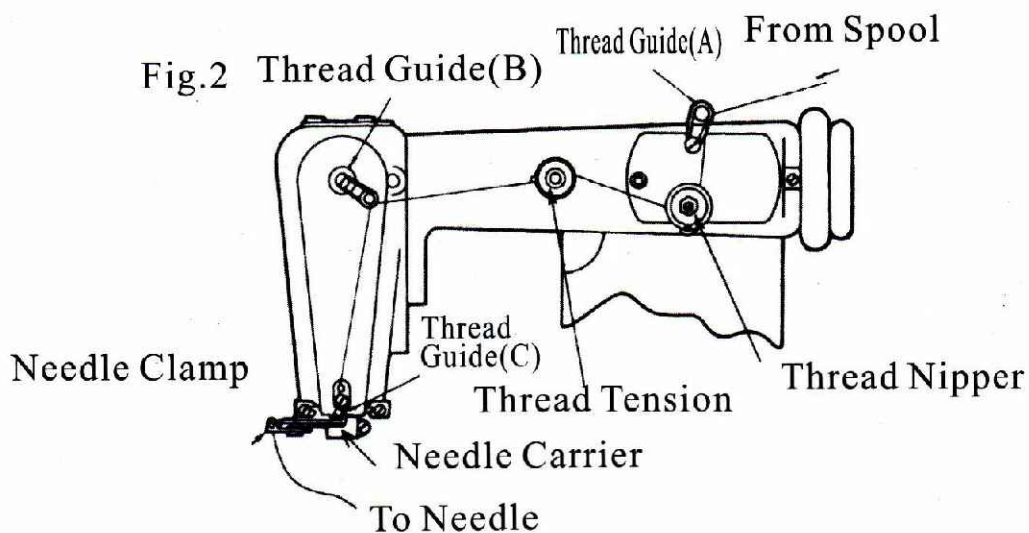

7.Inserting the work and Starting to Sew

Depress knee lifter.This causes the feed plate to swing downward and creates a gap between the presser foot and the feedplate.

Insert the work in the gap just opened in such a manner that the folded or sewn edge of the material is alongside the edge guide of the presser foot.(see Fig.1)

When the material is in proper positon,completely release the knee lifter.Get the machine started slowly and watch the material pass edge guide rather than to observe the action of the needle.

8.Adjustment of Needle Penetration

The type of material to be blindstitched governs the degree of needle penetration which is required.It is ,therefore.recommended to stitch a few centimeters as a test and make adjustments for penetration depending on the appearance of the trial stitching.

Turn regulator clockwise for less penetration and counter-clockwise for more penetration.(Fig.3)

Fig.3

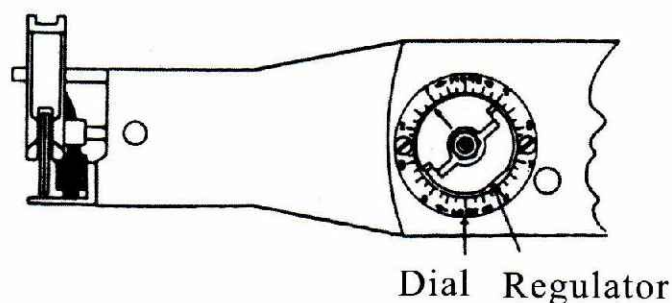

9. Stitch Length Regulation

Stitch length adjustment be easily effected by adjusting needle driving eccentric in arm.

Go about it as follows:

Turn handwheel by hand pushing plunger until same is felt to drop into a recess within the mechanism inside the arm of the machine.

With the plunger remaining depressed into this recess continue turning the handwheel either forward or in reverse until the desired number of stitches per inch is visible on indicator. (See Fig.4)

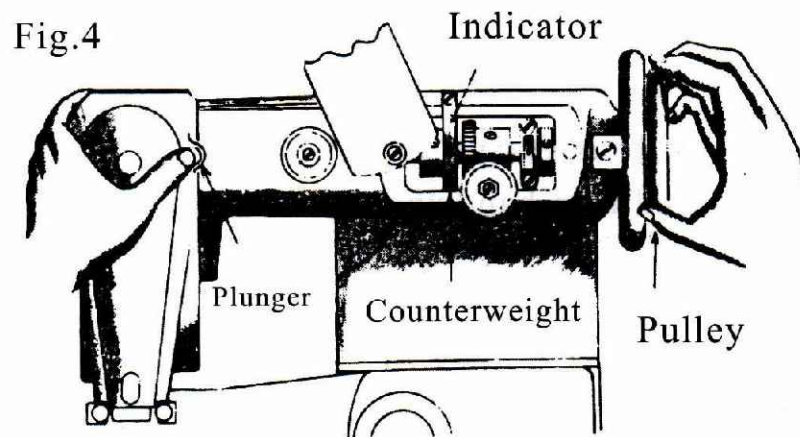

10..Needle Recommendation

The recommended needle is system LW X 61.

Size	Material
3 (11)	Cottons .Silks.Acetates,OrIon,Dacron and similar type of light weight fabrics.
3 ¹ / ₂ (14)	Medium weight materials.Woolens and Others.
4 (16)	Thick materials for coats,house furnishings.

11. Skip Stitch Device

The position of grip at the right side of the machine controls the skip stitch device. (see Fig.5)

When this grip points towards NO SKIP. The needle catches the material at each stitch. Pointing towards SKIP, the needle penetrates the material at every other stitch.

Be sure that grip is pushed completely in either direction and needle penetration redj used every time operation is changed from skip to nonskip.

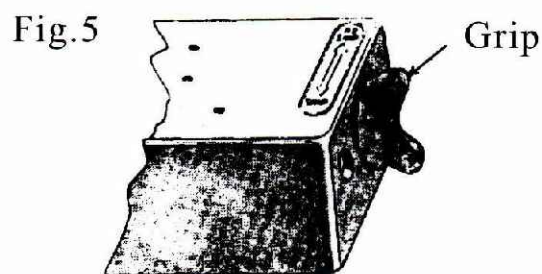

12. Removal of the Work from the Machine

Stop machine and turn handwheel away from operator until needle is completely out of the material. Press the knee lifter to the right and pull the work-piece rearward out of the machine with a quick stroke. This will lock the last stitch and break the thread.

13. Cloth Retainer Spring Adjustment (for CM-101-H)

The tension of cloth retainer spring can be adjusted by turning the cloth retainer spring adjusting screw (see Fig.6)

To increase the tension of cloth retainer spring, turn this screw to the right (clockwise). It is suitable for thicker material.

To decrease the tension, turn this screw to the left (counter-clockwise). It is suitable for thinner material.



零件手册

目 录

A、机架及盖部零部件 Machine Frame & Covers Components	14
B、主要传动轴部件 Main Shaft Mechanism Components	16
C、针摆装置及进料装置零部件 Needle Carrier & Feed Dog Mechanism Components	18
D、打环器装置及针板零部件 Looper Drive Mechanism & Presser Foot Parts Components	22
E、起菱盘及进料板机械零部件 Ridge Forming Disc & Feed Plate Mechanism Components	24
F、起菱盘摆动装置及机杆零部件 Disc Oscillating Mechanism & Knee Press Shaft Parts Components	28
G、压线装置零部件 Thread Tension & Nipper Parts Components	32
H、操作板，压杆及皮带部位的零部件 Work Plate , Knee Press & Belt Cover Parts Components	34
I、标准附件 Standard Accessories	36
J、型号C M - 1 0 1 - H 附加零部件 Work Plate , Knee Press & Belt Cover Parts Components	38

A、机架及盖部零部件
Machine Frame & Covers Components

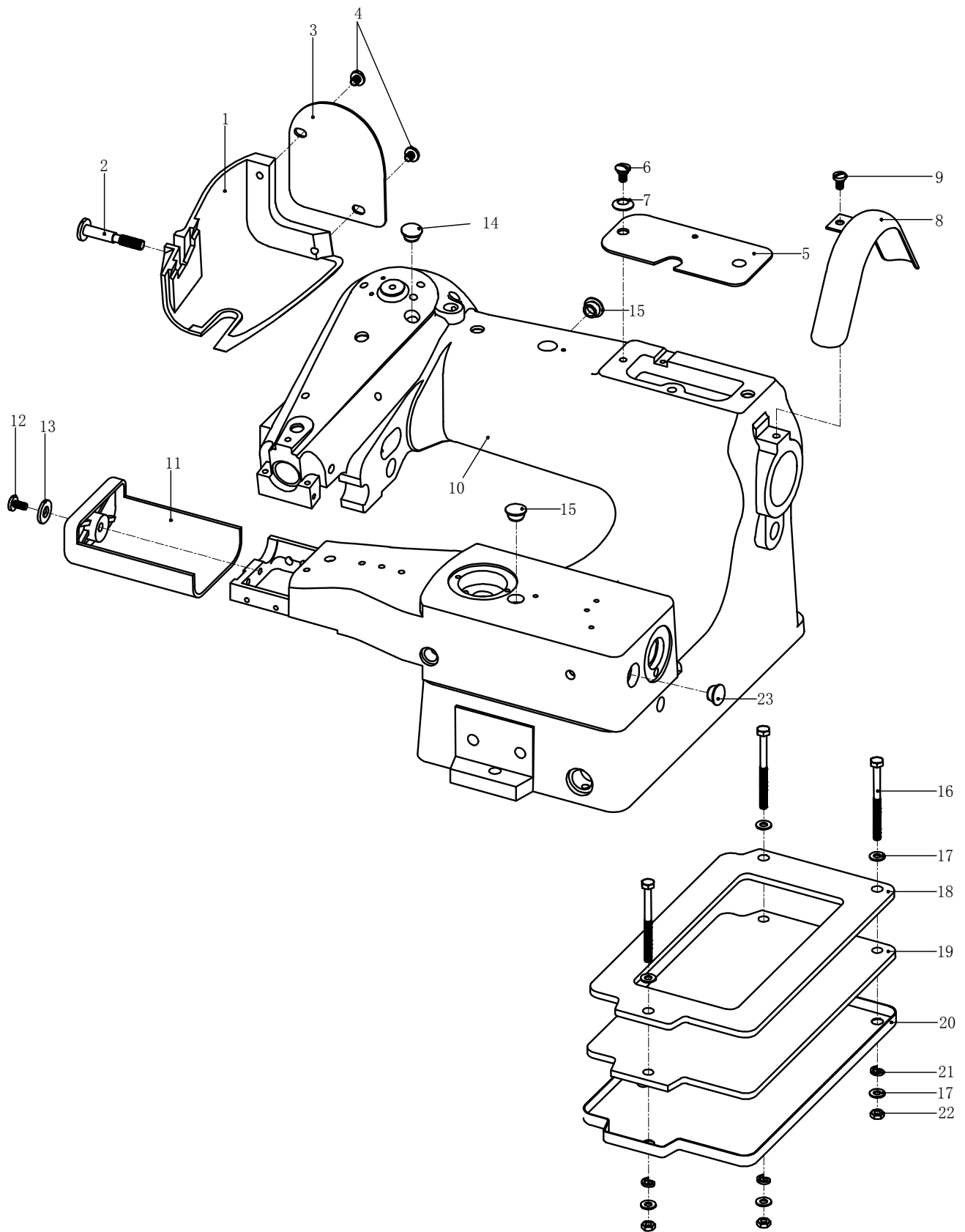

A、机架及盖部零部件

Machine Frame & Covers Components

序号 Ref.No	代号 Assemble.No	件号 Parts.No	部件名称 Description	数量 Num
1	101A-01	A01-01	边盖/Arm Side Cover	1
2	101A-02	LD00500	边盖固定螺钉/Screw(15/64-28×21)	1
3	101A-03	A01-03	边盖板/Arm Side Cover Plate	1
4	101A-04	LD00007	边盖板螺钉/ Screw(3/16-32×5.5)	2
5	101A-05	A01-05	顶盖板/Arm Top Cover Plate	1
6	101A-06	LD00501	顶盖板螺钉/Screw(3/16-32×5.8)	1
7	101A-07	DQ00004	顶盖板垫圈/Arm Top Cover Plate Washer	1
8	101A-08	A01-08	皮带护罩/Belt Guard	1
9	101A-09	LD00502	皮带护罩固定螺钉/Screw(3/16-32×8)	1
10	101A-10	A01-10-E	机架/Machine Frame	1
11	101A-11	A01-11	端面盖/End Cover	1
12	101A-12	LD00503	端面盖固定螺钉/Screw(11/64-40×10)	1
13	101A-13	DQ00026	垫片/Shim	1
14	101A-14	V01-39	橡皮塞/Rubber Stopper	1
15	101A-15	A01-01-B	橡皮塞/Rubber Stopper	2
16	101A-16	F J1-13	机器固定螺栓/Machine frame	3
17	101A-17	F J1-14	固定螺栓垫圈/Copper oil pipe line	6
18	101A-18	F J1-16-1	机器橡胶垫/Copper oil pipe 5	1
19	101A-19	F J1-21	机器羊毛毡/Rubber cap 16.5	1
20	101A-20	A01-13-1	机器底盘/Three-ring of thread take-up	1
21	101A-21	DQ00014	弹簧垫圈/Haploporeof thread take-up	3
22	101A-22	LM00006	固定螺栓螺母/Pendulum shaft frontal cover	3
23	101A-23	A01-01-C	橡皮塞/Rubber Stopper	1

B、主要传动轴部件
Main Shaft Mechanism Components

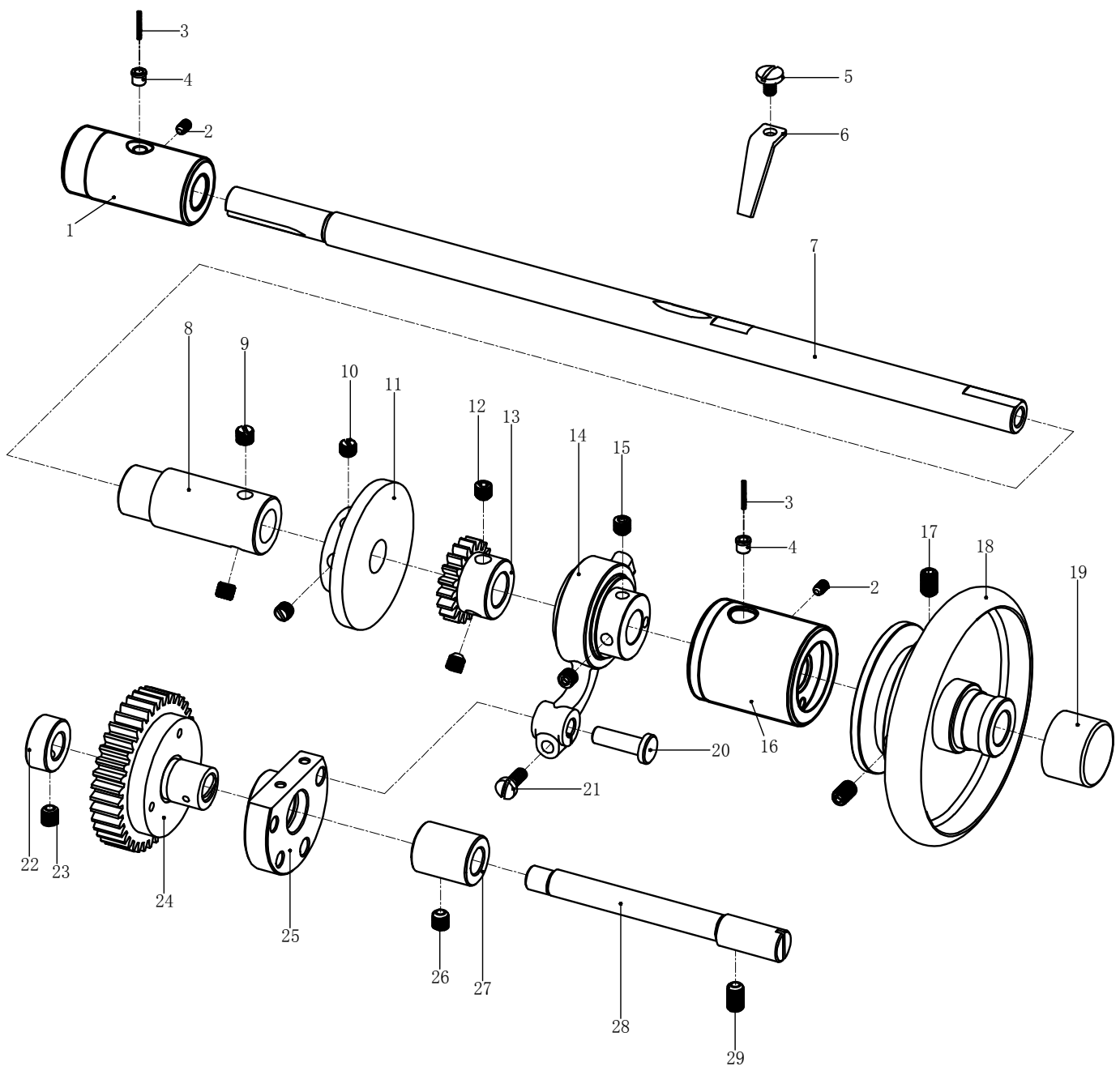

B、主要传动轴部件

Main Shaft Mechanism Components

序号 Ref.No	代号 Assemble.No	件号 Parts.No	部件名称 Description	数量 Num
1	101B-01	A02-01	主轴前套管/Main Shaft Bushing (Front)	1
2	101B-02	LD00001	主轴套管螺钉/Screw(M6×10)	2
3	101B-03	927C012	油线/The Oil Line	2
4	101B-04	A03-01	油盖/Oil Cap	2
5	101B-05	LD00504	缝迹长度指示器螺钉/Screw(9/64-40×5.7)	1
6	101B-06	A02-08	缝迹长度指示器/Stitch Length Indicator	1
7	101B-07	A02-11	主轴/Main Shaft	1
8	101B-08	A02-12	松紧线偏心器/Thread Tension Releasing Eccentric	1
9	101B-09	LD00505	松紧线索偏心器螺钉/Screw(1/4-40×5.2)	2
10	101B-10	LD00506	针缝调节轮螺钉/Screw(15/64-28×5)	2
11	101B-11	A02-05	针缝调节轮/Counterweight	1
12	101B-12	LD00003	主轴齿轮螺钉/Screw(M6×6)	2
13	101B-13	A02-14	主轴齿轮/Skip Stitch Gear (small)	1
14	101B-14	A02-16	偏连杆/Eccentric Rod Assmely	1
15	101B-15	LD00003	偏心连杆套管螺钉/Screw(M6×6)	2
16	101B-16	A02-10	主轴后套管/Main Shaft Bushing (Rear)	1
17	101B-17	LD00001	皮带轮螺钉/Screw(M6×10)	2
18	101B-18	A02-29	皮带轮/Hand Wheel	1
19	101B-19	A02-31	皮带轮橡皮盖/Hand Wheel Rubber Cap	1
20	101B-20	A06-11	偏心连杆销子/Eccentric Rod Stud	1
21	101B-21	LD00507	偏心连杆销子螺钉/Screw(11/64-40×11.8)	1
22	101B-22	K2-20	主轴齿轮轴环/Skip Stitch Gear Shaft Collar	1
23	101B-23	LD00003	主轴齿轮轴环螺钉/Screw(M6×6)	1
24	101B-24	A02-23	跳缝齿轮/Skip Stitch Gear Assembly	2
25	101B-25	A02-24	离心杆接头/Eccentric Rod Connection	1
26	101B-26	LD00003	跳缝齿轮轴环螺钉/Screw(M6×6)	1
27	101B-27	A02-27	跳缝齿轮轴环/Skip Stitch Gear Shaft Collar	1
28	101B-28	A02-25	跳缝齿轮轴/Skip Stitch Gear Shaft	1
29	101B-29	LD00001	跳缝齿轮轴螺钉/Screw(M6×10)	1

C、针摆装置及进料装置零部件
Needle Carrier & Feed Dog Mechanism Components

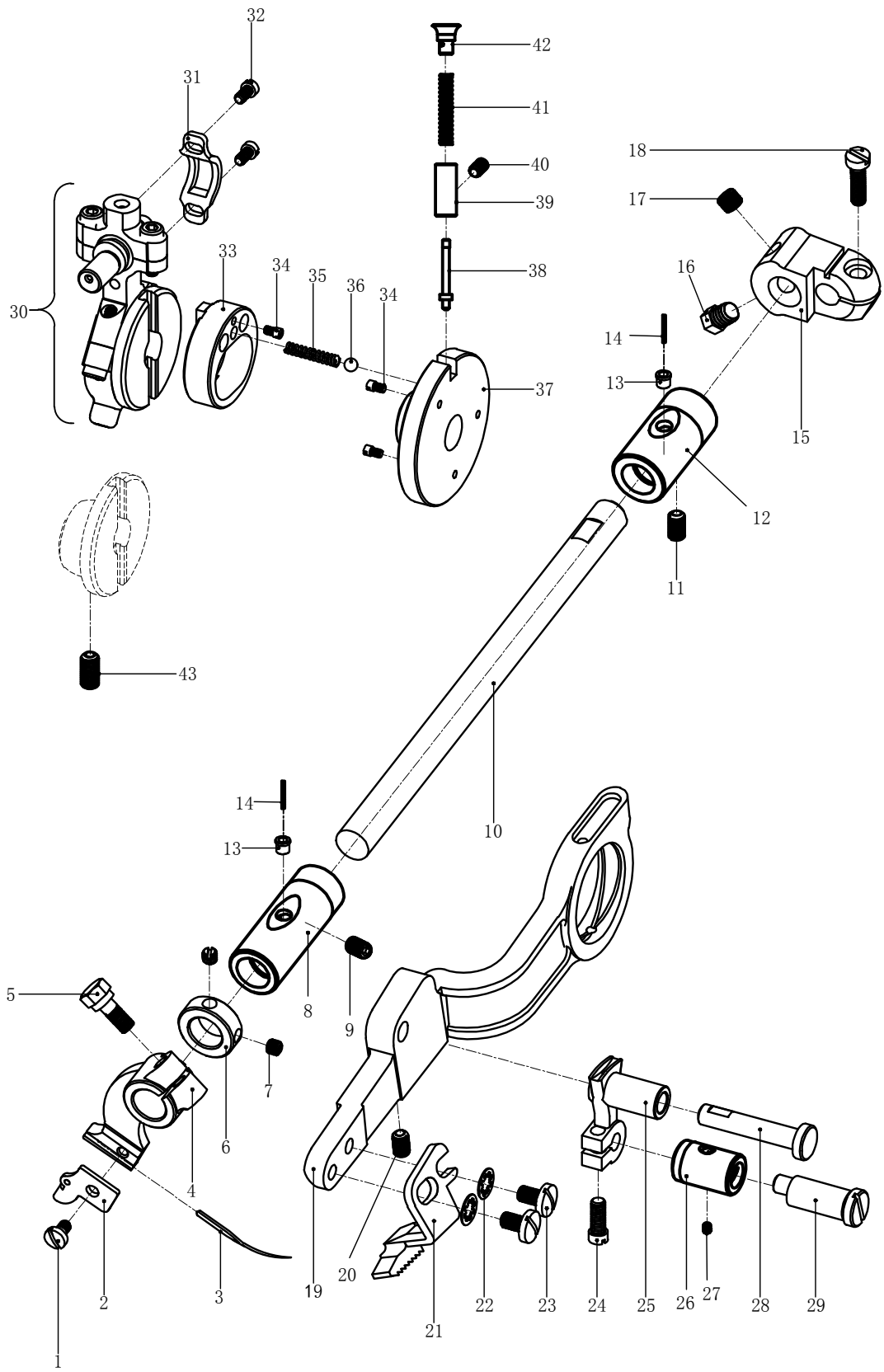

C、针摆装置及进料装置零部件

Needle Carrier & Feed Dog Mechanism Components

序号 Ref.No	代号 Assemble.No	件号 Parts.No	部件名称 Description	数量 Num
1	101C-01	LD00508	针夹螺钉/Screw(9/64-40×7.7)	1
2	101C-02	K3-19	针夹/Needle Clamp	1
3	101C-03	BZ1-13	机针(LW/6T系列)/Needle (System LW × 6T)	1
4	101C-04	A03-03	针摆/Needle Carrier	1
5	101C-05	LD00509	针摆螺钉/Screw(3/16-32×16.5)	1
6	101C-06	A03-06	针轴环/Needle Carrier Shaft Collar	1
7	101C-07	LD00510	针轴环螺钉/Screw(11/64-40×4)	2
8	101C-08	M02-32	针轴前套管/Needle Carrier Shaft Bushing (Front)	1
9	101C-09	LD00099	针轴前套管螺钉/Screw(M5×8)	1
10	101C-10	A03-05	针轴/Needle Carrier Shaft	1
11	101C-11	LD00099	针轴后套管螺钉/Screw(M5×8)	1
12	101C-12	M02-31	针轴后套管/Needle Carrier Shaft Bushing (Rear)	1
13	101C-13	A03-01	油盖/Oil Cap	2
14	101C-14	927C012	油线/Oil Line	2
15	101C-15	A03-12	针轴曲柄/Needle Carrier Shaft Crank	1
16	101C-16	LD00511	针轴曲柄螺钉/Screw(1/4-40×10)	1
17	101C-17	LD00505	针轴曲柄螺钉/Screw(1/4-40×5.2)	1
18	101C-18	LD00512	针轴曲柄夹紧螺钉/Screw(11/64-40×16)	1
19	101C-19	A03-27	进料杆/Feed Lever	1
20	101C-20	LD00099	进料曲柄销子螺钉/Screw(M5×8)	1
21	101C-21	A03-30	牙齿/Feed Dog	1
22	101C-22	DQ00012	牙齿垫圈/Feed Dog Washer	2
23	101C-23	LD00513	牙齿螺钉/Screw(3/16-32×8)	2
24	101C-24	LD00514	送布曲柄销子螺钉/Screw(11/64-40×11)	1
25	101C-25	A03-33-A	送布曲柄/Feed Link	1
26	101C-26	A03-37	进料曲柄套管/Feed Link Eccentric Stud Bushing	1
27	101C-27	LD00083	进料曲柄套管螺钉/Screw(M5X5)	1
28	101C-28	A03-33-B	送布曲柄销子/Feed Stud	1
29	101C-29	A03-36	送料曲柄偏心销/Feed Link Eccentric Stud	1
30	101C-30	A03-18	关节球头组件/Needle Driving Eccentric Assembly	1
31	101C-31	A03-25	球头套盖/Ball Connecting Rod Cap	1
32	101C-32	LD00518	球头套盖螺钉/Screw(1/8-44×6.5)	2
33	101C-33	A03-18-B	偏心套/Spring H	1
34	101C-34	LD00538	缝迹指示器螺钉/Screw(3/32-56×3.3)	3

C、针摆装置及进料装置零部件
Needle Carrier & Feed Dog Mechanism Components

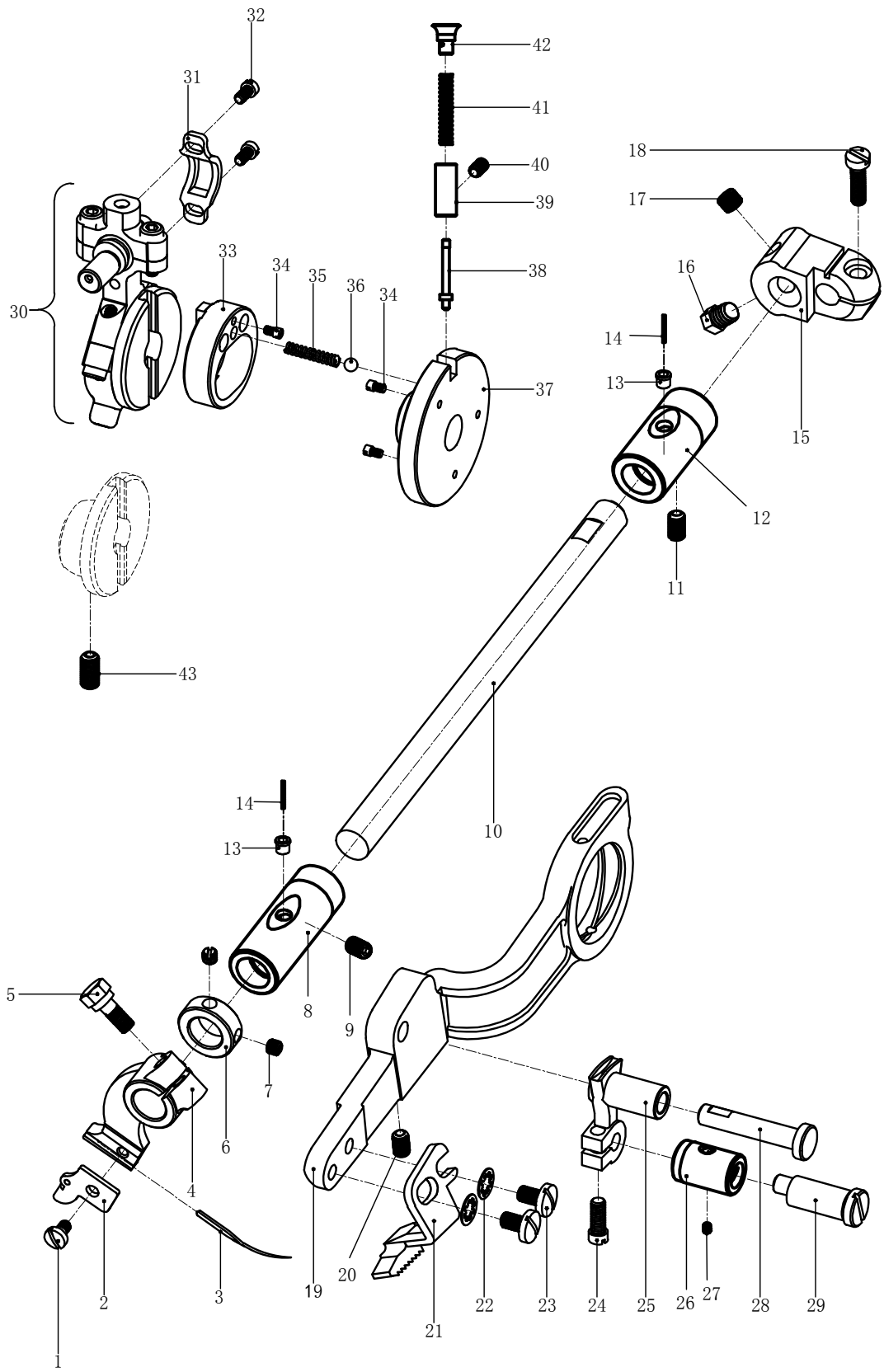

C、针摆装置及进料装置零部件

Needle Carrier & Feed Dog Mechanism Components

序号 Ref.No	代号 Assemble.No	件号 Parts.No	部件名称 Description	数量 Num
35	101C-35	TH00001	缝迹指示器弹簧/Stitch Regulator Spring	1
36	101C-36	GZ00002	缝迹指示器钢珠/Stitch Regulator Ball	1
37	101C-37	A03-18-C	偏心调节盘/Washer 5	1
38	101C-38	A03-39-A	缝迹长度调节活塞销/Piston pin	1
39	101C-39	A03-39	缝迹长度调节活塞套/Piston cover	1
40	101C-40	LD00004	活塞螺钉/Screw(M4×4)	1
41	101C-41	TH00002	缝迹长度调节活塞弹簧/ Piston spring	1
42	101C-42	A03-39-B	缝迹长度调节活塞按钮/Piston button	1
43	101C-43	LD00539	连杆偏心器螺钉/Screw(7/32-32×11)	1

D、打环器装置及针板零部件
 Looper Drive Mechanism & Presser Foot Parts Components

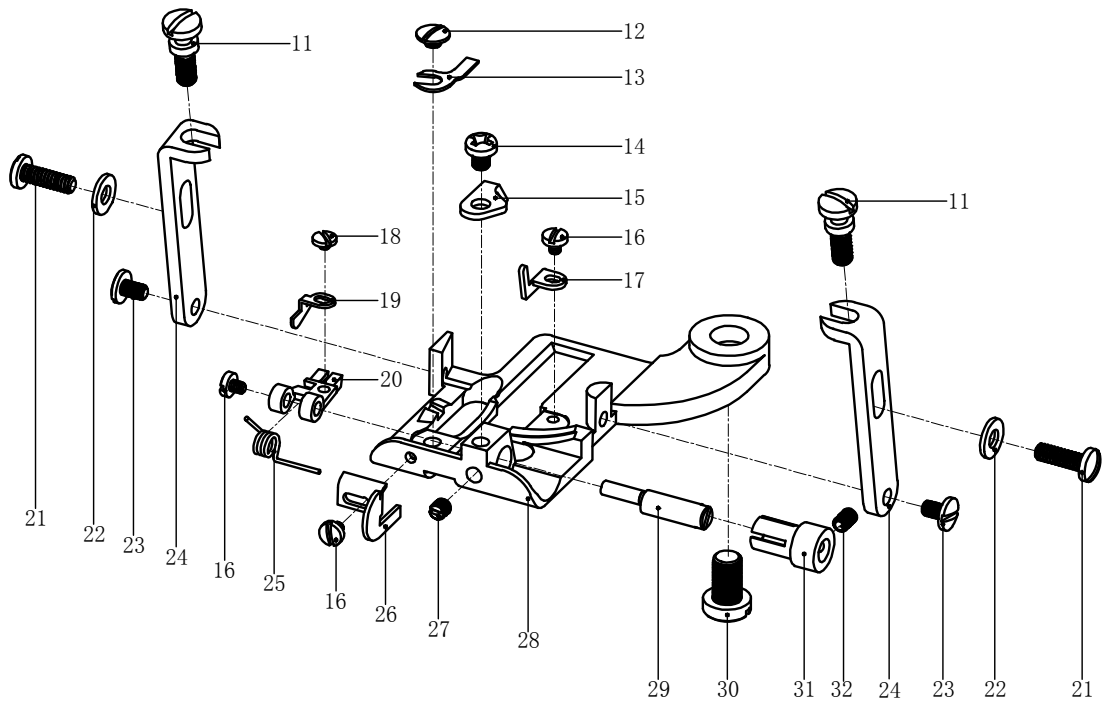
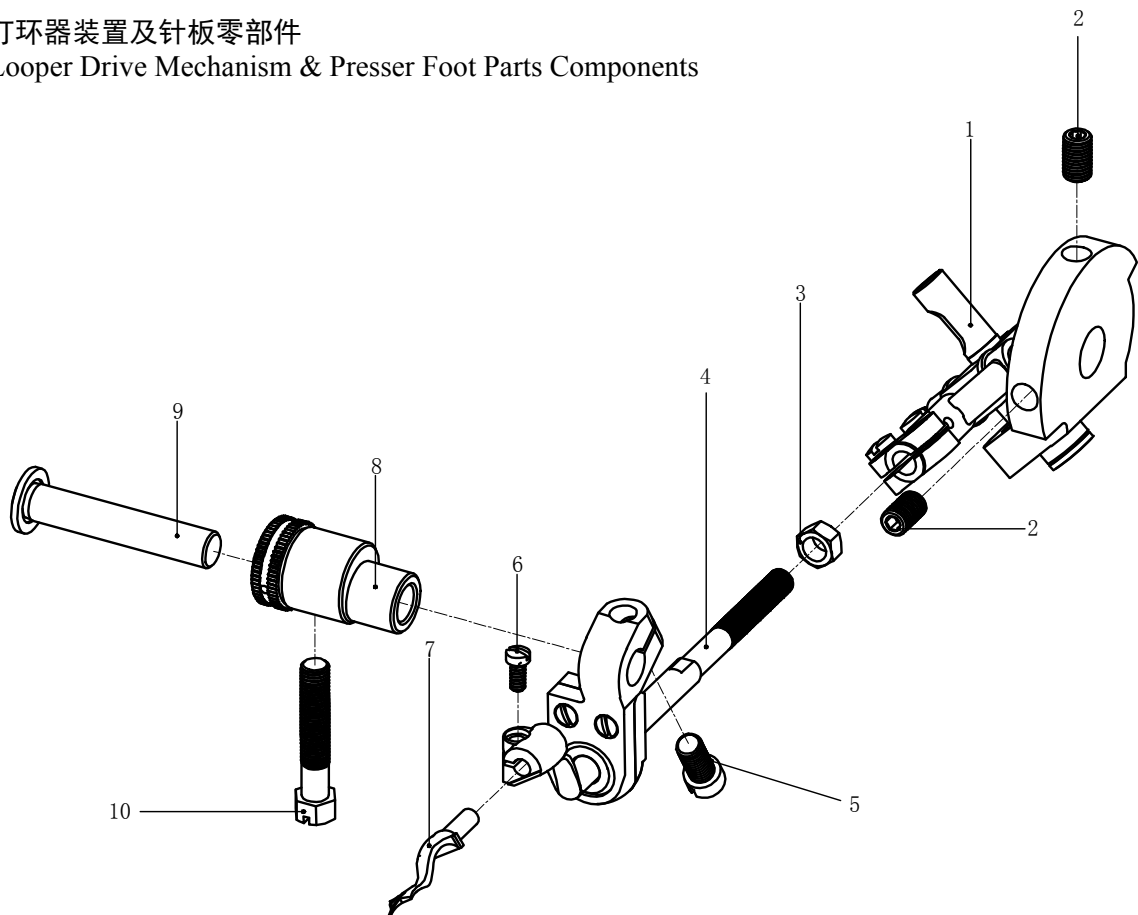

D、打环器装置及针板零部件

Looper Drive Mechanism & Presser Foot Parts Components

序号 Ref.No	代号 Assemble.No	件号 Parts.No	部件名称 Description	数量 Num
1	101D-01	A04-01	打环器曲柄组件/Looper Drive Crank Assembly	1
2	101D-02	LD00063	打环器曲柄组件螺钉/Screw(15/64-28×10)	2
3	101D-03	LM00004	打环器针螺母/Looper Carrier Nut	1
4	101D-04	A04-09-A	打环器针组件/Looper Carrier Assembly	1
5	101D-05	LD00517	打环器轴承夹紧螺钉/Screw(7/32-32×11.5)	1
6	101D-06	LD00518	打环器针夹紧螺钉/Screw(1/8-44×6.5)	1
7	101D-07	K3-32	挑线叉/Looper	1
8	101D-08	A04-17	偏心套筒/Eccentric Sleeve	1
9	101D-09	A04-17-A	偏心销子/Eccentric Pin	1
10	101D-10	LD00519	套筒螺钉/Screw(15/64-28×30)	1
11	101D-11	LD00520	针板支架调节螺钉/Screw(M4×9)	2
12	101D-12	LD00521	导布板螺钉/Screw(9/64-40×2.3)	1
13	101D-13	K3-58	导布板/Stitch Stabilizing Guide	1
14	101D-14	LD00086	定位器螺钉/Screw (9/64-40×4.3)	1
15	101D-15	A04-38	定位器/Cloth Retainer Stopper	1
16	101D-16	LD00522	链指针螺钉/Screw(3/32-56×2.5)	3
17	101D-17	K3-56	链指针/Chainging Finger	1
18	101D-18	LD00065	压布板导布片螺钉/Screw(3/32-56×2)	1
19	101D-19	K3-62-1	压布板导布片/Fixture plate guide sheet	1
20	101D-20	K3-62	压布板/Cloth Retainer	1
21	101D-21	LD00280	针板支架夹紧螺钉/Screw(9/64-40×11.5)	2
22	101D-22	DQ00005	针板支架垫圈/Washer	2
23	101D-23	LD00523	针板夹紧螺钉/Screw(1/8-44×5.2)	2
24	101D-24	K3-48	针板支架/Presser Foot Bracket	2
25	101D-25	A04-33	压布板弹簧/Cloth Retainer Spring	1
26	101D-26	K3-60	引边装置/Edge Guide	1
27	101D-27	LD00524	压布板销锁紧螺钉/Screw(9/64-40×4)	1
28	101D-28	A04-26	针板/Needle Guide	1
29	101D-29	A04-34	压布板偏心销/Cloth Retainer Eccentric Stud	1
30	101D-30	LD00525	针板螺钉/Screw(15/64-28×10)	1
31	101D-31	K3-67	压布板偏心套筒/Cloth Retainer Eccentric Stud Bushing	1
32	101D-32	LD00040	压布板偏心销螺钉/Screw(M3×3)	1

E、起菱盘及进料板机械零部件
Ridge Forming Disc & Feed Plate Mechanism Components

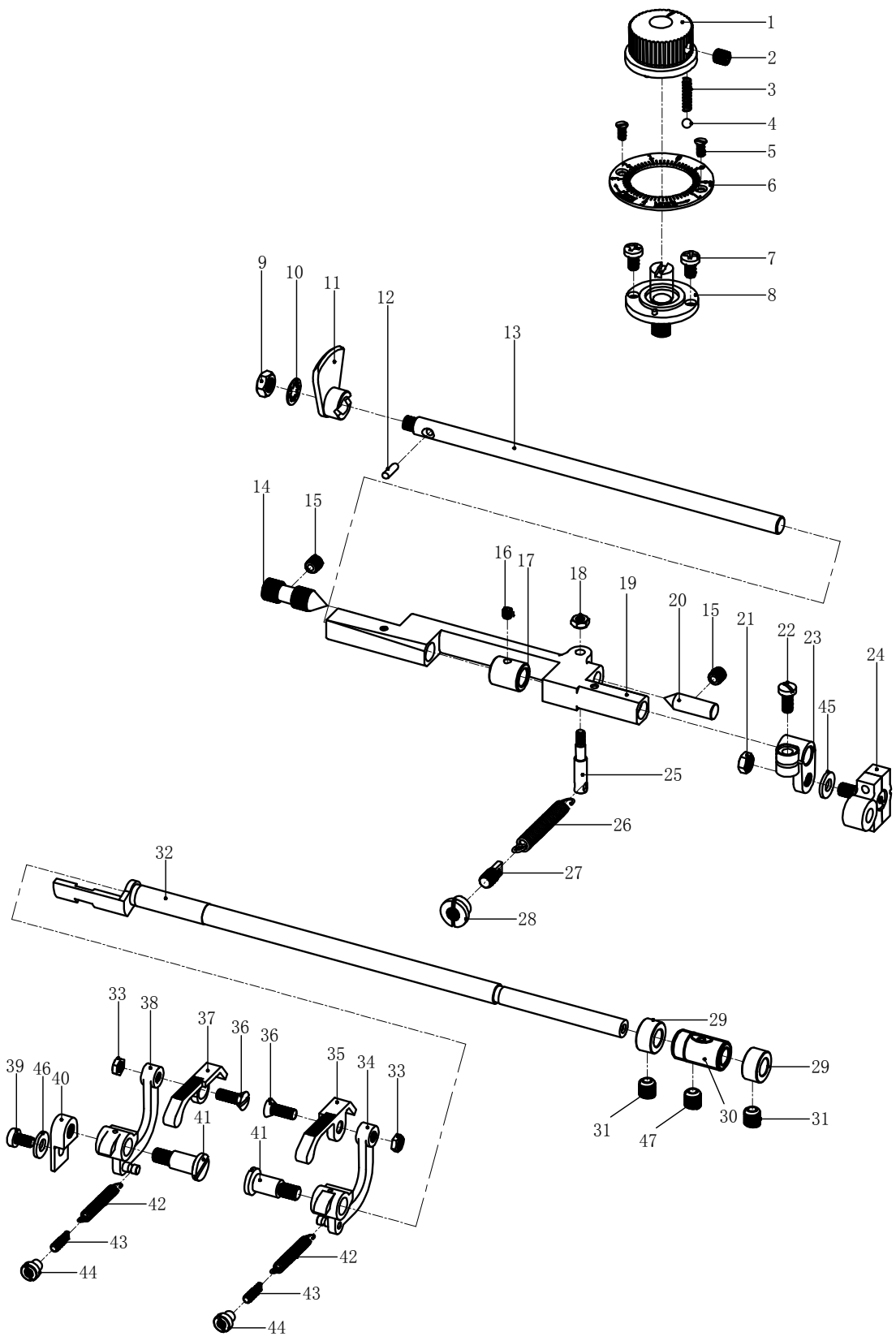

E、起菱盘及进料板机械零部件

Ridge Forming Disc & Feed Plate Mechanism Components

序号 Ref.No	代号 Assemble.No	件号 Parts.No	部件名称 Description	数量 Num
1	101E-01	A05-39	起菱盘调节器/Disc Adjusting Regulator Assembly	1
2	101E-02	LD00003	调节器固定螺钉/Screw(M6×6)	1
3	101E-03	TH00005	调节弹簧/Disc Adjusting Regulator Spring	1
4	101E-04	GZ00001	钢球/Disc Adjusting Regulator Ball	1
5	101E-05	LD00342	调节显示牌螺钉/Screw(1/8-44×7)	2
6	101E-06	A05-37	调节显示牌/Disc Adjusting Dial	1
7	101E-07	LD00518	调节基座螺钉/Screw(1/8-44×6.5)	2
8	101E-08	A05-45	调节基座/Disc Adjusting Regulator Base	1
9	101E-09	LM00002	起菱盘螺母/Ridge Forming Disc Nut	1
10	101E-10	DQ00006	起菱盘垫圈/Ridge Forming Disc Washer	1
11	101E-11	A05-01	起菱盘/Ridge Forming Disc	1
12	101E-12	A05-04	起菱盘档销/Ridge Forming Disc Positioning Pin	1
13	101E-13	A05-05	起菱盘轴/Ridge Forming Disc Shaft	1
14	101E-14	A05-14	调节柄调节螺钉/Screw	1
15	101E-15	LD00003	调节柄轴固定螺钉/Screw(M6×6)	1
16	101E-16	LD00004	起菱盘曲柄螺钉/Screw(M4×4)	1
17	101E-17	A05-06	起菱盘轴环/Ridge Forming Disc Shaft Collar	1
18	101E-18	LM00007	调节柄弹簧拉销螺母/ Nut	1
19	101E-19	A05-13	起菱盘调节柄/Disc Adjusting Holder	1
20	101E-20	A05-16	调节柄锥度销/Disc Adjusting Holder Pivot Bearing Pin	1
21	101E-21	LM00004	球头固定螺母/Ball Stud Nut	1
22	101E-22	LD00503	起菱盘曲柄螺钉/Screw(11/64-40×10)	1
23	101E-23	A05-08	起菱盘曲柄/Ridge Forming Disc Shaft Crank	1
24	101E-24	A05-10	球形接头和螺钉/Ball Joint& Stud Assembly With Screws	1
25	101E-25	A05-21	调节柄弹簧拉销/Disc Adjusting Holder Spring Stud	1
26	101E-26	TH00003	调节柄弹簧/Disc Adjusting Holder Spring	1
27	101E-27	A05-19	调节柄弹簧螺钉/Disc Adjusting Holder Spring Screw	1
28	101E-28	A05-20	调节柄弹簧螺母/Disc Adjusting Holder Spring Nut	1
29	101E-29	A05-26	抬压脚轴轴环/Feed Plate Shaft Collar	2
30	101E-30	A05-24	抬压脚轴套管/Feed Plate Shaft Bushing	1
31	101E-31	LD00004	抬压脚轴轴环螺钉/Screw(M4×4)	2
32	101E-32	A05-23	抬压脚轴/Feed Plate Shaft	1
33	101E-33	LM00001	压脚螺母/Feed Plate Nut	2
34	101E-34	A05-28-B	右压脚支架/Cylinder bed shaft sleeve	1

E、起菱盘及进料板机械零部件
Ridge Forming Disc & Feed Plate Mechanism Components

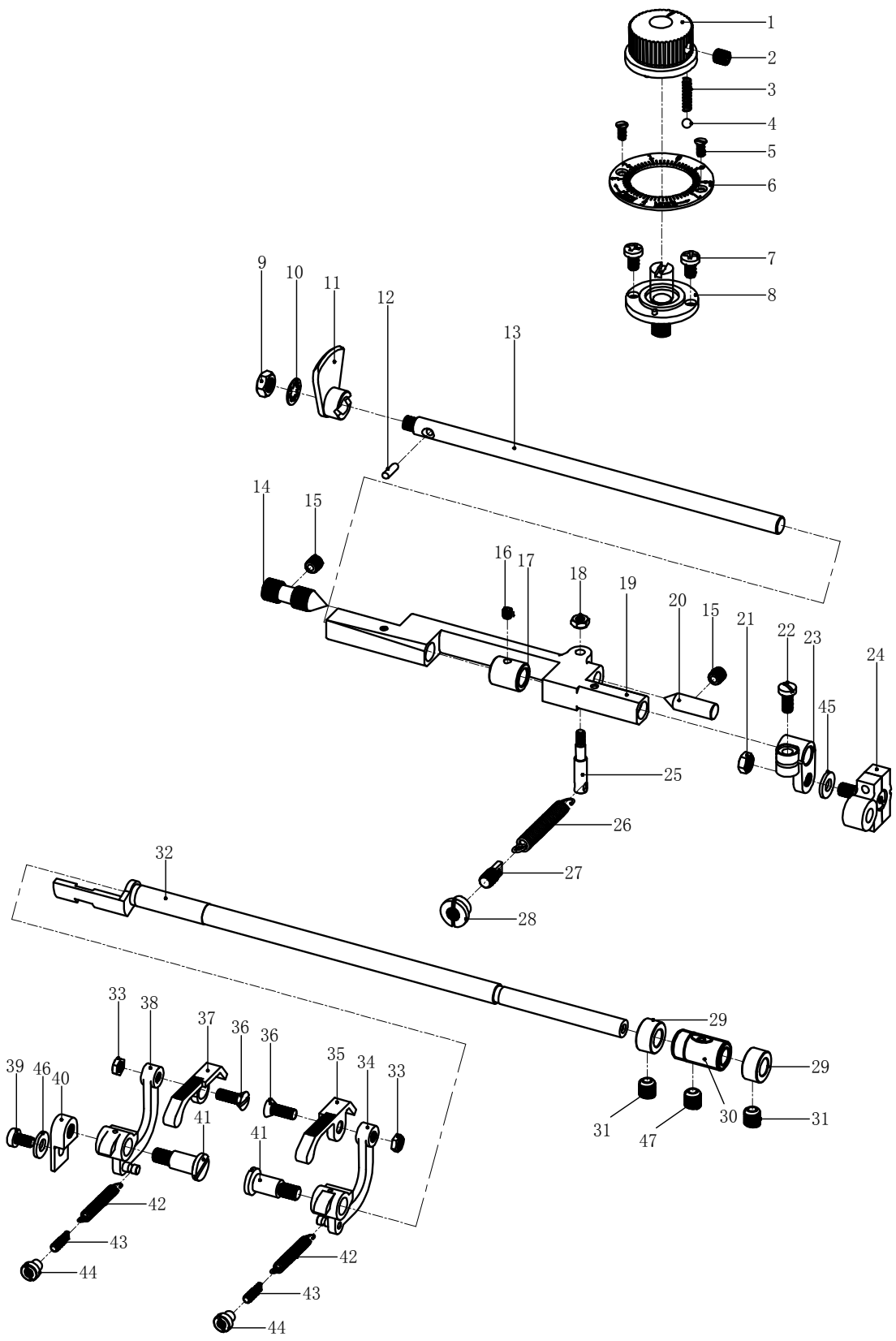

E、起菱盘及进料板机械零部件

Ridge Forming Disc & Feed Plate Mechanism Components

序号 Ref.No	代号 Assemble.No	件号 Parts.No	部件名称 Description	数量 Num
35	101E-35	A05-28-D	右压脚/Cylinder bed shaft	1
36	101E-36	LD00527	压脚螺钉/Screw(11/64-40×15)	2
37	101E-37	A05-28	左压脚/Stopper ring	1
38	101E-38	A05-28-A	左压脚支架/Spring L	1
39	101E-39	LD00010	托架螺钉/Screw(11/64-40×11)	1
40	101E-40	A05-35	压脚托架/Feed Plate Bracket	1
41	101E-41	A05-31	压脚轴位螺钉/Feed Plate Shoulder Bearing Screw	2
42	101E-42	TH00004	压脚拉簧/Feed Plate Spring	2
43	101E-43	A05-33	压脚拉簧螺钉/Feed Plate Spring Screw	2
44	101E-44	A05-34	压脚拉簧螺母/Feed Plate Spring Adjusting Nut	2
45	101E-45	DQ00014	弹簧垫片/Spring Shim	1
46	101E-46	DQ00026	垫圈/Washer	1
47	101E-47	LD00001	抬压脚轴套头螺钉/Screw(M6×10)	1

F、起菱盘摆动装置及机杆零部件
 Disc Oscillating Mechanism & Knee Press Shaft Parts Components

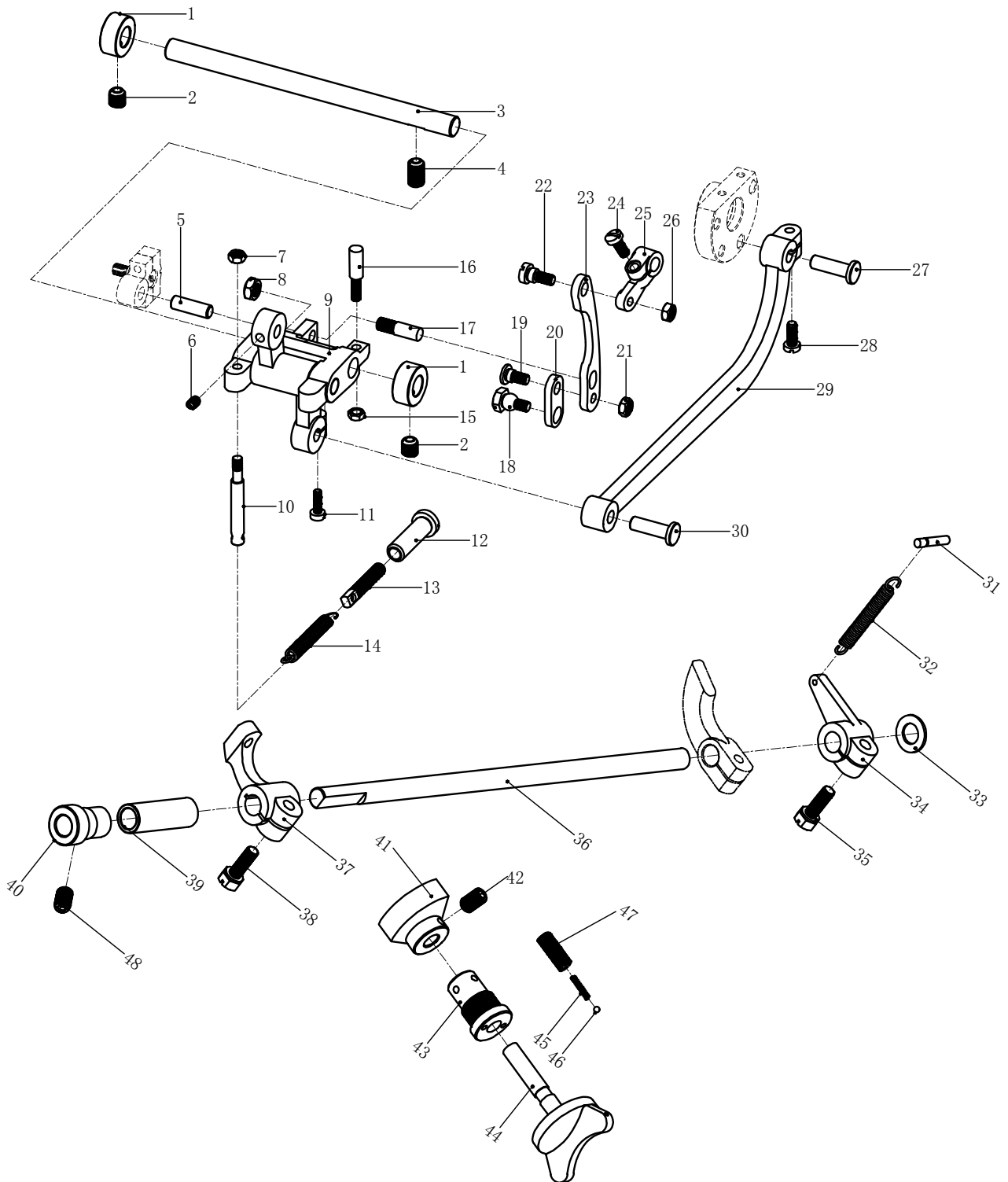

F、起菱盘摆动装置及机杆零部件

Disc Oscillating Mechanism & Knee Press Shaft Parts Components

序号 Ref.No	代号 Assemble.No	件号 Oarts.No	部件名称 Description	数量 Num
1	101F-01	K2-20	托架轴环/Disc Oscillating Rod Bracket Shaft Collar	2
2	101F-02	LD00003	托架轴环螺钉/Screw(M6×6)	2
3	101F-03	A06-15	托架轴/Disc Oscillating Rod Bracket Shaft	1
4	101F-04	LD00001	托架轴螺钉/Screw(M6×10)	1
5	101F-05	A06-09	摆杆销1/Disc Oscillating Rod Pin	1
6	101F-06	LD00178	摆杆销螺钉Screw(11/64-40×3.2)	1
7	101F-07	LM00001	弹簧栓螺母/Nut	1
8	101F-08	LM00002	连接杆螺母/Connecting Link Guide Screw Nut	1
9	101F-09	A06-07	摆杆/Disc Oscillating Rod Assembly	1
10	101F-10	A06-13	托架弹簧栓/Disc Oscillating Rod Bracket Spring Stud	1
11	101F-11	LD00528	摆杆销螺钉/Screw(9/64-40×12)	1
12	101F-12	A06-03	弹簧螺母/Disc Oscillating Rod Bracket Spring Nut	1
13	101F-13	A06-02	弹簧螺钉/Disc Oscillating Rod Bracket Spring Screw	1
14	101F-14	TH00006	摆杆托架弹簧/Disc Oscillating Rod Bracket Spring	1
15	101F-15	LM00001	凸轮螺母/Skip-Stitch Seleecting Cam Stud Nut	1
16	101F-16	A06-51	凸轮连接螺钉/Skip-Stitch Seleecting Cam Stud	1
17	101F-17	A06-24	连接杆螺钉/Connecting Link Guide Screw	1
18	101F-18	A06-31	托架连接螺钉/Crank & Link Shoulder Screw	1
19	101F-19	A06-29	小连接杆螺钉/Connecting Link Set Screw	1
20	101F-20	A06-28	小连接杆/Connecting Link (small)	1
21	101F-21	LM00008	小连接杆螺母/Connecting Link Set Screw Nut	1
22	101F-22	A06-21	曲柄轴位螺钉/Crank & Link Shoulder Screw	1
23	101F-23	A06-23	连接杆/Connecting Link (Large)	1
24	101F-24	LD00512	进料板曲柄螺钉/Screw(9/64-40×16)	1
25	101F-25	A06-19	进料板曲柄/Feed Plate Depressing Crank	1
26	101F-26	LM00008	小连接杆螺母/Connecting Link Set Screw Nut	1
27	101F-27	A06-05	连杆销/Connecting Rod Stud	1
28	101F-28	LD00503	连杆销螺钉/Screw(11/64-40×10)	1
29	101F-29	A06-04	连杆/Connecting Rod	1
30	101F-30	A06-11	摆杆销2/Disc Oscillating Rod Stud	1
31	101F-31	A06-41	限位连杆弹簧螺钉/Knee Press Stop Lever Clamp Screw	1
32	101F-32	TH00007	限位连杆弹簧/Knee Press Stop Lever Spring	1
33	101F-33	DQ00009	机轴垫圈/Knee Press Shaft Washer	1
34	101F-34	A06-38	限位连杆/Knee Press Stop Lever	1

F、起菱盘摆动装置及机杆零部件

Disc Oscillating Mechanism & Knee Press Shaft Parts Components

序号 Ref.No	代号 Assemble.No	件号 Oarts.No	部件名称 Description	数量 Num
35	101F-35	LD00529	限位连杆螺钉/Screw(15/64-28×17)	1
36	101F-36	A06-36	机轴/Knee Press Shaft	1
37	101F-37	A06-26	机轴托架/Knee Press Shaft Crank	1
38	101F-38	LD00529	机轴托架螺钉/Screw(15/64-28×17)	1
39	101F-39	A06-35	机轴套管/Knee Press Shaft Sleeve	1
40	101F-40	A06-32	机轴套管/Knee Press Shaft Bushing	1
41	101F-41	A06-49	跳缝拉杆凸轮/Skip-Stitch Selecting Cam	1
42	101F-42	LD00099	凸轮螺钉/Screw(M5×8)	1
43	101F-43	A06-48	跳缝拉杆套管/Skip-Stitch Selecting Grip Bushing	1
44	101F-44	A06-44	跳缝拉杆/Skip-Stitch Selecting Grip	1
45	101F-45	TH00001	跳缝拉杆弹簧/Skip-Stitch Selecting Spring	1
46	101F-46	GZ00002	钢珠/Skip-Stitch Selecting Ball	1
47	101F-47	A06-47	跳缝拉杆螺钉/Skip-Stitch Selecting Spring Holder	1
48	101F-48	LD00003	螺钉/Screw(M6×6)	1

G、压线装置零部件
Thread Tension & Nipper Parts Components

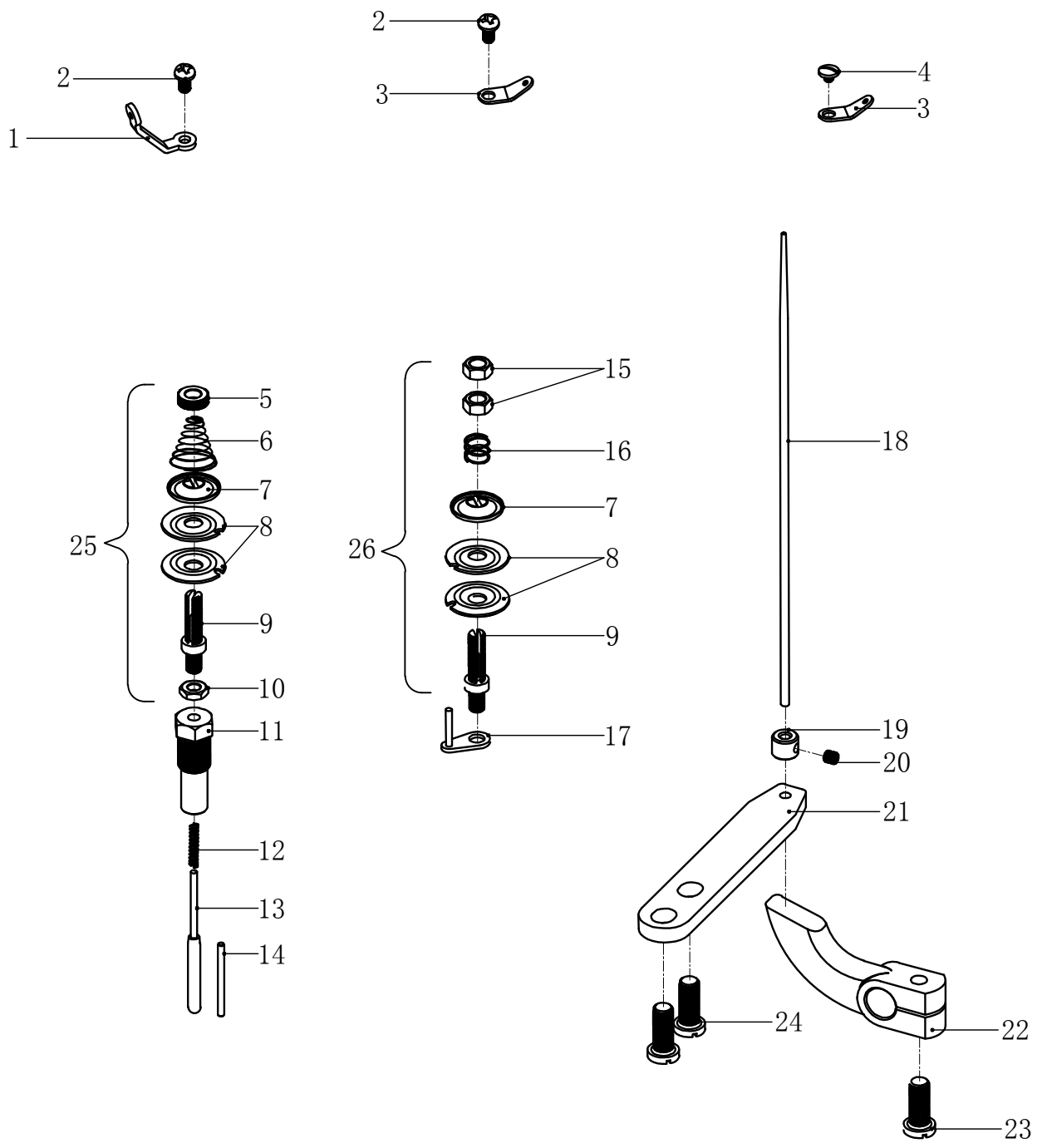

G、压线装置零部件

Thread Tension & Nipper Parts Components

序号 Ref.No	代号 Assemble.No	件号 Parts.No	部件名称 Description	数量 Num
1	101G-01	A07-01-A	引线装置/Thread Guide With Ceramic	1
2	101G-02	LD00010	引线装置螺钉/Screw(11/64-40×8)	2
3	101G-03	A07-12	引线装置/Thread Guide	2
4	101G-04	LD00530	引线装置螺钉/Screw(11/64-40×3)	1
5	101G-05	K1-29	压线螺母/Thread Tension Nut	2
6	101G-06	K1-28-B	压线弹簧/Thread Tension Spring	1
7	101G-07	A07-05	压线垫圈/Thread Tension Washer	2
8	101G-08	A07-06	压线板/Thread Tension Disc	4
9	101G-09	A07-08	压线杆/Thread Tension Staff	2
10	101G-10	LM00002	压线杆螺母/Thread Tension Staff Nut	1
11	101G-11	A07-10	压线杆螺母/Thread Tension Staff Bracket	1
12	101G-12	TH00038	夹线器弹簧/Belt Guard Spring	1
13	101G-13	A07-11	线迹松紧销/Thread Tension Releasing Pin	1
14	101G-14	A07-07	压线板挡销/Thread Tension Disc Pin	1
15	101G-15	LM00010	夹线螺母/Thread Nipper Nut	2
16	101G-16	A07-15	夹线弹簧/Thread Nipper Spring	1
17	101G-17	A07-19	线夹支柱/Thread Nipper Disc Prop	1
18	101G-18	A07-20	线夹松紧柱/Thread Nipper Releasing Pin	1
19	101G-19	A07-21	线夹松紧套筒/Thread Nipper Releasing Pin Collar	1
20	101G-20	LD00524	松紧套筒螺钉/Screw(9/64-40×4)	1
21	101G-21	A07-23	线夹松紧支柱/Thread Nipper Releasing Pin Support	1
22	101G-22	A07-25	线夹松紧钉杆/Thread Nipper Releasing Pin Lever	1
23	101G-23	LD00533	线夹松紧钉杆螺钉/Screw(15/64-28×15)	1
24	101G-24	LD00532	松紧钉支柱螺钉/Screw(15/64-28×10.8)	2
25	101G-25	A07-03/ZJ	压线杆组件/Press Pole Components	1
26	101G-26	A07-14/ZJ	线夹组件/Wire Clip Component	1

H、操作板，压杆及皮带部位的零部件
Work Plate , Knee Press & Belt Cover Parts Components

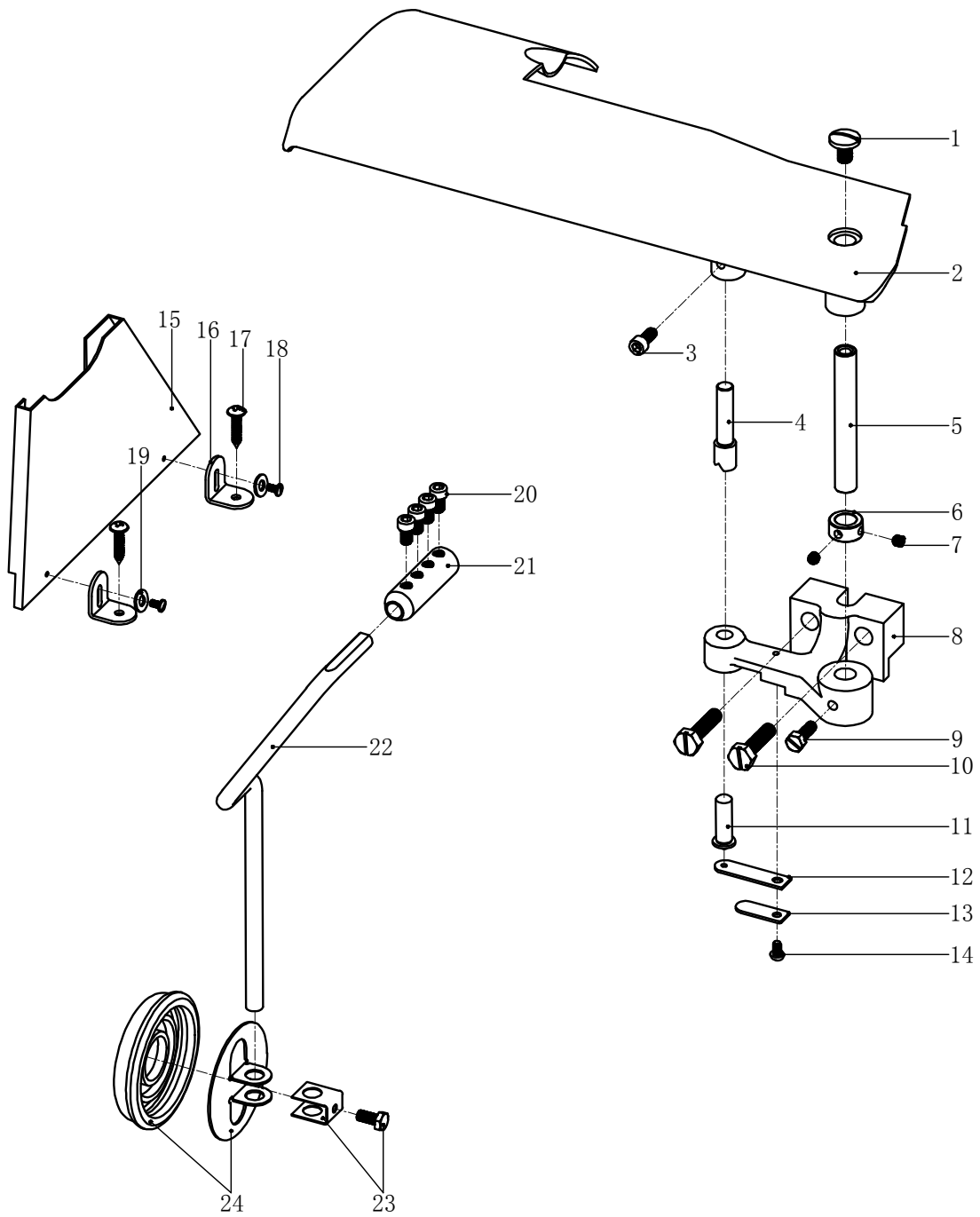

H、操作板，压杆及皮带部位的零部件
Work Plate , Knee Press & Belt Cover Parts Components

序号 Ref.No	代号 Assemble.No	件号 Parts.No	部件名称 Description	数量 Num
1	101H-01	LD00534	面板螺钉/Screw(5/16-24×13)	1
2	101H-02	A08-01	面板/Work Plate	1
3	101H-03	LD00535	面板固定销螺钉/Screw(M6×14)	1
4	101H-04	A08-02	面板固定销/Work Plate Latch	1
5	101H-05	A08-10	面板轴/Work Plate Shaft	1
6	101H-06	A08-12	面板轴套筒/Work Plate Shaft Collar	1
7	101H-07	LD00003	套筒螺钉/Screw(M6×6)	2
8	101H-08	A08-04	面板支架/Work Plate Bracket	1
9	101H-09	LD00529	面板轴螺钉/Screw(15/64-28×17)	1
10	101H-10	LD00536	面板支架固定螺钉/Screw(5/16-24×32)	2
11	101H-11	A08-05	面板支架弹簧销/Work Plate Bracket Spring Pin	1
12	101H-12	A08-06	面板支架长弹簧片/Work Plate Bracket Leaf Spring (long)	1
13	101H-13	A08-07	面板支架短弹簧片/Work Plate Bracket Leaf Spring (short)	1
14	101H-14	LD00010	螺钉/Screw (11/64-40×8)	1
15	101H-15	A01-09	皮带罩/Belt Cover	1
16	101H-16	A08-22	皮带罩托架/Belt Cover Bracket	2
17	101H-17	F j8-15-1	皮带罩木螺钉/Belt Cover Wood Screw	2
18	101H-18	LD00537	皮带罩托架螺钉/Screw(9/64-40×7)	2
19	101H-19	DQ00005	针板支架垫圈/Spring Washer	2
20	101H-20	LD00418	压杆套筒螺钉/Screw(M6×10)	4
21	101H-21	F J9-15	压杆套筒/Work Press Rod Sleeve	1
22	101H-22	F J7-21	压杆/Knee Press Rod	1
23	101H-23	F J7-26	压板组件/Clamp Component	1
24	101H-24	F J7-22	靠膝橡皮/By Knee Rubber	1

I、标准附件
Standard Accessories

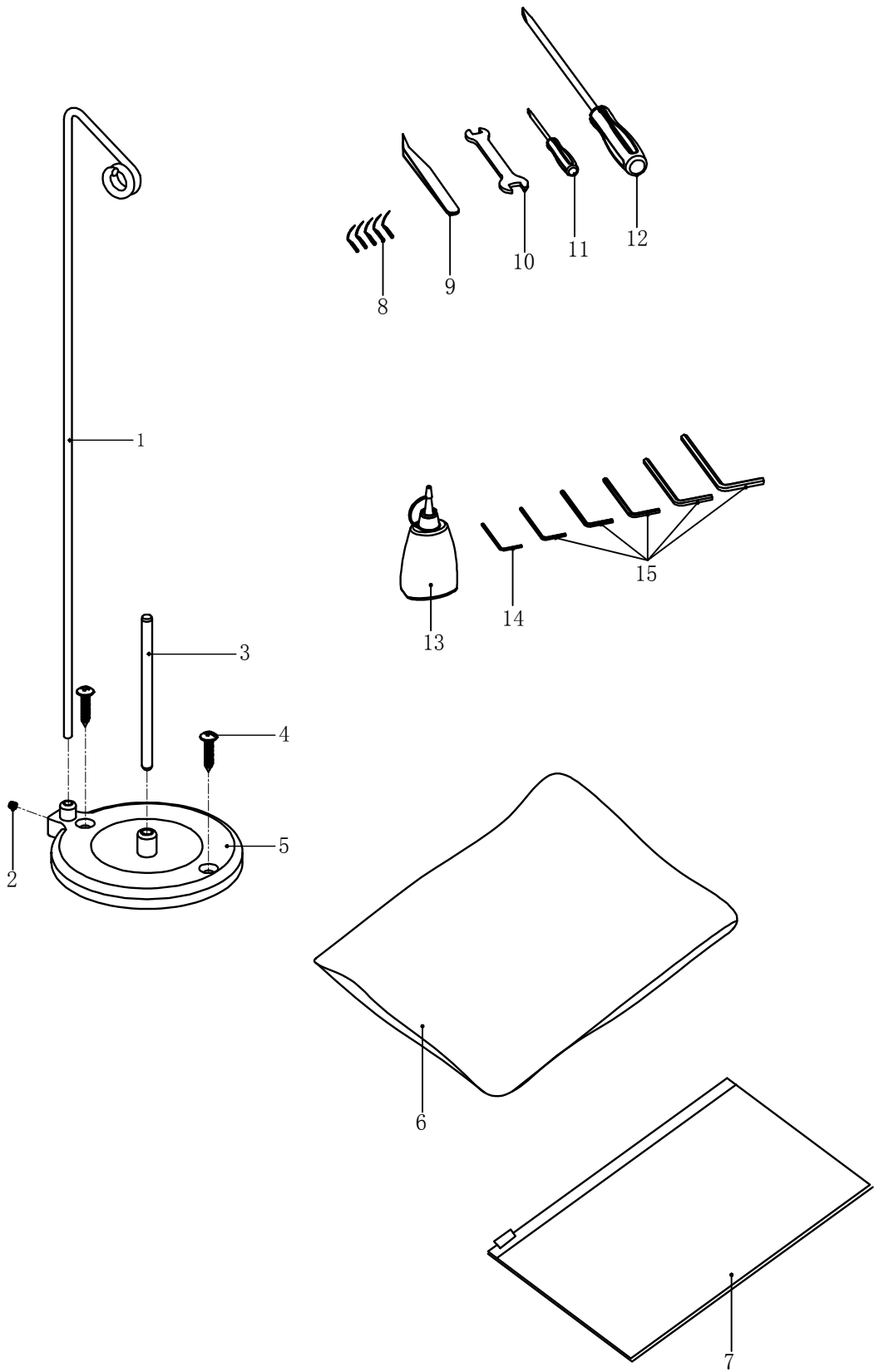

I、标准附件

Standard Accessories

序号 Ref.No	代号 Assemble.No	件号 Parts.No	部件名称 Description	数量 Num
1	101I-01	F J4-15	引线装置/Thread Guide	1
2	101I-02	LD00004	引线装置螺钉/Screw(M4×4)	1
3	101I-03	F J1-40	线轴销/Spool Pin	1
4	101I-04	F J1-16	线底座木螺钉/Cotton Stand Base Wood Screw	2
5	101I-05	F J4-15-1	线轴底座/Cotton Stand Base	1
6	101I-06	F J9-3	套机袋/Belt Guard Nut	1
7	101I-07	F J-D-12	工具袋/Belt Guard Screw	1
8	101I-08	BZ1-13	机针 (11 LWX6T) /Needle(System 11 LWX6T)	1
9	101I-09	F J4-8	镊子/Side Bar Bolt M4	1
10	101I-10	F J4-3	呆扳手/Side Bar	1
11	101I-11	F J8-8	螺丝刀 (小) /Screw Driver (Small)	1
12	101I-12	F J8-6	螺丝刀 (大) /Screw Driver (Large)	1
13	101I-13	F J7-28	小油壶/Rubber Cushion	1
14	101I-14	F J4-10	内六角扳手1.5/Machine Frame Set Washer	1
15	101I-15	F J4-11	内六角扳手2-5/Machine Frame Set Washer	1

J、型号CM-101-H附加零部件
Work Plate , Knee Press & Belt Cover Parts Components

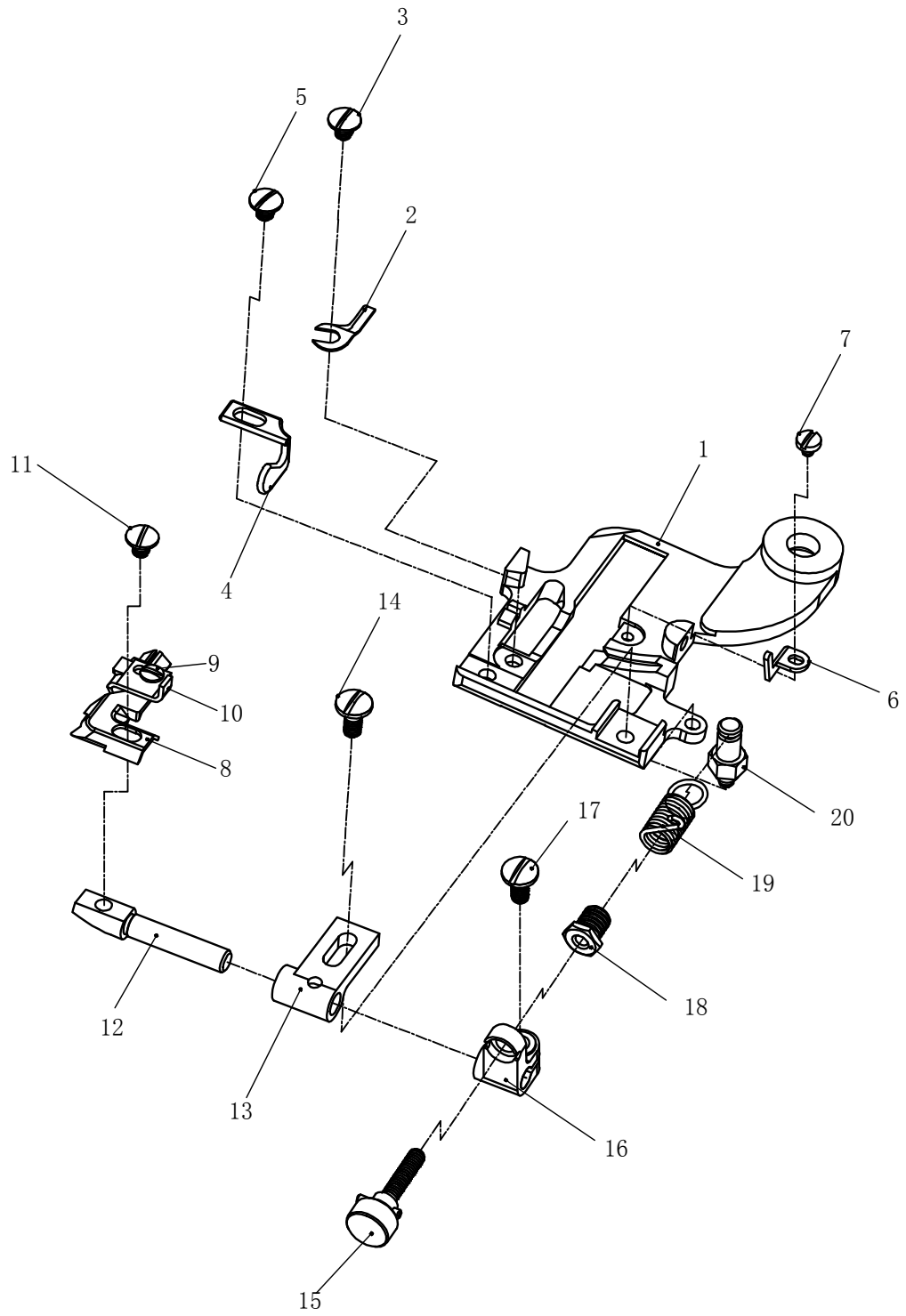

J、型号CM-101-H附加零部件

Work Plate , Knee Press & Belt Cover Parts Components

序号 Ref.No	代号 Assemble.No	件号 Parts.No	部件名称 Description	数量 Num
1	101J-01	H4-26	针板/Needle Guide	1
2	101J-02	K3-58	导布板/Stitch Stabilizing Guide	1
3	101J-03	LD00521	导布板螺钉/Screw(9/64-40×2.3)	1
4	101J-04	A11-05	引边装置/Edge Guide	1
5	101J-05	LD00540	引边装置螺钉/Screw(9/64-40×2.3)	1
6	101J-06	K3-56	链指针/Chaining Finger	1
7	101J-07	LD00522	链指针螺钉/Screw(3/32-56×2.5)	1
8	101J-08	E11-07	挡料挡板/Cloth Retainer	1
9	101J-09	LD00522	螺钉/Screw(3/32-56×2.5)	1
10	101J-10	E11-07	挡料挡板/Cloth Retainer	1
11	101J-11	LD00540	挡料挡板螺钉/Screw(9/64-40×2.3)	1
12	101J-12	A11-09	布料挡板柄/Cloth Retainer Holer	1
13	101J-13	A11-10	布料挡板托架/Cloth Retainer Bracket	1
14	101J-14	LD00541	布料挡板托架螺钉/Screw(M10×25)	1
15	101J-15	A11-13	布料挡板弹簧调整螺钉/Screw	1
16	101J-16	A11-14	弹簧调整螺钉支柱/Cloth Retainer Spring Adjusting Screw Prop	1
17	101J-17	LD00508	支柱螺钉/Screw(9/64-40×7.7)	1
18	101J-18	A11-16	布料挡板弹簧套管/Cloth Retainer Spring Bushing	1
19	101J-19	A11-12	布料挡板弹簧/Cloth Retainer Spring	1
20	101J-20	A11-17	布料挡板弹簧钉/Cloth Retainer Spring Pin	1