

CONTENS

◆ INSTRUCTION MANUAL

1. SPECIFICATIONS	1
2. INSTALLATION	1
3. ADJUSTING THE HEIGHT OF THE KNEE LIFTER	2
4. INSTALLING THE THREAD STAND	3
5. LUBRICATE	3
6. LUBRICATION	3
7. ADJUSTING THE AMOUNT OF OIL(OIL SPLASHES) IN THE HOOK	4
8. ATTACHING THE NEEDLE.....	5
9. SETTING THE BOBBIN INTO THE BOBBIN CASE	6
10. ADJUSTING THE STITCH LENGTH	6
11. PRESSER FOOT PRESSURE	6
12. HAND LIFTER	6
13. ADJUSTING THE HEIGHT OF THE PRESSER BAR	7
14. THREADING THE MACHINE HEAD	7
15. THREAD TENSION	8
16. THREAD TAKE-UP SPRING	8
17. ADJUSTING THE THREAD TAKE-UP STROKE	9
18. NEEDLE-TO-HOOK RELATIONSHIP	9
19. HEIGHT OF THE FEED DOG	10
20. TILT OF THE FEED DOG	11
21. ADJUSTING THE FEED TIMING	11
22. ADJUSTING THE NEEDLE STOP POSTION	12
23. COUNTER KNIFE	13
24. PEDAL PRESSURE AND PEDAL STOKE.....	14
25. ADJUSTMENT OF THE PEDAL.....	14
26. PEDAL OPERATION.....	15
27. ONE-TOUCH TYPE REVERSE FEED,STITCHIN MECHANISM.....	15
28. WIPER.....	16

◆ PARTS BOOK

1. MACHINE FRAME&MISCELLANEOUS COVER COMPONENTS	18-21
2. MAIN SHAFT&THREAD-UP LEVER COMPONENTS	22-23
3. IMPACT CONTROLLER SYSTEM	22-23
4. NEEDLE BAR,UPRIGHT SHAFT&HOOK DRIVING SHAFT COMPONENTS	24-25
5. HAND LIFTER COMPONENTS	26-27
6. FEED MECHANISM COMPONENTS	28-31
7. THREAD TRIMMER COMPONENTS	32-33
8. AUTOMATIC REVERSE FEED COMPONENTS	34-35
9. WIPER COMPONENTS.....	34-35
10. OIL LUBLICATION COMPONENTS	36-37
11. OIL RESERVOIR COMPONENTS	36-37
12. THREAD STAND COMPONENTS	38-39
13. ACCESSORIES	38-39

1. 规格 / SPECIFICATIONS

	标准型	薄料型	厚料型
用途	一般布料、薄料、中厚料	一般布料、薄料	中厚料、厚料
缝纫速度	最高4500 rpm	最高4000 rpm	最高3500 rpm
最大针脚长度	4mm		5mm
机针	DB x 1 #9~#11	DA x 1 #9~#11	DB x 1 #20~#23
压脚高度(膝动提升)	10mm(标准) 13mm(最大)	9mm(最大)	10mm(标准) 13mm(最大)
使用机油	NO.10白油		

	Medium-weight model	Light-weight model	Heavy-weight model
Application	General fabrics, light-weight and medium-weight materials.	General fabrics, light-weight materials.	Medium-weight materials, heavy-weight materials.
Sewing speed	Max. 4500 rpm	Max. 4000 rpm	Max. 3500 rpm
Max. stitch length	4mm		5mm
Needle	DB x 1 #9~#11	DA x 1 #9~#11	DB x 1 #20~#23
Presser foot lift	10mm(standard) 13mm(Max.)	9mm(Max.)	10mm(standard) 13mm(Max.)
Lubricating oil	Defrix Oil NO.10		

2. 缝纫机的安装 / INSTALLATION

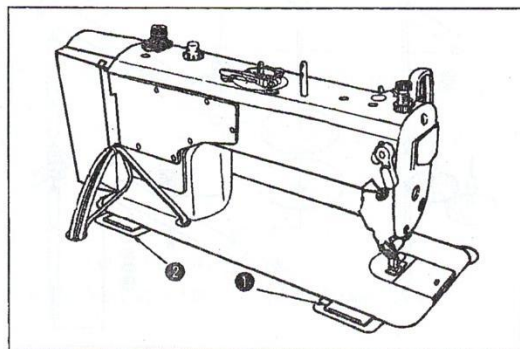
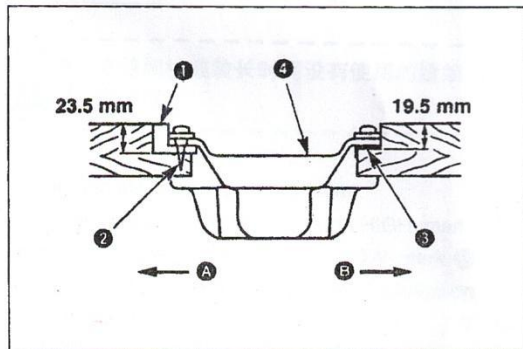
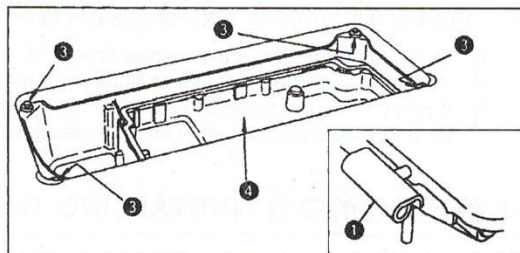
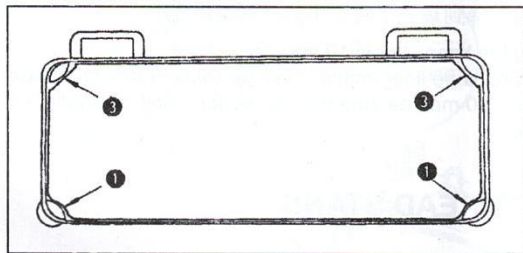

(1) 底槽的安装

- 1) 把底槽支到机台沟的四角上。
- 2) 用螺钉②把前侧的A 2个头部橡胶支座①钉到机台的伸出部, 再用螺钉②把铰链侧B 的2个头部胶垫座③钉好固定, 然后把底槽④放上去。
- 3) 把铰链①放到机台的孔上, 对准台板橡胶支座②, 把头部放到四角的机头胶垫③上。

(1) Installing the under cover

- 1) The oil pan should rest on the four corners of the machine table groove.
- 2) Fix two rubber seats ① on side A (operator's side) using nails ② as illustrated above. Fix two cushion seats ③ on side B (hinged side) using a rubber-based adhesive. Then place oil pan ④ on the fixed seats.
- 3) Fit hinge ① into the opening in the machine bed, and fit the machine head to table rubber hinge ② before placing the machine head on cushions ③ on the four corners.

3. 膝动提升高度的调整 / ADJUSTING THE HEIGHT OF THE KNEE LIFTER



注意
为了防止意外的启动造成的事故，请关掉电源后进行。

WARNING:

Turn OFF the power before starting the work so as to prevent accidents caused by abrupt start of the sewing machine.

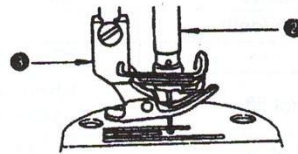
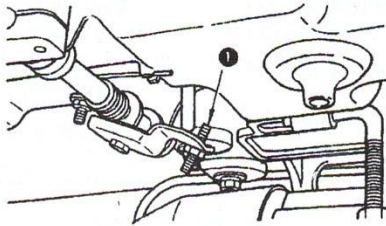

- 1) 膝动提升的压脚标准高度为10mm。
 - 2) 调节膝动提升调节螺丝 ① 可以把压脚高度最大调整到13mm。(A型时最大为9mm。)
 - 3) 压脚提升到10 mm 以上时，请注意针杆 ② 的前端下降到最底下时，不能碰到压脚 ③。
- 1) The standard height of the presser foot lifted using the knee lifter is 10 mm.
 - 2) You can adjust the presser foot lift up to 13 mm using knee lifter adjust screw ①. (Max. 9 mm for A type)
 - 3) When you have adjusted the presser foot lift to over 10 mm, be sure that the bottom end of needle bar ② in its lowest position does not hit presser foot ③.

4. 线架装置的安装 / INSTALLING THE THREAD STAND

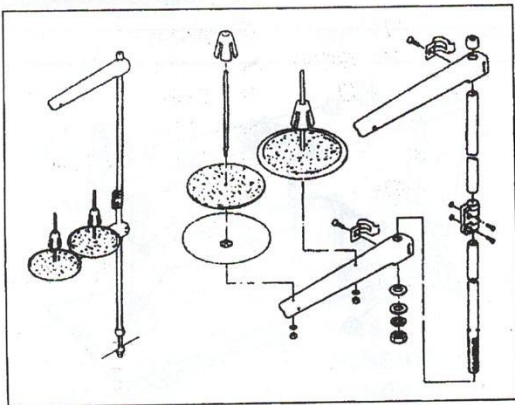

5. 加润滑脂 / LIPIN



注意

为了防止意外的起动造成的事故，请关掉电源后进行。

WARNING:

Turn OFF the power before starting the work so as to prevent accidents caused by abrupt start of the sewing machine.

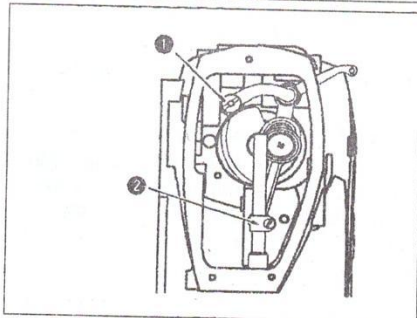

- 1) 请先卸下挑线连杆销①上的小螺钉后，将润滑脂注满挑线连杆销①的小孔内。
 - 2) 请先拆下针杆连接柱组件后卸下针杆连接柱②上的小螺钉，将润滑脂注满针杆连接柱②的小孔内。
- 1) Full pore of the thread take-up crank shaft① with lipin before disassembly small screw of the thread take-up crank shaft①.
 - 2) Disassembly small screw before Disassembly the needle rod holder ASM, then full pore of the needle bar connection ASM② with lipin.

6. 加油 / LUBRICATION



注意

为了防止意外的起动造成的事故，请关掉电源后进行。

WARNING:

Turn OFF the power before starting the work so as to prevent accidents caused by abrupt start of the sewing machine.

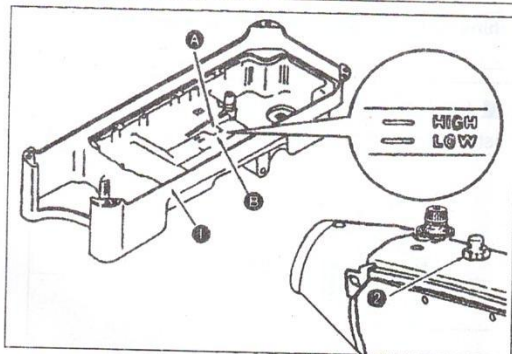

运转缝纫机前

- 1) 请把机油倒进油槽①里，一直加到 HIGH 标记 A 的位置。
- 2) 油槽的油面降到 LOW 标记 B 以下时，请再次补充机油。
- 3) 加油后运转缝纫机，如果润滑正常时，可以通过油窗②看到油的流动。
- 4) 油流动量的多少，与油量的多少无关。



注意 新缝纫机或较长时间没有使用的缝纫机在使用之前，应进行 10 分钟 3,000~3,500 rpm 的磨合运转。

Information on lubrication

- 1) Fill oil pan ① with Machine Oil up to HIGH mark A.
- 2) When the oil level lowers below LOW mark B, refill the oil pan with the specified oil.
- 3) When you operate the machine after lubrication, you will see splashing oil through oil sight window ② if the lubrication is adequate.
- 4) Note that the amount of the splashing oil is unrelated to the amount of the lubricating oil.



When you first operate your machine after setup or after an extended period of disuse, run your machine at 3,000 to 3,500 rpm. for about 10 minutes for the purpose of break-in.

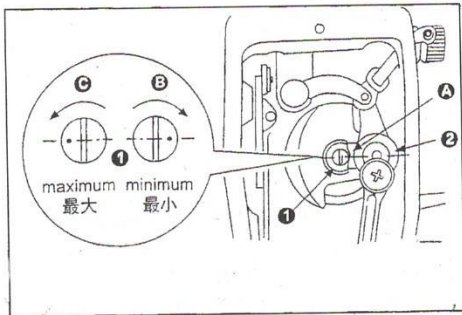

面部油量的调整

- 1) 调整挑线杆和针杆曲轴部 ② 的油量时，转动雨量调整销 ① 进行调整。
- 2) 调整销刻点 A 从图的位置向 B 方向转动，转动到接近针杆曲板 ② 时，油量最小。
- 3) 从图上所示的位置向 C 方向转动，当转到与针杆曲柄的正对的位置时，油量最大。

Adjusting the amount of oil supplied to the face plate parts

- 1) Adjust the amount of oil supplied to the thread take-up and needle bar crank ② by turning adjust pin ①.
- 2) The minimum amount of oil is reached when marker dot A is brought close to needle bar crank ② by turning the adjust pin in direction B.
- 3) The maximum amount of oil is reached when marker dot A is brought to the position just opposite from the needle bar crank by turning the adjust pin in direction C.

7. 关于旋梭部油量 (迹) 调整方法 /

ADJUSTING THE AMOUNT OF OIL (OIL SPLASHES) IN THE HOOK

注意
旋梭是以高速运转。为了防止人身事故，调整油量时，请加以充分的注意。

WARNING:
Be extremely careful about the operation of the machine since the amount of oil has to be checked by turning the hook at a high speed.

① 油量 (迹) 确认专用纸
Amount of oil (oil splashes) confirmation paper

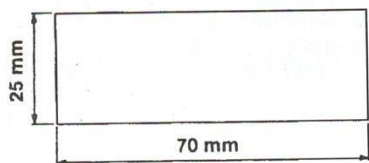

② 油量 (迹) 确认位置
Position to confirm the amount of oil (oil splashes)

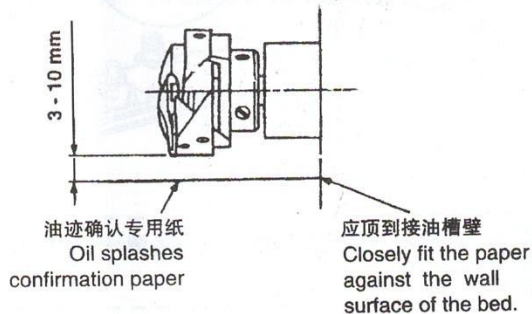

* 进行下列2)的作业时，请卸下滑板，同时要充分注意手指不要碰到旋梭。

- 1) 冷机头时，请进行3分钟左右的空运转。(适当的断续运转)
- 2) 油量 (迹) 确认专用纸在缝纫机转动后的状态下插进去。
- 3) 请确认油量的油面高度应在HIGH和LOW的范围之内。
- 4) 确认油量 (迹) 所需要的时间为5秒钟。(应看着表)

* When carrying out the procedure described below in 2, remove the slide plate and take extreme caution not to allow your fingers to come in contact with the hook.

- 1) If the machine has not been sufficiently warmed up for operation, make the machine run idle for approximately three minutes. (Moderate intermittent operation)
- 2) Place the amount of oil (oil splashes) confirmation paper under the hook while the sewing machine is in operation.
- 3) Confirm the height of the oil surface in the oil reservoir is within the range between "HIGH" and "LOW".
- 4) Confirmation of the amount of oil should be completed in five seconds. (Check the period of time with a watch.)

• 油量 (油迹) 适合标准 / Sample showing the appropriate amount of oil

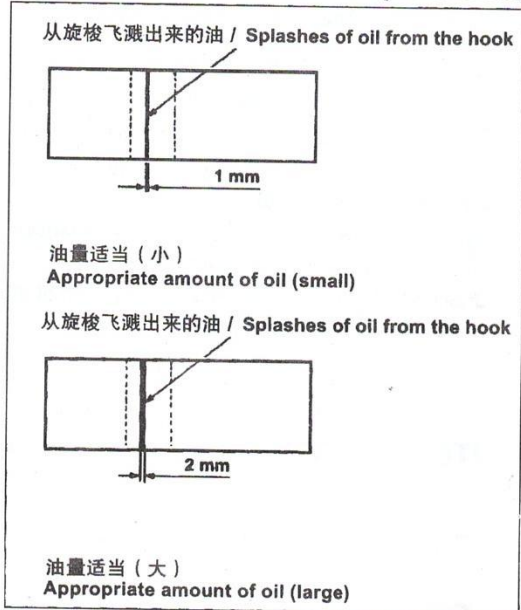

- 1) 左图标样根据缝制供需需要微调增减, 但注意不要过大增加或减少。
(油量过少时, 会烧坏旋梭 (发热)。油量过多时, 会脏污缝制品。)
- 2) 油量 (油迹) 应确认3次 (3张) 均无变化。

- 1) The amount of oil shown in the samples on the left should be finely adjusted in accordance with sewing processes. Be careful not to excessively increase/decrease the amount of oil in the hook.
(If the amount of oil is too small, the hook will be seized (the hook will be hot). If the amount of oil is too much, the sewing product may be stained with oil.)
- 2) Adjust the amount of oil in the hook so that the oil amount (oil splashes) should not change while checking the oil amount three times (on the three sheets of paper)

• 旋梭油量 (迹) 调整 / Adjusting the amount of oil

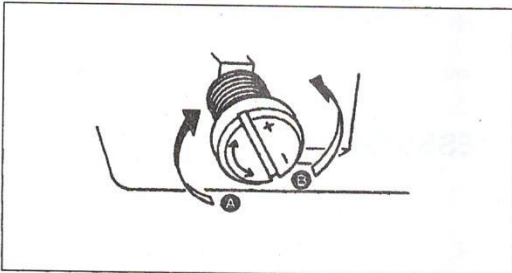

- 1) 把下轴前端金属部件上的油量调节螺丝向“+”的方向 (A方向) 转动, 油量 (迹) 变多, 向“-”的方向 (B方向) 转动, 油量 (迹) 变少。
- 2) 油量调节螺丝调整后的油迹, 应空运转 30 秒钟左右进行油量 (迹) 的确认。

- 1) Turning the oil amount adjustment screw attached on the hook driving shaft front bushing in the "+" direction (in direction A) will increase the amount of oil (oil spots) in the hook, or in the "-" direction (in direction B) will decrease it.
- 2) After the amount of oil in the hook has been properly adjusted with the oil amount adjustment screw, make the sewing machine run idle for approximately 30 seconds to check the amount of oil in the hook.

8. 机针的安装 / ATTACHING THE NEEDLE



注意

为了防止意外的起动造成的事故, 请关掉电源后进行。

WARNING:

Turn OFF the power before starting the work so as to prevent accidents caused by abrupt start of the sewing machine.

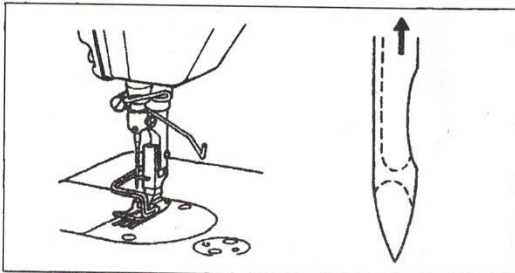

9. 梭心的安装方法 / SETTING THE BOBBIN INTO THE BOBBIN CASE

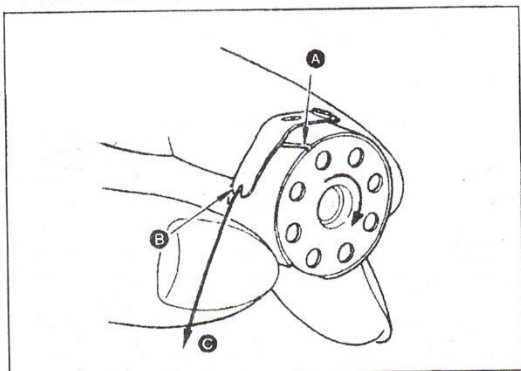

- 1) 把线穿过梭壳的穿线口A，然后把线往B方向拉，从线张力弹簧下面的穿线口B拉出来。
 - 2) 拉底线C，确认梭心是否按箭头方向转动。
- 1) Pass the thread through thread slit A, and pull the thread in direction B.
By so doing, the thread will pass under the tension spring and come out from notch B.
- 2) Check that the bobbin rotates in the direction of the arrow when thread C is pulled.

10. 线迹长度的调节 / ADJUSTING THE STITCH LENGTH

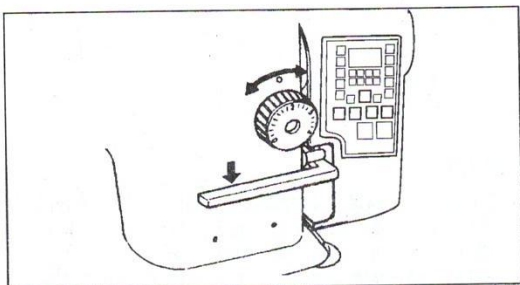

11. 压脚压力的调节 / PRESSER FOOT PRESSURE

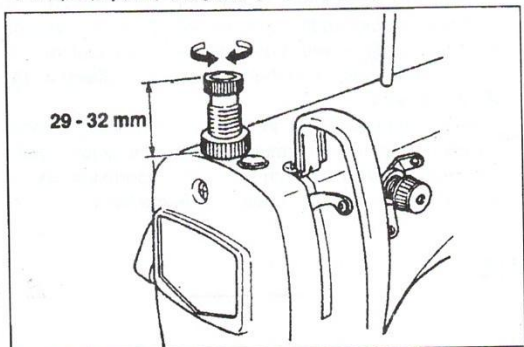

12. 关于压脚提升 / HAND LIFTER

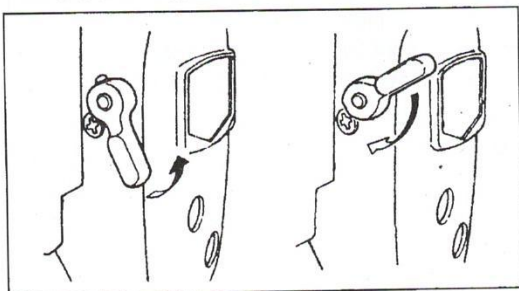

13. 压脚杆高度的调整 / ADJUSTING THE HEIGHT OF THE PRESSER BAR



注意

为了防止意外的起动作成的事故，请关掉电源后进行。

WARNING:

Turn OFF the power before starting the work so as to prevent accidents caused by abrupt start of the sewing machine.

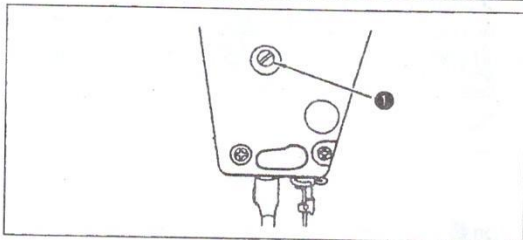

1) 变更压脚杆的高度或压脚的角度时，请拧松压脚杆套管固定螺丝①进行调整。

2) 调整后，拧紧固定螺丝①。

1) Loosen setscrew ①, and adjust the presser bar height or the angle of the presser foot.

2) After adjustment, securely tighten the setscrew ①.

14. 上线的穿线方法 / THREADING THE MACHINE HEAD



注意

为了防止意外的起动作成的事故，请关掉电源后进行。

WARNING:

Turn OFF the power before starting the work so as to prevent accidents caused by abrupt start of the sewing machine.

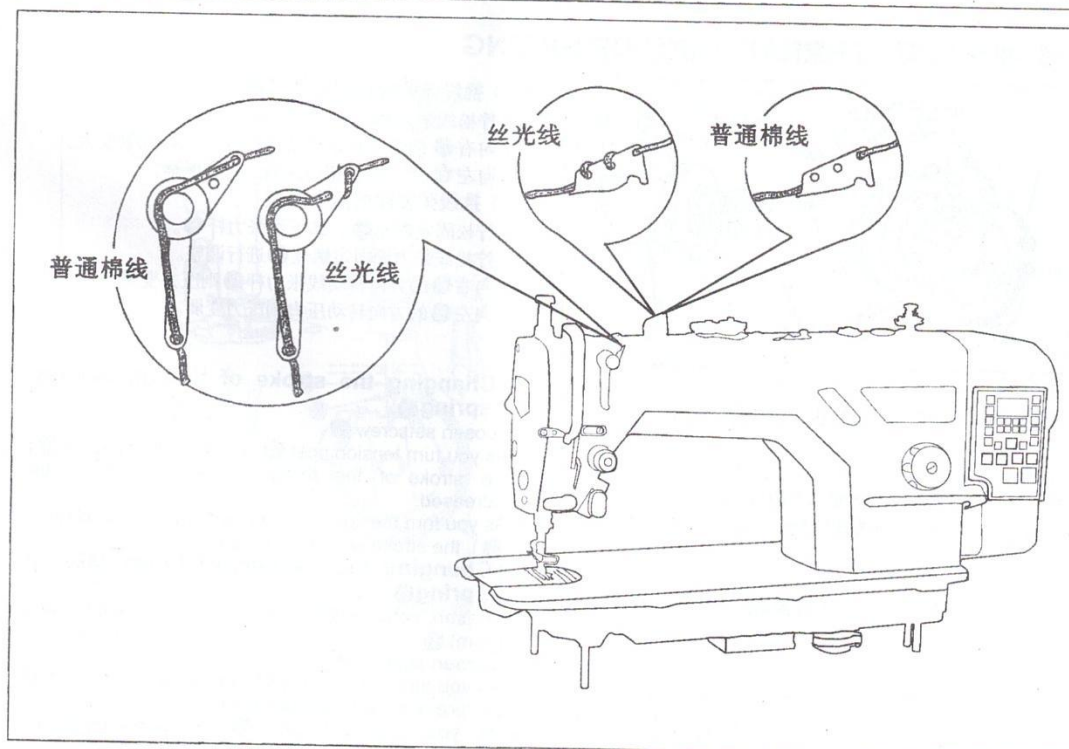

15. 线张力器 / THREAD TENSION

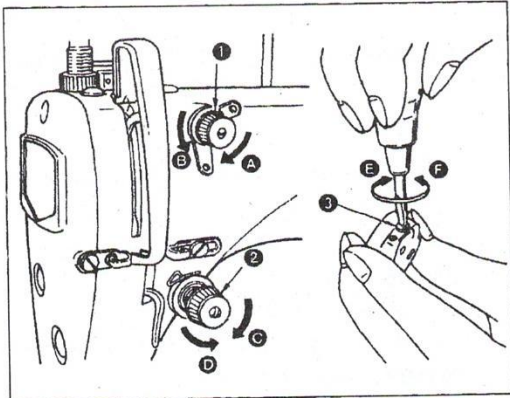

(1) 上线张力的调整

- 1) 向右 **A** 的方向转动第一线张力螺母 **1**，切线后残留在机针上的线长度变短。
- 2) 向左 **B** 的方向转动，则长度变长。
- 3) 向右 **C** 的方向转动第二线张力螺母 **2**，上线张力变强。
- 4) 向左 **D** 的方向转动，则上线张力变弱。

(2) 底线张力的调整

- 1) 向右 **E** 的方向转动线张力螺丝 **3**，底线张力变强。
- 2) 向左 **F** 的方向转动线张力螺丝，则底线张力变弱。

(1) Adjusting the needle thread tension

- 1) As you turn thread tension No.1 nut **1** clockwise (in direction **A**), the thread remaining on the needle after thread trimming will be shorter.
- 2) As you turn nut **1** counterclockwise (in direction **B**), the thread length will be longer.
- 3) As you turn thread tension No.2 nut **2** clockwise (in direction **C**), the needle thread tension will be increased.
- 4) As you turn nut **2** counterclockwise (in direction **D**), the needle thread tension will be decreased.

(2) Adjusting the bobbin thread tension

- 1) As you turn tension adjust screw **3** clockwise (in direction **E**), the bobbin thread tension will be increased.
- 2) As you turn screw **3** counterclockwise (in direction **F**), the bobbin thread tension will be decreased.

16. 挑线弹簧 / THREAD TAKE-UP SPRING

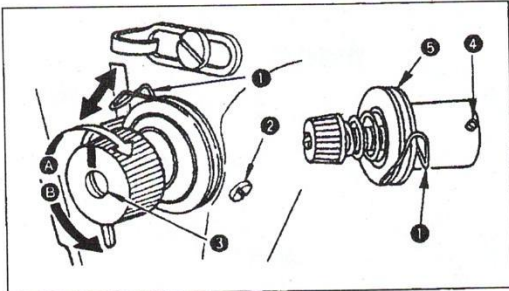

(1) 挑线弹簧 **1** 的行程量调整

- 1) 拧松线张力台的固定螺丝 **2**。
- 2) 向右 **A** 的方向转动线张力杆 **3**，则行程量变大。
- 3) 向左 **B** 为了防止布的跑偏，需要提早。

(2) 挑线弹簧 **1** 的压力调整

- 1) 拧松固定螺丝 **2**，卸下线张力杆 **5**。
- 2) 拧松线张力杆固定螺丝 **4** 进行调整。
- 3) 向右 **A** 的方向转动线张力杆 **3** 则压力变强。
- 4) 向左 **B** 的方向转动压力则压力变弱。

(1) Changing the stroke of thread take-up spring **1**

- 1) Loosen setscrew **2**.
- 2) As you turn tension post **3** clockwise (in direction **A**), the stroke of the thread take-up spring will be increased.
- 3) As you turn the knob counterclockwise (in direction **B**), the stroke will be decreased.

(2) Changing the pressure of thread take-up spring **1**

- 1) Loosen setscrew **2**, and remove thread tension (asm) **5**.
- 2) Loosen setscrew **4**.
- 3) As you turn tension post **3** clockwise (in direction **A**), the pressure will be increased.
- 4) As you turn the post **3** counterclockwise (in direction **B**), the pressure will be decreased.

17. 挑线杆挑线量的调整 / ADJUSTING THE THREAD TAKE-UP STROKE



注意

为了防止意外的启动造成的事故，请关掉电源后进行。

WARNING:

Turn OFF the power before starting the work so as to prevent accidents caused by abrupt start of the sewing machine.

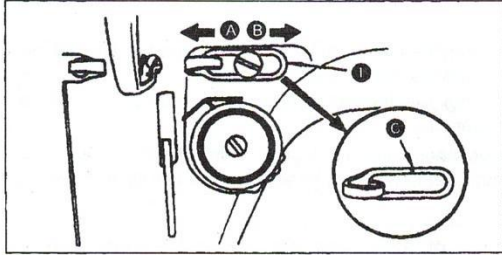

- 1) 缝制厚料时，向左(A)的方向移动线导向器①，则挑线量变多。
- 2) 缝制薄料时，向右(B)的方向移动线导向器①，则挑线量变少。
- 3) 线导向器①在刻线(C)对准螺丝的中心时是标准位置。

- 1) When sewing heavy-weight materials, move thread guide ① to the left (in direction A) to increase the length of thread pulled out by the thread take-up.
- 2) When sewing light-weight materials, move thread guide ① to the right (in direction B) to decrease the length of thread pulled out by the thread take-up.
- 3) Normally, thread guide ① is positioned in a way that marker line C is aligned with the center of the screw.

18. 机针与旋梭的关系 / NEEDLE-TO-HOOK RELATIONSHIP



注意

为了防止突然启动造成人身事故，请关掉电源，确认马达确实停止转动后再进行。

WARNING:

To avoid possible personal injury due to abrupt start of the machine, turn off the power to the machine and check to be sure that the motor has totally stopped rotating in prior.

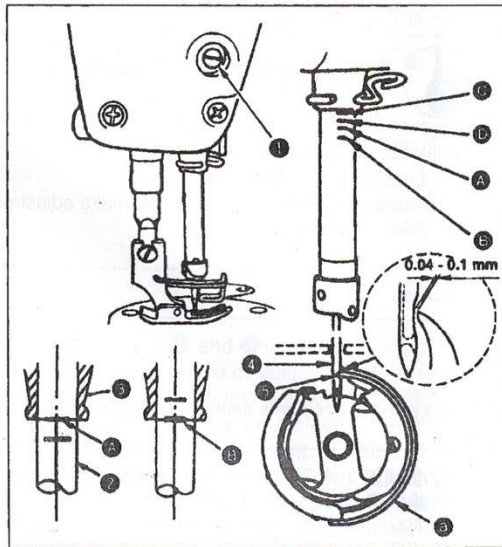

(1) 请按如下方法调整机针和旋梭。

- 1) 转动飞轮，让针杆降到最下点，然后拧松针杆套管固定螺丝①。
- (决定针杆高度)
- 2) [DB针时]
把针杆②的刻线A对准针杆下套筒③的下端，然后拧紧针杆套管固定螺丝①。
- [DA针时]
把针杆②的刻线C对准针杆下套筒③的下端，然后拧紧针杆套管固定螺丝①。
- (决定旋梭④的安装位置)
- 3) [DB针时]
拧松3根旋梭固定螺丝，转动飞轮在针杆②上升的方向，把刻线B对准针杆下套筒③的下端。
- [DA针时]
拧松3根旋梭固定螺丝，转动飞轮在针杆②上升的方向，把刻线D对准针杆下套筒③的下端。
- 4) 在此状态下，让旋梭尖⑤对准机针④的中心，把机针与旋梭的间隙调整为0.04~0.1mm(大致)，然后拧紧螺丝。



间隙过小的话，会损伤旋梭尖。间隙过大的话，会跳针。

(1) Adjust the timing between the needle and the hook as follows:

- 1) Turn the handwheel to bring the needle bar down to the lowest point of its stroke, and loosen setscrew ①
(Adjusting the needle bar height)
- 2) **(For a DB needle)** Align marker line ④ on needle bar ② with the bottom end of needle bar lower bushing ③, then tighten setscrew ①.
(For a DA needle) Align marker line ⑤ on needle bar ② with the bottom end of needle bar lower bushing ③, then tighten setscrew ①.
(Adjusting position of the hook a)
- 3) **(For a DB needle)** Loosen the three hook setscrews, turn the handwheel and align marker line ⑥ on ascending needle bar with the bottom end of needle bar lower bushing ③.
(For a DA needle) Loosen the three hook setscrews, turn the handwheel and align marker line ⑦ on ascending needle bar with the bottom end of needle bar lower bushing ③.
- 4) After making the adjustments mentioned in the above steps, align hook blade point ⑧ with the center of needle ④. Provide a clearance of 0.04 mm to 0.1mm (reference value) between the needle and the hook, then securely tighten setscrews in the hook.



If the clearance between the blade point of hook and the needle is smaller than the specified value, the blade point of hook will be damaged. If the clearance is larger, stitch skipping will result.

19. 送布牙的高度 / HEIGHT OF THE FEED DOG



注意
为了防止意外的起动力造成的事故，请关掉电源后进行。

WARNING:

Turn OFF the power before starting the work so as to prevent accidents caused by abrupt start of the sewing machine.

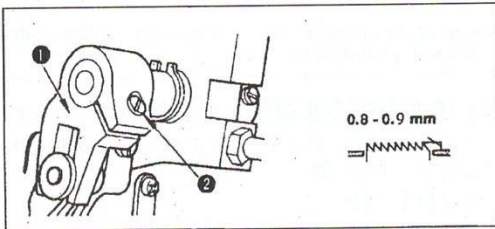

调节送布牙的高度时

- ① 拧松上下送布双叉 ① 的紧固螺丝 ②。
- ② 上下移动送布台进行调节。
- ③ 拧紧固定螺丝 ②。



注意 紧固压力过弱的话，抬牙叉部的动作则变得不灵活了。

To adjust the height of the feed dog:

- ① Loosen screw ② of crank ①
- ② Move the feed bar up or down to make adjustment.
- ③ Securely tighten screw ②



If the clamping pressure is insufficient, the motion of the forked portion becomes heavy.

20. 送布牙的倾斜 / TILT OF THE FEED DOG



注意
为了防止意外的起动力造成的事故，请关掉电源后进行。

WARNING:

Turn OFF the power before starting the work so as to prevent accidents caused by abrupt start of the sewing machine.

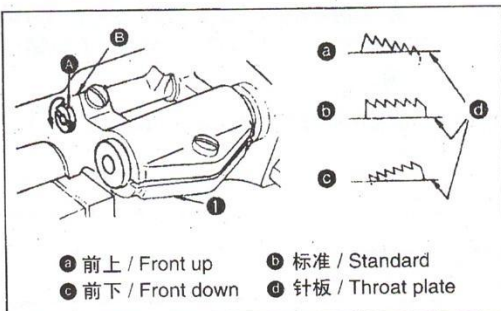

- 1) 标准倾斜（水平）度是送布台轴的刻点A和送布台曲柄①的B部一致时的位置。
(的标准倾斜是对B部呈90度水平送布面向轴侧的位置。)
- 2) 为了防止缝制皱摺，向前抬起送布牙时，请拧松固定螺丝，把螺丝刀插入送布台轴，然后沿箭头方向转90度。
- 3) 为了减少布的偏斜，向前下降送布牙时，请沿与箭头方向相反方向转90度。

- ① 前上 / Front up ② 标准 / Standard
③ 前下 / Front down ④ 针板 / Throat plate



注意了送布牙之后，送布齿的高度会有变化，请再次确认。

- 1) The standard tilt (horizontal) of the feed dog is obtained when marker dot **A** on the feed bar shaft is aligned with marker dot **B** on feed rocker **1**. (the marker dot **B** inclines forward the feed rocker shaft by 90°, as standard).
- 2) To tilt the feed dog with its front up in order to prevent puckering, loosen the setscrew, and turn the feed bar shaft 90° in the direction of the arrow, using a screwdriver.
- 3) To tilt the feed dog with its front down in order to prevent uneven material feed, turn the feed bar shaft 90° in the opposite direction from the arrow. (The standard tilt for.)



Whenever the feed dog tilt is adjusted, the feed dog height will be changed. So, it is necessary to check the height after tilt adjustment.

21. 送布相位的调节 / ADJUSTING THE FEED TIMING



注意

为了防止突然启动造成人身事故，请关掉电源，确认马达确实停止转动后再进行。

WARNING:

To avoid possible personal injury due to abrupt start of the machine, turn off the power to the machine and check to be sure that the motor has totally stopped rotating in prior.

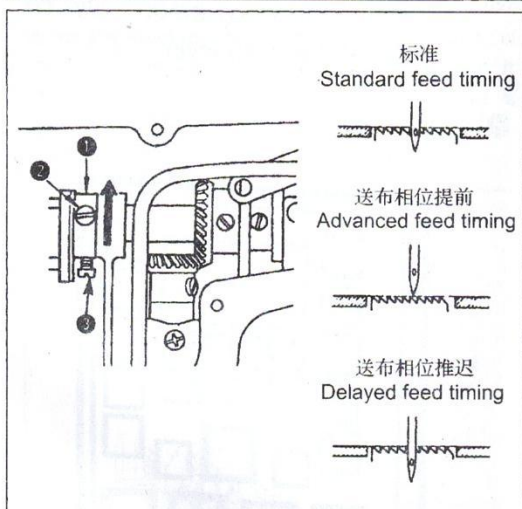

- 1) 拧松送布偏心凸轮**1**的固定螺丝**2**、**3**，朝箭头方向或反箭头方向移动送布偏心凸轮，然后拧紧固定螺丝。
- 2) 标准调节位置是送布牙从针板下落时，送布牙上面与针孔上端对准针板上面的位置。
- 3) 提早送布相位以防止布偏斜时，请向箭头方向移动送布偏心凸轮。
- 4) 为了良好的紧线而推迟相位时，请逆箭头方向移动偏心凸轮。



移动距离过大会发生断针故障。

- 1) Loosen screws **2** and **3** in feed eccentric cam **1**, move the feed eccentric cam in the direction of the arrow or opposite direction of the arrow, and firmly tighten the screws.
- 2) For the standard adjustment, adjust so that the top surface of feed dog and the top end of needle eyelet are flush with the top surface of throat plate when the feed dog descends below the throat plate.
- 3) To advance the feed timing in order to prevent uneven material feed, move the feed eccentric cam in the direction of the arrow.
- 4) To delay the feed timing in order to increase stitch tightness, move the feed eccentric cam in the opposite, direction from the arrow.



Be careful not to move the feed eccentric cam too far, or else needle breakage may result.

22. 机针停止位置的调整 / ADJUSTING THE NEEDLE STOP POSITION



注意

为了防止意外的启动造成的事故，请关掉电源后进行。

WARNING:

Turn OFF the power before starting the work so as to prevent accidents caused by abrupt start of the sewing machine.

总则：机头标定挑线杆位置

- 1). 打开开关，进入工作模式；
- 2). 按住 "F" 键2秒，进入标机头界面；把挑线杆转到离最高点1.5~2mm位置；
- 3). 按住 "S" 键保存机头位置后系统自动返回到工作界面，蜂鸣器响一下；机头标定完成。

注：如果误进入标机头界面，按 "F" 键返回即可。

General principle:

the head is calibrated to thread take-up lever

- 1). Turn on power button, enter work mode;
- 2). Press the "F" key for 2 seconds, the standard nose interface, the thread take-up to the position which is far from the highest position 1.5~2mm;
- 3). Press "S" key to save the head position, the system automatically return to the working interface, buzzer look; nose calibration is complete.

Note: If you mistakenly entered the head of the table interface, press the "F" key to return to.

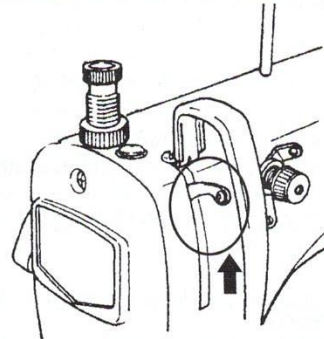

挑线杆位置示意图
Schematic diagram of
thread take-up lever

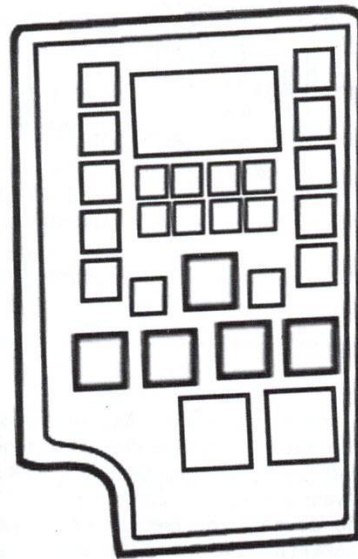

操作盘
Operation panel

23. 固定刀 / COUNTER KNIFE

(1) 割线刀凸轮位置的调节

转动缝纫机的皮带轮，当针棒从最低位置上升5毫米时，用手压割线螺旋管使滚轮轴接触割线凸轮 ① 的内凹部，然后用定位螺丝 ② 临时固紧，然后把割线螺旋管 ③ 返回到原来的位置(离开位置)，同时放松定位螺丝 ② 调节割线凸轮 ①，使凸轮端面 and 滚轮轴端面之间的间隙为0.5毫米。(以40公斤一厘米的扭矩拧紧定位螺丝 ②)。

(2) 移动刀片、固定刀片位置的调整

当割线凸轮控制杆 ④ 的头部超过割线凸轮时，固定刀片 ⑤ 的前端和转移刀片 ⑥ 的刀刃部应当啮合0.2-0.5毫米。当不啮合时，在滚轮轴超过割线凸轮 ① 的情况下移动割线控制杆 ⑦，使固定刀片 ⑤ 的前端和移动刀片 ⑥ 刀刃部相啮合，然后拧紧螺丝 ⑧。

(1) Adjusting the position of thread cutting cam

Turn the wheel of sewing machine. When the needle bar rise by 5mm from the lowest position, press the thread cutting serpentine pipe to make the roller shaft contact the rabbet of the thread cutting cam ① and the fix with the positioning screw ② temporarily, after that adjust the thread cutting serpentine pipe ③ to the original place. At the same time, loose the positioning screw ② to adjust the thread cutting wheel ②, keeping the clearance between the head face of the cam and the roller shaft to 0.5mm (Fix the positioning screw ② at a torque moment of 40kg/cm).

(2) Adjusting the place of movingknife and fixed knife

When the head of thread cutting cam controlling lever ⑦ surpasses the thread cutting cam, the front part of the fixed knife ⑤ should mesh with the edge of the moving knife ⑥ in 0.2-0.5mm. When failed to mesh, move the moving thread cutting controlling lever ⑦ under the condition that roller shaft surpasses the thread cutting cam, making the front of the fixed knife ⑤ to mesh with the edge of the moving knife and then fixed the screw ⑧.

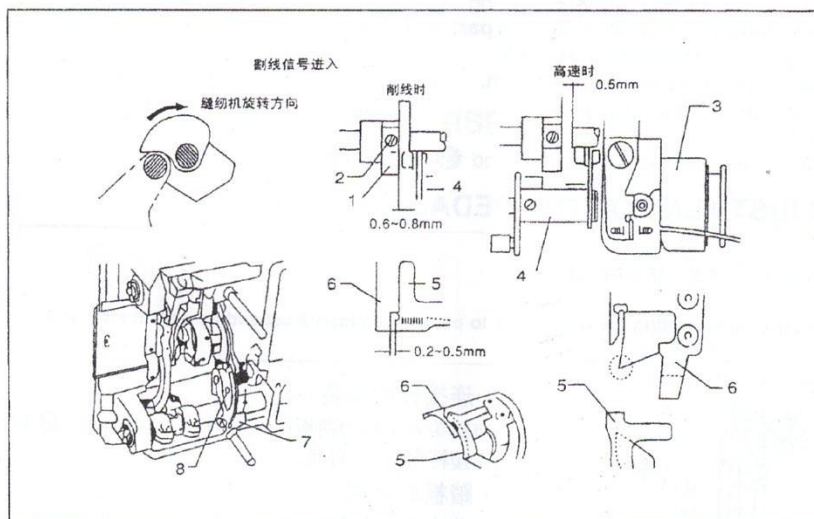

24. 踏板压力和行程 / PEDAL PRESSURE AND PEDAL STROKE



注意

为了防止意外的启动造成的事故，请关掉电源后进行。

WARNING:

Turn OFF the power before starting the work so as to prevent accidents caused by abrupt start of the sewing machine.

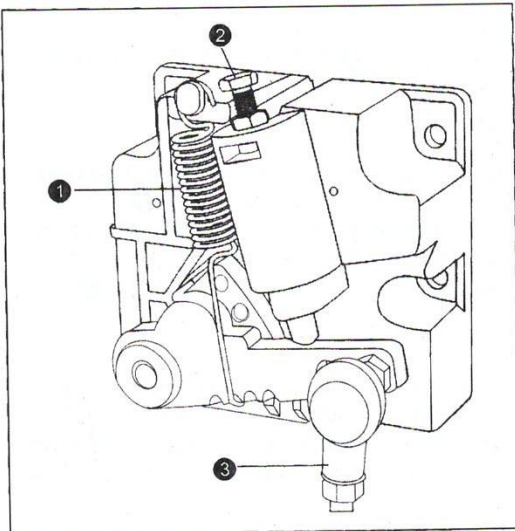

(1) 踏板踩踏压力的调整

- 1) 换成前踩踏弹簧 ① 可以调整。
- 2) 把弹簧挂到左侧之后，压力变轻。
- 3) 挂到右侧之后变重。

(2) 踏板回踩力的调整

- 1) 用踏板回踩压力调节弹簧 ② 可以调整。
- 2) 拧进调节螺丝则压力变大。
- 3) 拧松调节螺丝则压力变小。

(3) 踏板踩踏行程的调整

- 1) 把连杆杆 ③ 插到右侧的孔里之后行程变大。

(1) Adjusting the pressure required to depress the front part of pedal

- 1) This pressure can be changed by changing the mounting position of pedaling pressure adjust spring ①.
- 2) The pressure decreases when you hook the spring on the left side.
- 3) The pressure increases when you hook the spring on the right side.

(2) Adjusting the pressure required to depress the back part of pedal

- 1) This pressure can be adjusted using regulator screw ②.
- 2) The pressure increases as you turn the regulator screw in.
- 2) The pressure decreases as you turn the screw out.

(3) Adjusting the pedal stroke

- 1) The pedal stroke increases when you insert connecting rod ③ into the right hole.

25. 踏板的调整 / ADJUSTMENT OF THE PEDAL



注意

为了防止意外的启动造成的事故，请关掉电源后进行。

WARNING:

Turn OFF the power before starting the work so as to prevent accidents caused by abrupt start of the sewing machine.

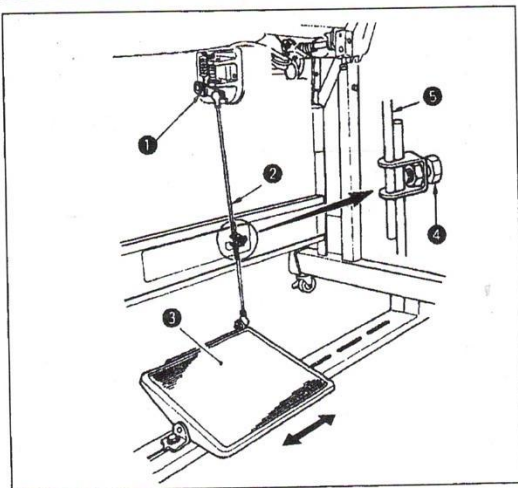

(1) 连接杆的安装

- 1) 向箭头方向移动踏板调节板 ③，让踏板拨杆 ① 和连接杆 ② 呈一直线。

(2) 踏板的角度

- 1) 调节连接杆的长度就可以自由地改变踏板的倾斜度。
- 2) 拧松调节螺丝 ④，拉出插入连接杆 ⑤ 进行调整。

(1) Installing the connecting rod

- 1) Move pedal ③ to the right or left as illustrated by the arrow so that motor control lever ① and connecting rod ② are straightened.

(2) Adjusting the pedal angle

- 1) The pedal tilt can be freely adjusted by changing the length of the connecting rod.
- 2) Loosen adjust screw ④, and adjust the length of connecting rod ⑤.

26. 踏板操作 / PEDAL OPERATION

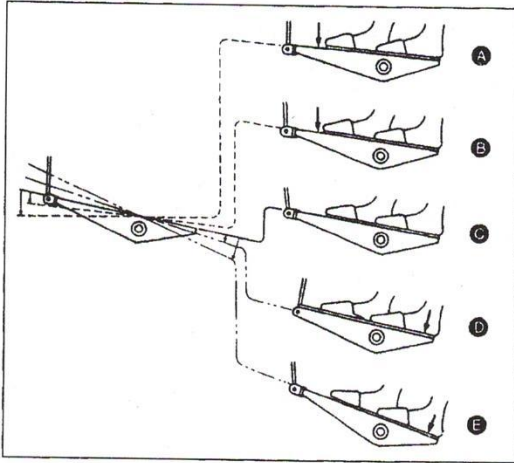

(1) 踏板按4个阶段进行操作。

- 1) 向前轻轻踩踏板为低速缝制[ⓑ]。
- 2) 再用力向前踩踏板则变为高速缝制[Ⓐ]。
(但是, 开关设定为自动倒缝时, 倒缝结束后进行高速缝制)
- 3) 把踏板返回到脚轻轻地放到踏板上的位置缝纫机停止[ⓒ]。(机针上停止或下停止位置)
- 4) 用力向后踩踏板则为切线动作[Ⓔ]。
* 使用自动压脚提升装置时, 在停止和切线之间增加1级开关。向后轻轻的踩踏板为压脚提升动作[Ⓓ], 再往后用力踩踏板为切线动作。

(1) The pedal is operated in the following four steps:

- 1) The machine runs at low sewing speed when you lightly depress the front part of the pedal. [ⓑ]
 - 2) The machine runs at high sewing speed when you further depress the front part of the pedal. [Ⓐ]
(If the automatic reverse feed stitching has been preset, the machine runs at high speed after it completes reverse feed stitching)
 - 3) The machine stops (with its needle up or down) when you reset the pedal to its original position. [ⓒ]
 - 4) The machine trims threads when you fully depress the back part of the pedal. [Ⓔ]
- * If your machine is provided with the Auto-lifter an addition step is given between the machine stop and thread trimming step. The presser foot goes up when you lightly depress the back part of the pedal [Ⓓ], and if you further depress the back part, the thread trimmer is actuated.

27. 触键手动倒缝 / LED 照明灯

ONE-TOUCH TYPE REVERSE FEED STITCHING MECHANISM

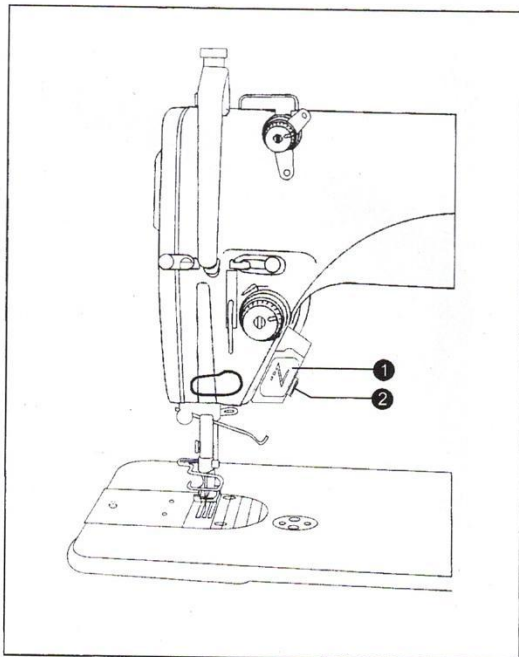

(1) 使用方法

- 1) 按开关按钮^①, 缝纫机立即变为倒送, 进行倒缝。
- 2) 按下按钮的时间, 可以进行倒缝。
- 3) 放开按钮, 则立即返回到正缝。



注意

为了防止意外的起动造成的事故, 请关掉电源后进行。

(1) How to operate

- 1) The moment button ^① is pressed, the machine performs reverse feed stitching.
- 2) The machine performs reverse feed stitching as long as the button is held pressed.
- 3) The machine resumes normal feed stitching the moment the button is released.



WARNING:

Turn OFF the power before starting the work so as to prevent accidents caused by abrupt start of the sewing machine.

(2) LED照明灯的使用方法

- 1) 向前推动开关 ②, LED灯亮。
- 2) 向后推动开关 ②, LED灯灭。

(2) How to operat the LED light

- 1) Push the button ②, LED light be bright.
- 2) Pull the button ②, LED light be power off.

零件手册

PARTS BOOK

选购零件部件时，请注明序号，件号。

**Please confirm the relative applications Ref. No,part No.
when buying the parts.**

1.机壳·外装部件

MACHINE FRAME&MISCELLANEOUS COVER COMPONENTS

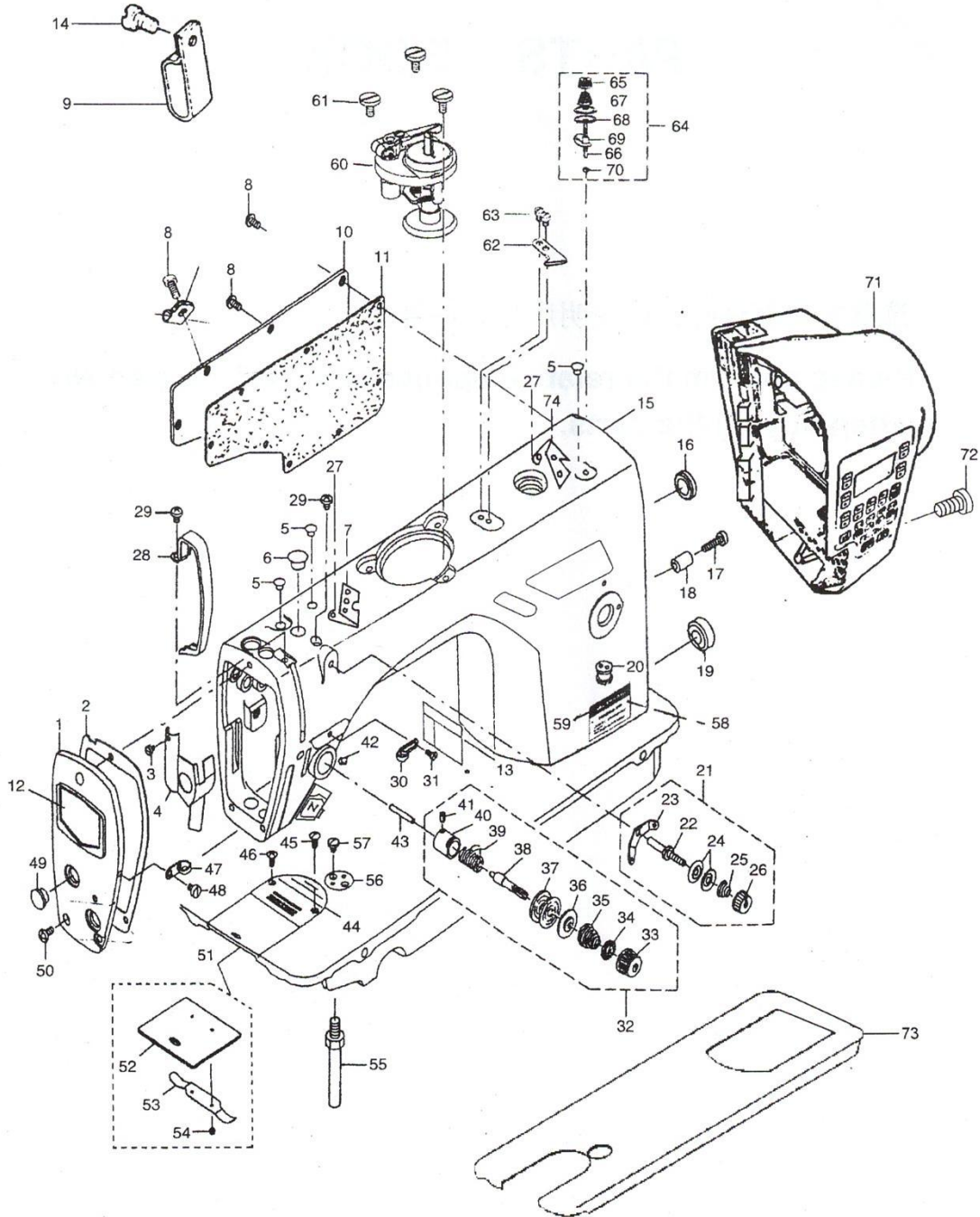

1.机壳·外装部件

序号 Ref. NO.	件号 Part NO.	名称	Description	数量 Qty	备注 Note
1	GR9890-01	面板	Face plate	1	
2	GR9890-02	面板垫	Face plate agsket	1	
3	GG544	防油板螺钉	Screw 1/8x44 L=4	1	
4	GR3403	面板防油板部件	Arm oil shifld asm.	1	
5	GR3344	挑线连杆销螺孔塞	Rubber plug	3	
6	GR1463	针杆曲柄螺孔塞	Rubber plug	1	
7	GR9890-42	三孔过线	Three holes thread guide plate	1	
8	GS053	后窗板螺钉	Screw 3/16x28 L=9	7	
9	GR1083-8	导线夹板	Cord holder	1	
10	GK9890-03	后窗板	Side plate	1	
11	GR9890-04	后窗板垫	Gasket	1	
12	GQ277	面板装饰片	Face plate	1	
13	GQ196	安全指示牌	Safety label	1	
14	GS053-8	后窗板螺钉	Screw 3/16x28 L=14	3	
15		机壳	Machine cover	1	
16	GR3345	送料调节器孔塞	Rubber plug	1	
17	GS046	倒缝限位套紧固螺钉	Screw 3/16x28 L=18	1	
18	GO061-8	倒缝限位套	Reverse feed lever stopper	1	
19	GR1464	下轴盲孔塞	Rubber plug	1	
20	GR1005-8	导线过线套	Magnet cord rubber	1	
21	GR9890-29	调线夹线器组件	Thread tension asm.	1	
22	GR7650	调线夹线螺钉	Thread tension post	1	
23	GR7673	调线过线板	Thread tension guide	1	
24	GR1015-8	小夹线板	Thread tension disk	2	
25	GW233-8	小夹线簧	Thread tension spring	1	
26	GS1750	小夹线螺母	Thread tension nut	1	
27	GS551	小夹线器组件螺钉	Screw 11/61 x 40 L=6	1	
28	GK240	挑线杆防护罩	Thread take-up lever cover	1	
29	GS551	挑线杆防护罩螺钉	Screw 3/16x28 L=6	3	
30	GR3354	右线钩	Arm thread guide Right	1	
31	GS0552	右线钩螺钉	Screw 11/64x40 L=6	1	
32		夹线器组件	Thread tension asm.	1	
33	GL0113	夹线螺母	Tension nut	1	
34	GR1490	夹线制动板	Rotating stopper	1	
35	GW251	夹线簧	Tension spring	1	
36	GR1489	夹线板	Thread tension disk presser	1	
37	GR1488	夹线板	Thread tension disk	2	
38	GS015	夹线螺钉	Tension post	1	
39	GW250	挑线簧	Take-up spring	1	
40	GR1487	挑线簧调节座	Tension post socket	1	
41	GS016	夹线螺钉紧固螺钉	Screw 9/64x40 L=5.5	1	
42	GS48	夹线器螺钉	Screw 15/64x28 L=7	1	
43	GX567	松线钉	Tension releasing	1	
44	GM202	针板	Throat plate	1	
45	GS044	针板螺钉	Screw 11/64x40 L=6	1	
46	GS044	针板螺钉	Screw 11/64x40 L=6	1	

1. 机壳 · 外装部件

MACHINE FRAME & MISCELLANEOUS COVER COMPONENTS

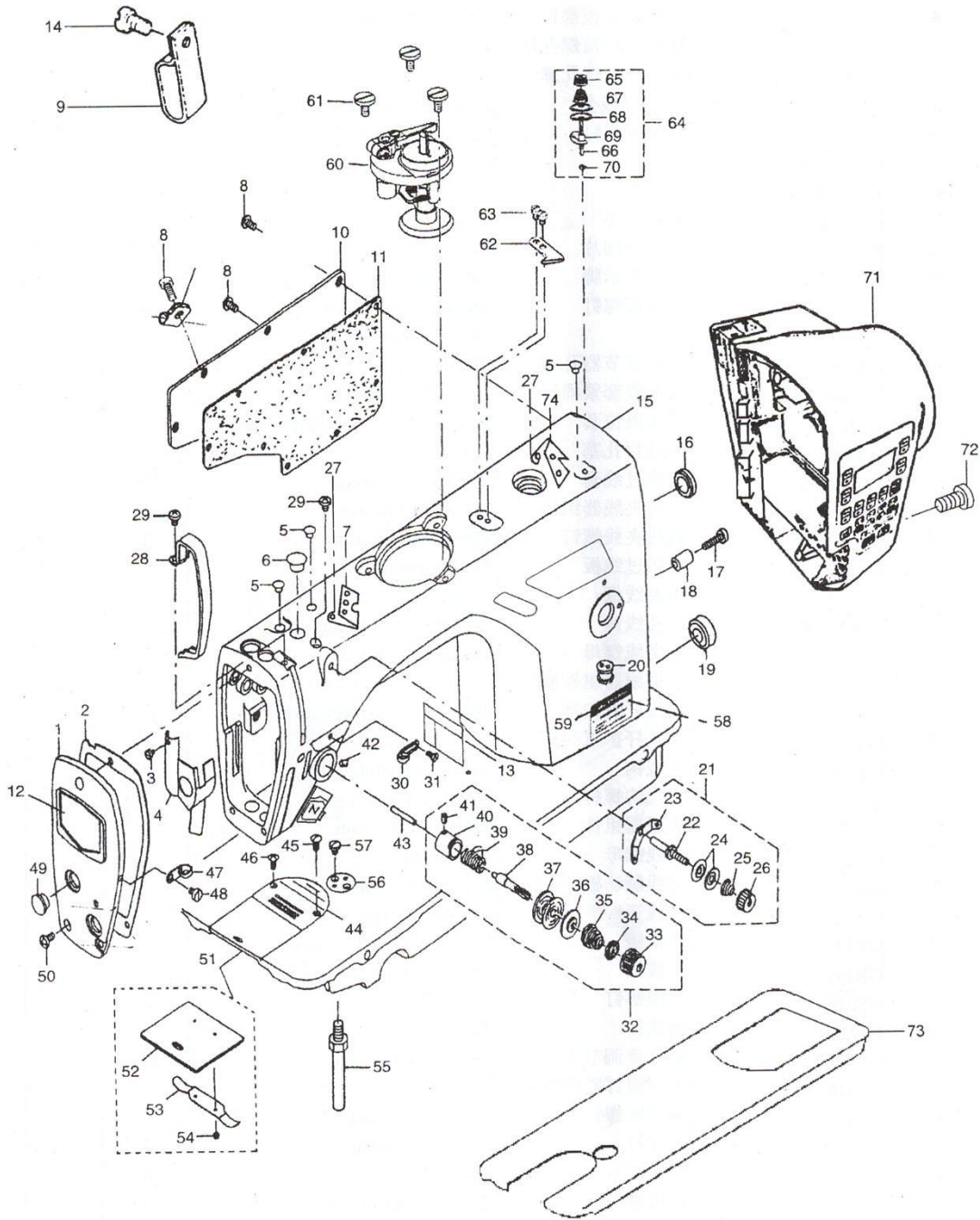

1.机壳·外装部件

序号 Ref. NO.	件号 Part NO.	名称	Description	数量 Qty	备注 Note
47	GR3355	左线钩	Arm thread guide Left	1	
48	GS0551	左线钩螺钉	Screw 11/64x40 L=6	1	
49	GR1458	面板调节螺孔塞	Ribber plug	2	
50	GS053	面板螺钉	Screw 3/16x28 L=9	3	
51	GM340/4	推板部件	Slide plate asm.	1	
52	GM204	推板	Slide plate	1	
53	GW434	推板簧	Bed slide spring	1	
54	GS045	推板簧螺钉	Screw 3/32x56 L=2.2	2	
55	GS0548	底板支柱	Bed screw stud	4	
56	GR724	夹边器	Ruler stopper	1	
57	GS373	夹边器螺钉	Screw 11/64x40 L=6	2	
58	GX565	型号牌铆钉	Pole	2	
59	GQ276-8	型号牌	Model plate	1	
60	GR9890-40	绕线器组件	Bobbin base	1	
61	GS9890-41	绕线器螺钉	Screw	3	
62	GR9890-26	割线刀	Knife	1	
63	GS226	绕线器割线刀螺钉	Knife screw	2	
64	GR9890-38	夹线器组件	Thread tension asm.	1	
65	GR9890-38-1	夹线螺母	Tension nut	1	
66	GR9890-38-2	夹线螺钉	Tension post	1	
67	GR9890-38-3	夹线弹簧	Tension spring	1	
68	GR9890-38-4	夹线板	Thread tension disk presser	2	
69	GR9890-38-5	过线板	Thread tension guide	1	
70	GR9890-38-6	夹线螺母(下)	Tension nut	1	
71	GR9890-46	电机罩壳	Motor cover	1	
72	GS1769	电机罩紧固螺钉	Screw 3/16 x 28 L=20	3	
73	GR9890-47	不锈钢工作台面	Stainless steel working table	1	
74	GR9890-35	过线导线器	Thread guide plate	1	

2. 上轴·挑线部件

MAIN SHAFT & THREAD-UP LEVER COMPONENTS

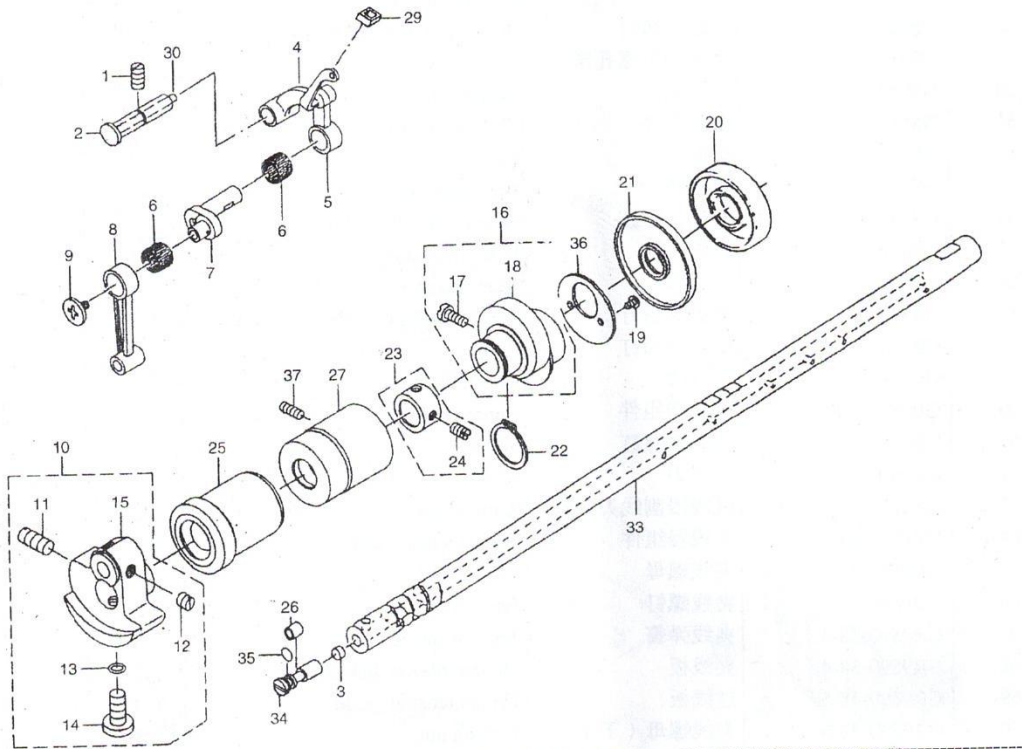

3. 一体式电控系统

IMPACT CONTROLLER SYSTEM

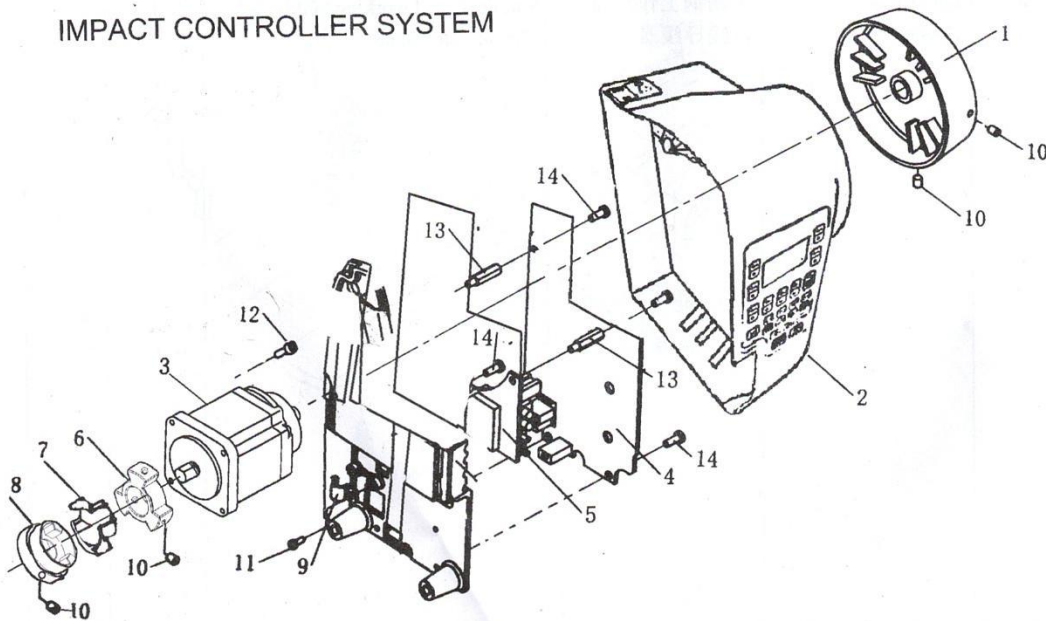

2. 上轴 · 挑线部件

序号 Ref. NO.	件号 Part NO.	名称	Description	数量 Qty	备注 Note
1	GS04	挑线连杆销螺钉	Screw 15/64x28 L=10.5	1	
2	GX566	挑线连杆销	Thread take-up crank shaft	1	
3	GR1470	曲柄油量限制毡	Roller felt	1	
4	GH564/4	挑线连杆	Thread take-up lever	1	
5	GH564/6	挑线连杆分组件	Thread take-up lever asm.	1	
6	GO270	挑线杆滚针轴承	Needle bearing	2	
7	GH402/2	挑线曲柄部件	Needle bar crank	1	
8	GH334	针杆连杆	Needle bar crank rod	1	
9	GS09	挑线曲柄左旋螺钉	Left screw 9/64x40 L=4.8	1	
10	GH561-8	针杆曲柄组件	Counter weight asm.	1	
11	GD0550	针杆曲柄紧固螺钉	Screw 9/32x28 L=16	1	
12	GD39	挑线曲柄定位螺钉	Screw 1/4x40 L=6	2	
13	GR1472	定位螺钉O型圈	Rubber ring	1	
14	GD06	针杆曲柄定位螺钉	Screw 9/32x28 L=15.5	1	
15	GH9890-65	针杆曲柄	Counter weight	1	
16		送料偏心轮组件	Feed drive eccentric cam asm.	1	
17	GD034	送料偏心轮螺钉	Screw 1/4x40 L=11	2	
18	GT198	送料偏心轮	Feed drive eccentric cam	1	
19	GD011	送料偏心轮盖板螺钉	Screw 9/64x40 L=6	2	
20	GR9890-11	轴承(6907Z)	Needle bearing	1	
21	GR9890-09	上轴油封	Oil seal	1	
22	GR1535	拾牙连杆轴挡圈	Snap ring	1	
23	GR1469	上轴挡圈组件	Thrust collar asm.	1	
24	GS39	上轴挡圈螺钉	Screw 1/4x40 L=6	2	
25	GO9890-06	上轴前轴套	Main shaft front bushing asm.	1	
26	GO296	曲柄油量调节销	Oil adjusting collar	1	
27	GO9890-07	上轴中轴套	Bushing, intermediate	1	
29	GR9890-22	橡皮套	Rubber	1	
30	GR3350	挑线连杆销毛毡	Thread take-up crank shaft felt	1	

3. 一体式电控系统

序号 Ref. NO.	件号 Part NO.	名称	Description	数量 Qty	备注 Note
1	GP9890-45	手轮	Hand wheel	1	
2		电机壳	Belt cover	1	
3	GR9890.36	电机	Motor asm	1	
4		PCB1		1	
5		PCB2		1	
6	GR9896.30	连轴器A	Connect block A	1	
7	GR9896.32	连轴器橡胶圈	Connect rubber	1	
8	GR9896.31	连轴器B	Connect block B	1	
9		电源压线板	Electricity line pressing board	1	
10		紧定螺钉	Holding screw	8	
11		十字组合螺钉	Cross recess head screw	2	
12		内六角螺钉	Socket head screw	3	
13		铜柱	Copper cylinder	2	
14		十字组合螺钉	Cross recess head screw	5	

4. 针杆 · 竖轴 · 下轴部件

NEEDLE BAR, UPRIGHT SHAFT & HOOK DRIVING SHAFT COMPONENTS

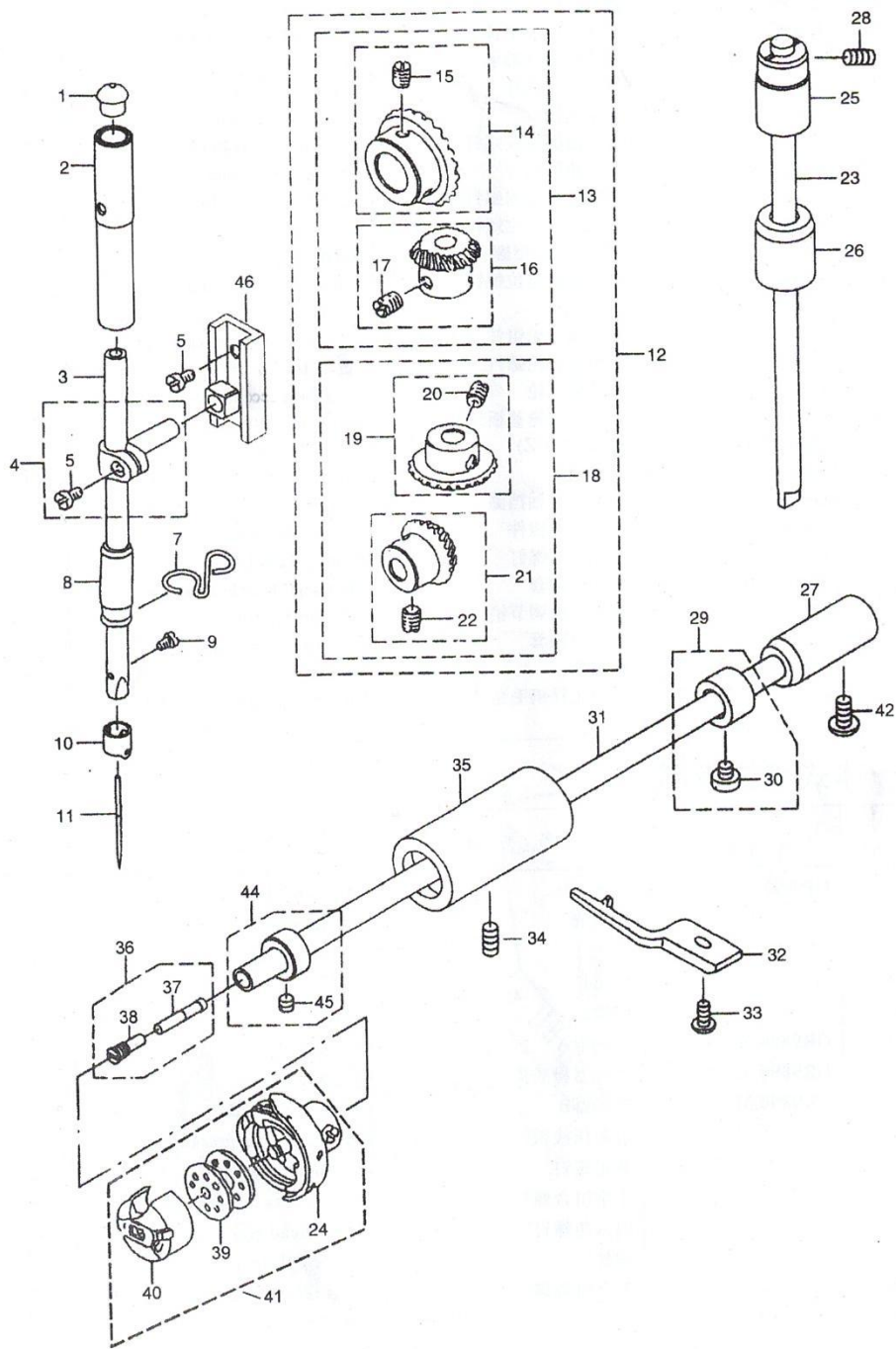

4.针杆·竖轴·下轴部件

序号 Ref. NO.	件号 Part NO.	名称	Description	数量 Qty	备注 Note
1	GR1479	针杆上孔塞	Cap	1	
2	GO9890-17	针杆上套	Needle bar bushing upper	1	
3	GZ9890-16	针杆	Needle bar	1	
4	GR1478	针杆连接柱组件	Needle rod holder asm.	1	
5	GS011	针杆连接柱螺钉	Screw 9/64x40 L=7.5	3	
6	GU168	针杆连接柱滑块	Slide block	1	
7	GR9890-18	针杆下套线钩	Needle bar thread guide	1	
8	GO272	针杆下套	Needle bar bushing, lower	1	
9	GS071	机针螺钉	Screw 1/8x44 L=4.8	1	
10	GR3352	针杆线钩	Needle bar thread guide	1	
11	GV15	机针	Needle DBX1 #14	1	
12		伞齿轮组件	Gear & pinion asm.	1	
13		上齿轮组件	Gear & pinion asm., upper	1	
14	GC168	上轴伞齿轮组件	Gear asm.	1	
15	GS033	伞齿轮螺钉	Screw 1/4x40 L=8	2	
16	GC167	竖轴上伞齿轮组件	Pinion asm.	1	
17	GS033	伞齿轮螺钉	Screw 1/4x40 L=8	2	
18		下齿轮组件	Gear&pinion asm., lower	1	
19	GC166	竖轴下齿轮组件	Gear asm.	1	
20	GS033	伞齿轮螺钉	Screw 1/4x40 L=8	2	
21	GC165	下轴伞齿轮组件	Pinion asm.	1	
22	GS033	伞齿轮螺钉	Screw 1/4x40 L=8	2	
23	GZ435	竖轴	Upright shaft	1	
24	GN161	旋梭	Hook asm.	1	
25	GO472	竖轴上轴套	Upright shaft bushing, upper	1	
26	GO471	竖轴下轴套	Upright shaft bushing, lower	1	
27	GO470	下轴后轴套	Bushing rear	1	
28	GS053	竖轴上套紧固螺钉	Screw 3/16x28 L=7	1	
29	GR1519-8	下轴挡圈组件	Thrust collar asm.	1	
30	GS082-8	下轴挡圈螺钉	Screw 11/64x40 L=5	2	
31	GZ434-8	下轴	Lower shaft	1	
32	GR3371	旋梭定位钩	Bobbin case holder	1	
33	GS030-8	旋梭定位钩螺钉	Screw 11/64x40 L=9.5	1	
34	GS0559	下轴前轴套螺钉	Screw 3/16x28 L=7	1	
35	GO1002	下轴前轴套	Lower shaft front metal	1	
36		下轴限油组件	Oil seal screw asm.	1	
37	GR1515	下轴限油芯	Oil wick	1	
38	GS031	下轴限油螺钉	Oil seal screw	1	
39	GN163	梭心	Bobbin	1	
40	GN162	梭壳	Bobbin case	1	
41	GN161	旋梭梭壳组件	Hook bobbin case asm.	1	
42	GO053	下轴后轴套螺钉	Screw 3/16x28 L=13	1	
43	GR0341	针杆连接柱滑块座	Slide block base	1	
44	GR3372-7	下轴挡油圈组件	Lower shaft oil deflector asm	1	
45	GS210	挡油圈螺钉	Oil deflector screw 11/64 x 40 L=3.5	2	

5.压杆部件

HAND LIFTER COMPONENTS

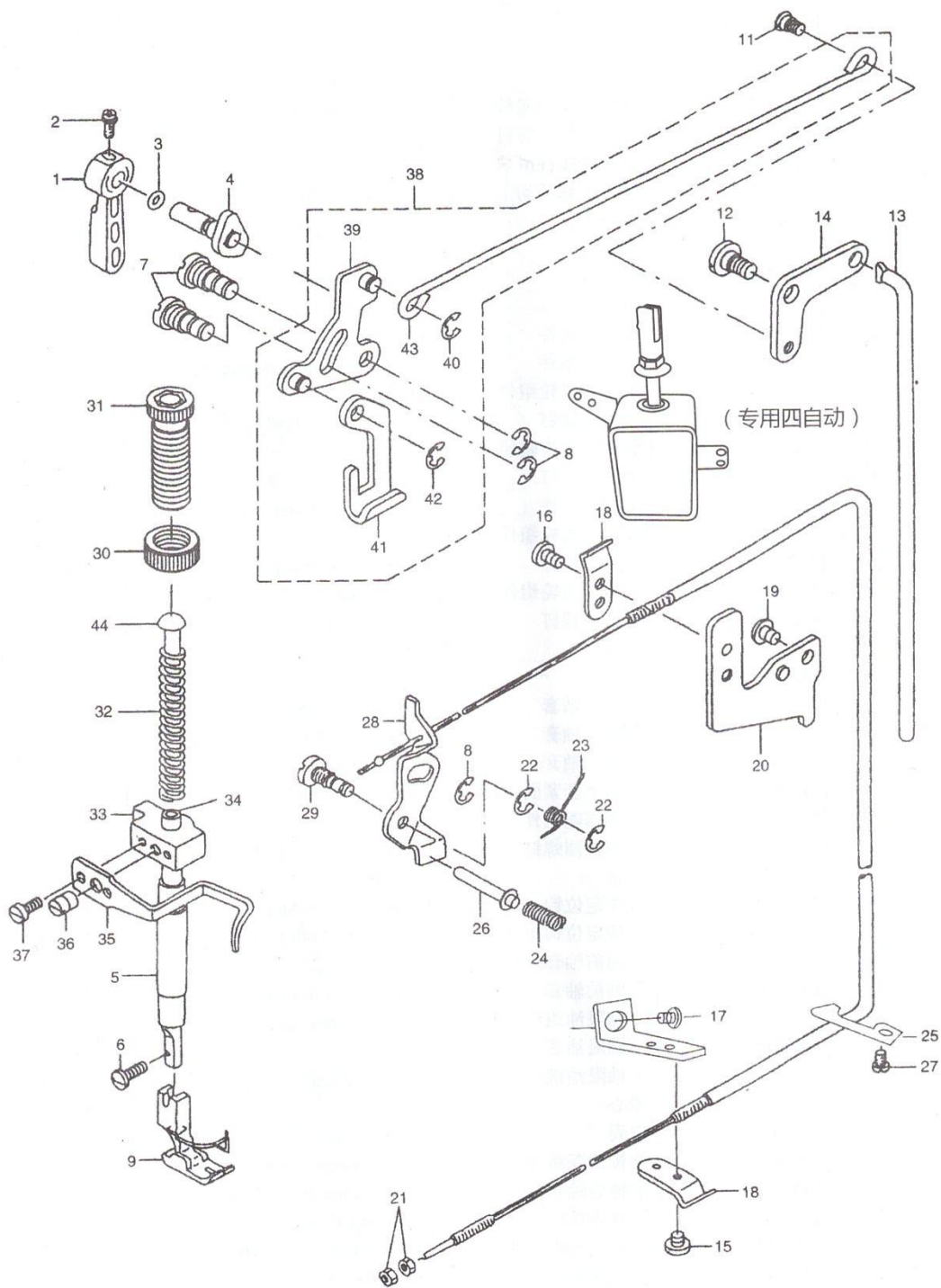

5.压杆部件

序号 Ref. NO.	件号 Part NO.	名称	Description	数量 Qty	备注 Note
1	GR3360	压脚扳手	Hand lifter	1	
2	GS0554	压脚扳手螺钉	Screw 9/64x40 L=10	1	
3	GR1503	压脚扳手轴O型圈	Rubber ring	1	
4	GR336/2	压脚扳手凸轮部件	Hand lifter cam asm.	1	
5	GO273	压杆轴套	Presser bar bushing lower	1	
6	GS020	活压脚螺钉	Screw 9/64x40 L=8	1	
7	GS0555	前杠杆螺纹销	Link shaft	2	
8	GR1510	螺纹销开口挡圈	E-ring 5	3	
9	GM200/5	活压脚部件	Presser foot asm.	1	
10		下压线底板	Wire holder bracket, lower	1	
11	GS0558	抬压脚拉杆螺钉	Hinge screw	1	
12	GS0557	后杠杆轴拉螺钉	Hinge screw	1	
13	GR3370	抬压脚顶杆	Knee lifter connecting rod	1	
14	GR3369	抬压脚后杠杆	Lifting lever link	1	
15	GS010	下压板紧固螺钉	Screw 11/64x40 L=5	1	
16	GS336-8	上压板紧固螺钉	Screw 11/64x40 L=5	1	
17		下压板组件紧固螺钉	Screw 15/64x28 L=14.5	1	
18	GR1017-8	拉线活压板	Wire holder	2	
19	GS310-8	上压板组件紧固螺钉	Screw 3/16x28 L=6	1	
20	GR1016-8	上压线底板	Wire holder bracket, upper	1	
21	GL6	拉线钮距调节螺母	Nut 3/16x32	2	
22	GR1510	螺纹销开口挡圈	E-ring 5	2	
23	GW433	松线顶板复位簧	Tension release return spring	1	
24	GW432	松线辅钉弹簧	Thread release pin spring	1	
25		软管右挡板	Wire cable holder	1	
26	GX568	松线辅钉	Tension release supporting pin	1	
27		右挡板紧固螺钉	Screw 3/16x28 L=6	1	
28	GR9890-50	松线顶板	Thread tension release wire	1	
29	GS0556	松线顶板螺纹销	Tension release shaft	1	
30	GL0114	调压螺母	Presser adjusting screw nut	1	
31	GS0553-8	调压螺钉	Presser spring regulator	1	
32	GW253	调压簧	Presser adjusting spring	1	
33	GR3358-8	压杆导架	Presser bar guide bracket	1	
34	GZ275	压杆	Presser bar	1	
35	GR9890-56	缓线调节钩	Presser bar thread guide	1	
36	GS033	压杆导架螺钉	Screw 1/4x40 L=8	1	
37	GS0100	缓线调节钩螺钉	Screw 9/64x40 L=8	2	
38		前杠杆组件	Knee lifting cross rod asm	1	
39	GR3364/3	抬压脚前杠杆部件	Hand lifter link	1	
40	GR1510	拉杆开口挡圈	E-ring 5	1	
41	GR3363	压脚升降板	Lifting lever	1	
42	GR3366	升降板连接开口挡圈	E-ring 5	1	
43	GR3368	抬压脚拉杆	Knee lifting cross rod	1	
44	GR1494	调压导杆	Presser guide bar	1	

6.送料部件

FEED MECHANISM COMPONENTS

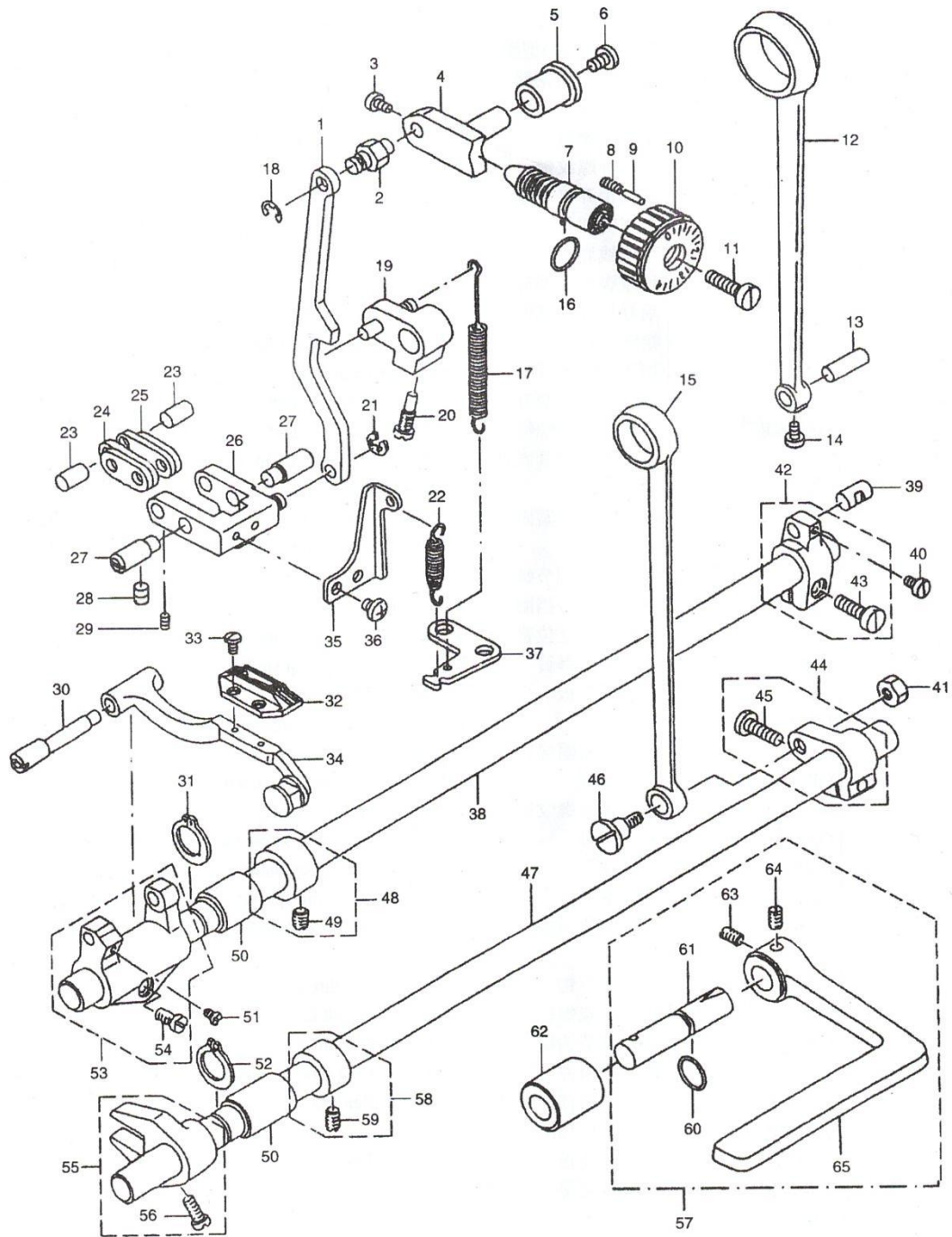

6.送料部件

序号 Ref. NO.	件号 Part NO.	名称	Description	数量 Qty	备注 Note
1	GH9890-24	倒送料连杆	Feed adjust rod	1	
2	GX9890-25	倒送料连杆销	Feed regulator pin	1	
3	GS011	连杆销螺钉	Screw 9/64x40 L=6	2	
4	GR3384	送料调节器	Feed regulator	1	
5	GO474	送料调节器轴套	Feed regulator bushing	1	
6	GSO565	送料调节器紧固螺钉	Screw 3/16x28 L=7	1	
7	GS9890-23	送料调节螺栓	Feed regulator screw	1	
8	GW257	送料距锁合簧	Spring	1	
9	GX576	送料距锁合销	Feed adjust pin	1	
10	GR3382-8	送料距旋钮	Feed dial	1	
11	GS0563	送料距旋钮螺钉	Screw 3/16x28 L=18	1	
12	GH568	送料连杆	Rocker shaft connecting rod	1	
13	GX570	送料连杆销	Walking foot long pin	1	
14	GSO560	送料连杆螺钉	Screw 9/64x40 L=4	1	
15	GH572	抬牙连杆	Connecting rod	1	
16	GR3383	送料调节螺栓O型圈	Rubber ring	1	
17	GW436	摆动板复位簧	Feed reverse spring	1	
18	GR1510	倒送料连杆销挡圈	E-ring 5	1	
19	GH547/2	倒送料曲柄组件	Feed reverse arm asm.	1	
20	GS2566	倒送料曲柄螺钉	Screw	1	
21	GR1510	倒送料连杆挡圈	E-ring 5	1	
22	GW435	倒送料拉簧	Spring	1	
23	GX571	短摆动板连接销	Walking foot short pin	2	
24	GR3374	送料长摆动板	Connecting link long pin	2	
25	GR3775	送料短摆动板	Connecting link short pin	2	
26	GR3376/2-8	送料摆动板座组件	Feed adjust link asm.	1	
27	GX573	送料摆动板座左右销	Adjusting link fulcrum shaft	2	
28	GS48	左右销螺钉	Screw 15/64x28 L=7	2	
29	GSO560	连杆销螺钉	Screw 9/64x40 L=4	2	
30	GX575	牙架销	Feed bar shaft	1	
31	GR1524	送料轴轴用挡圈	Retaining ring	1	
32	GM201	送料牙	Feed dog I	1	
33	GS072	送料牙螺钉	Screw 1/8x44 L=6	2	
34	GR3380/5-8	牙架部件	Feed bar asm.	1	
35	GR3388	摆动板复位板	Adjusting link spring guide	1	
36	GS0567	复位板紧固螺钉	Screw 11/64x40 L=5	2	
37	GR3387	拉簧固定板	Feed spring hood	1	
38	GZ436	送料轴	Feed rocker shaft	1	
39	GX571	送料曲柄销	Walking foot middle pin	1	
40	GS0560	曲柄销螺钉	Screw 9/64x40 L=6	1	
41	GL7	抬牙连杆轴位螺母	Nut 9/32x28	1	
42	GH569	送料曲柄组件	Feed rocker shaft crank asm.	1	
43	GS0561	送料曲柄螺钉	Screw 3/16x28 L=15.5	1	
44	GH571	抬牙后曲柄组件	Lifting rocker asm.	1	
45	GS0561	抬牙后曲柄螺钉	Screw 3/16x28 L=14	1	
46	GS0562	抬牙连杆轴位螺钉	Hinge screw	1	

6.送料部件

FEED MECHANISM COMPONENTS

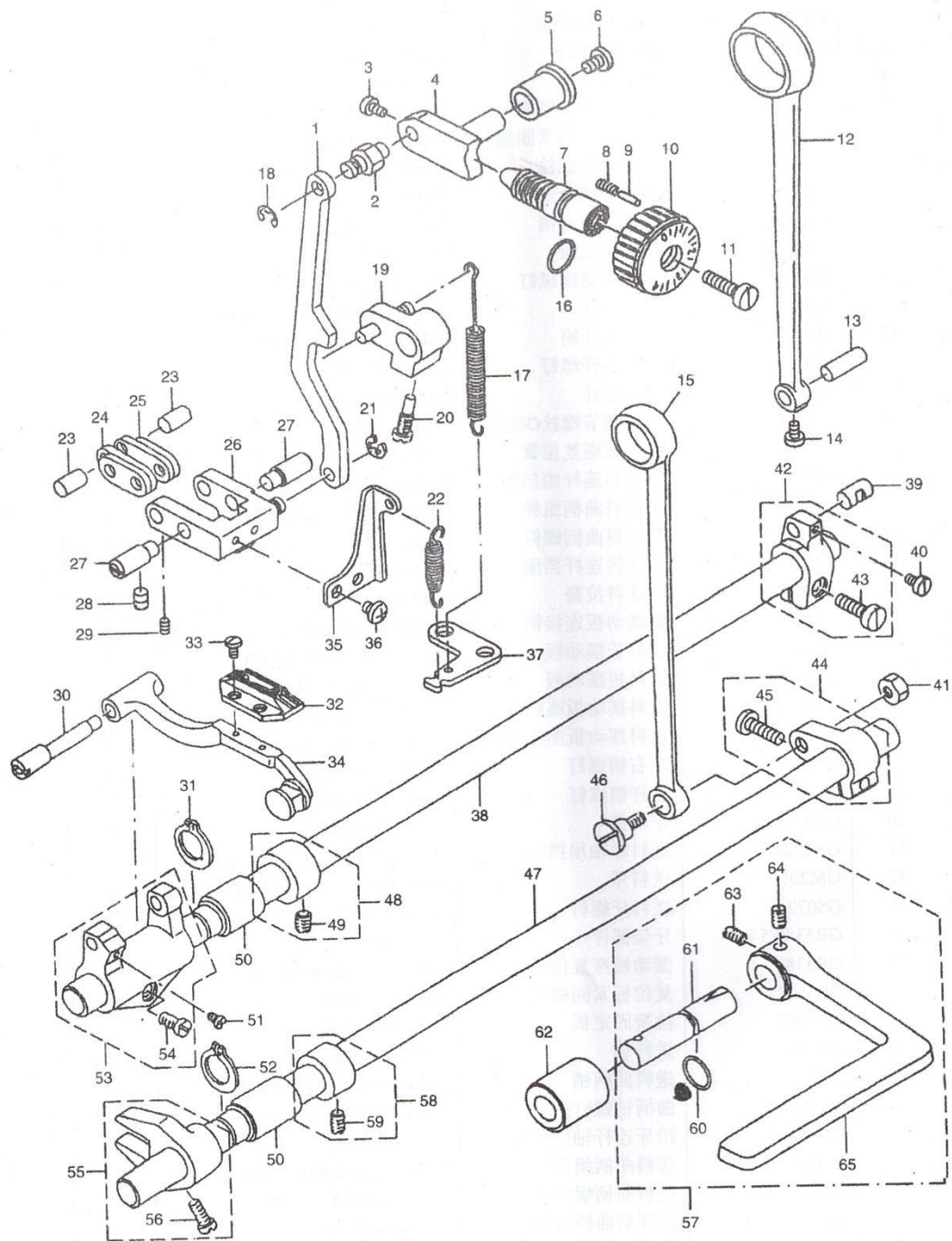

6.送料部件

序号 Ref. NO.	件号 Part NO.	名称	Description	数量 Qty	备注 Note
47	GZ437	拾牙轴	Feed driving shaft	1	
48	GR1469	拾牙轴挡圈组件	Thrust collar asm.	1	
49	GS39	送料轴挡圈螺钉	Screw 1/4x40 L=6	1	
50	GO473	送料轴前轴套	Feed rocker shaft bushing	2	
51	GS092	牙架销螺钉	Screw 11/64x40 L=7	2	
52	GR1524	拾牙轴轴用挡圈	Retaining ring	1	
53	GR3379-8	牙架座组件	Feed bar crank asm.	1	
54	GS69	牙架座螺钉	Screw 3/16x28 L=14	1	
55	GH570	拾牙叉曲柄组件	Driving shaft crank asm.	1	
56	GS037	拾牙叉曲柄螺钉	Screw 11/64x40 L=10.5	1	
57	GR3386-8	倒送料扳手组件	Reverse feed control lever asm.	1	
58	GR1469	拾牙轴挡圈	Thrust collar asm.	1	
59	GS39	拾牙轴挡圈螺钉	Screw 1/4x40 L=6	2	
60	GR3385	倒送料轴O型圈	Rubber ring	1	
61	GZ438	倒送料轴	Feed reverse shaft	1	
62	GO9890-57	倒送料轴轴套	Feed lever metal	1	
63	GS033	倒送料扳手螺钉	Screw 1/4x40 L=8.5	1	
64	GS050	倒送料扳手定位螺钉	Screw 1/4x40 L=10	1	
65	GR9890-64	倒送料扳手	Reverse feed control lever	1	

7.自动切线部件

THREAD TRIMMER COMPONENTS

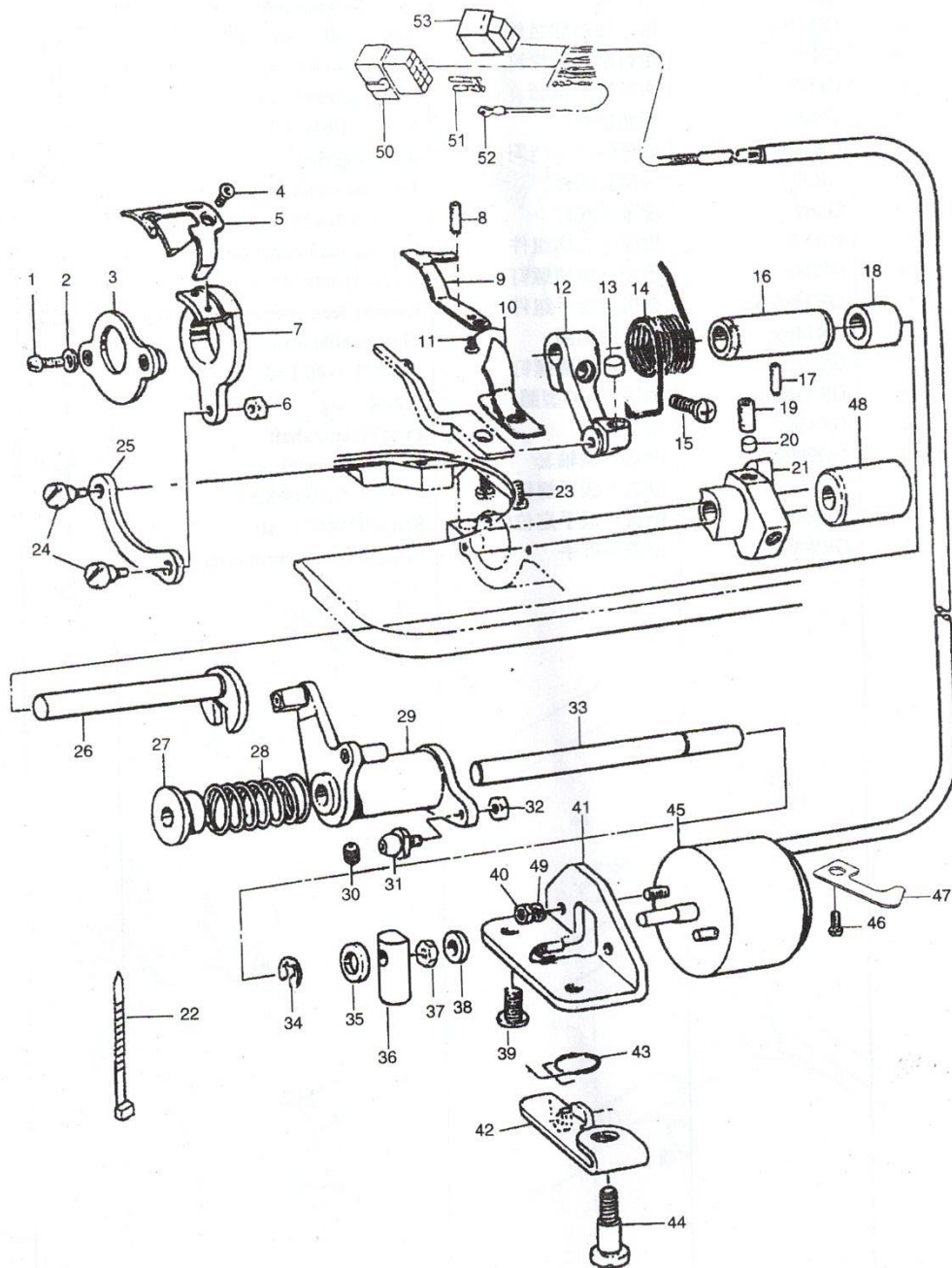

7.自动切线部件

序号 Ref. NO.	件号 Part NO.	名称	Description	数量 Qty	备注 Note
1	GS832	螺钉SM11/64"x40 L=12	Screw SM11/64x40 L=12	2	
2	GR7662	牙架座螺钉垫圈	Washer	2	
3	GR7661	刀架压板组件	Partiality shank asm.	1	
4	GS175	活动刀固定螺钉	Screw	2	
5	GR7663	活动刀	Moterial knife	1	
6	GL650	螺母 SM11/64"x40	Nut SM11/64x40	1	
7	GR7660	剪线刀架	Knife bracket	1	
8	GS9890-27	定刀调节螺钉	Screw	1	
9	GR7656	割线刀	Secant knife	1	
10	GR7658	护针片	Protect needle patch	1	
11	GS1755	螺钉 SM9/64"x40 L=4	Screw SM9/64x40 L=4	1	
12	GH1001	曲柄	Thread shear rock arm	1	
13	GR7664	驱动曲柄止动块	Positioning block	1	
14	GW951	弹簧	Spring	1	
15	GS1760	螺钉 SM3/16"x32 L=14	Screw SM3/16x32 L=14	2	
16	GO1001	切线轴套	Thread shear cam rock arm assy	1	
17	GS1761	螺钉 SM11/64"x40	Screw SM11/64x40	1	
18	GO1000	驱动曲柄轴衬套	Short bush	1	
19	GS1754	螺钉 SM1/4"x40 L=10	Screw SM1/4x40 L=10	1	
20		凸轮顶柱	Pole	2	
21	GR7656	凸轮	Thread shear cam	1	
22		尼龙扎带	Bale band	1	
23	GS788	螺钉 SM9/64"x40 L=5	Screw SM9/64x40 L=5	1	
24	GS1759	连杆螺钉 SM11/64"x40 L=5.5	Screw SM11/64x40 L=5.5	2	
25	GH1000	连杆	Knife shaft connecting rod	1	
26	GZ850	切线凸轮曲柄轴	Thread shear rock arm shaft	1	
27	GR7667	扭簧端盖	Spring cover	1	
28	GW952	弹簧	Spring	1	
29	GR7665	剪线驱动组件	Thread shear rock arm shaft	1	
30	GS189	螺钉 SM11/64"x40	Screw SM11/64x40	1	
31	G7666	滚柱	Rool shaft assy	1	
32	GL650	螺母	Nut	1	
33	GZ851	轴	Thread shear shaft	1	
34	GR7669	挡圈	Retaining ring	1	
35	GR7668	电磁铁缓冲垫	Magnetic plug cushion mat	1	
36	GR7672	切线电磁铁顶销	Magnetic plug pin	1	
37	GL652	螺母 SM1/4"x40	Nut SM1/4x40	1	
38	GR7671	垫圈	Washer	1	
39	GS1763	油泵安装螺钉	Screw	1	
40	GKL201-8	螺母 M4	Nut M4	2	
41	GR7670	切线磁铁支架	Magnetic plug cushion mat	1	
42	GR7677	松线座	Thread loose seat	1	
43	GWS953	弹簧	Spring	1	
44	GS1764	螺钉 SM1/4"x28 L=13	Screw SM1/4x28 L=13	1	
45	GQ785	剪线电磁铁组件	Magnetic plug	1	
46	GR3400-7	螺钉 SM15/64"x28 L=14.5	Screw SM15/64x28 L=14.5	1	
47	GS525-8	旋梭供油管压板	Electrical plug breacker washer	1	
48	GO1003	下轴中套	Bushing,lower shaft	1	
49	GKR202	垫圈4.5x8x0.5	Washer 4.5x8x0.5	2	
50	GR8800-61	14孔接线器	14 holes thread connector	1	
51	GR9890-78	接线端子	Conncting terminal	1	
52	GR8800-60	地线接头	Groundwire terminel	1	
53	GR9890-70	LED灯接线器	LED light's wire connector	1	

8. 自动倒缝部件

AUTOMATIC REVERSE FEED COMPONENTS

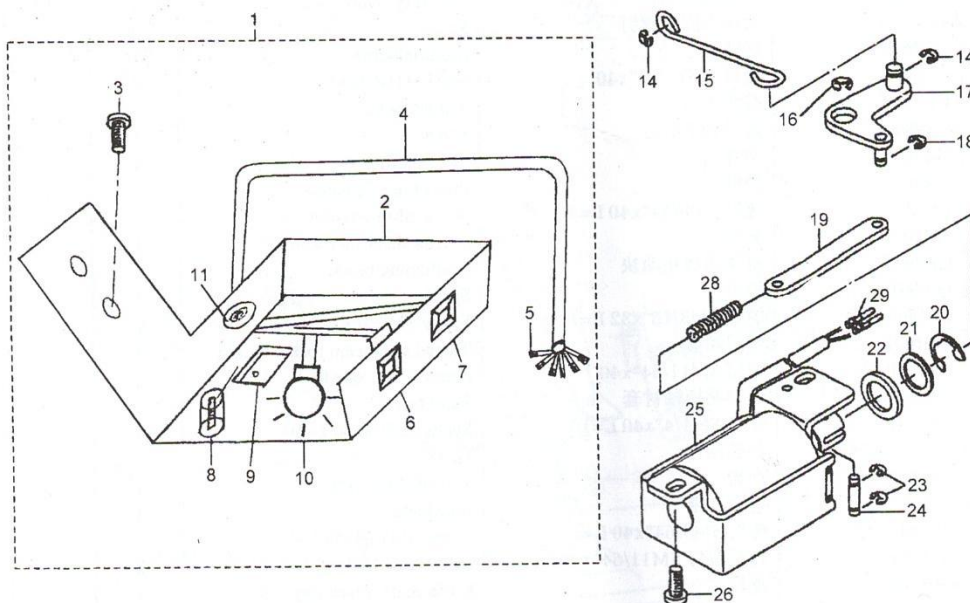

9. 夹线器

THREAD CLAMP DEVICE

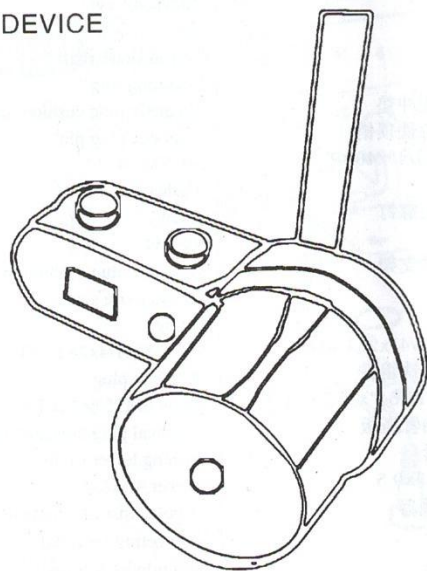

8. 自动倒缝部件

序号 Ref. NO.	件号 Part NO.	名称	Description	数量 Qty	备注 Note
1	GR9890-33	开关组件	Switch block	1	
2	GR9890-51	开关罩壳	Switck cover	[1]	
3	GS053	螺钉	Screw 3/16 x 28 L=9	[1]	
4	GR9890-33-1	电线	Wire	[1]	
5	GR9890-33-2	接线端子	Connecting terinal	[1]	
6	GR9890-33-3	倒缝按钮	Reverse feed button	[1]	
7	GR9890-33-4	LED灯按钮	LED light button	[1]	
8	GR9890-33-5	翻抬开关	Switch	[1]	
9	GR9890-33-6	电路板	Circuit board	[1]	
10	GR9890-33-7	LED灯	LED light	[1]	
11	GR9890-33-8	过线胶套	Thread guide cover	[1]	
12					
13					
14	GR625-8	开口挡圈	E-ring 5	2	
15	GR7687	自动倒送料拉杆	Reverse feed connecting shaft	1	
16		开口挡圈	E-ring 9	1	
17	GH1002	自动倒送料曲柄	Connecting arm asm.	1	
18	GR1028-8	开口挡圈	E-ring 4	1	
19	GR7691	自动倒送料连杆	Reverse feed connecting link	1	
20	GR1027-8	开口挡圈	E-ring 12	1	
21	GO363-8	垫片	Washer 16 x 24 x 2.6	1	
22	GO362-8	橡皮垫片	Rubber plunger	1	
23	GR1028-8	开口挡圈	E-ring 4	2	
24	GR7692	连杆销	Plunger arm pin	1	
25	GQ796	自动倒送料点磁铁	Reverse feed magnet asm.	1	
26	GS525-8	螺钉	Screw 15/64 x 28 L=12	2	
27		螺钉	Screw 3/16 L=9	1	
28		自动倒送料连杆顶簧	Plunger spring	1	
29		电线插针	Pin contact	2	
30		螺钉	Screw 3/16 x 28 L=6	1	

9. 夹线器

10. 润滑部件

OIL LUBRICATION COMPONENTS

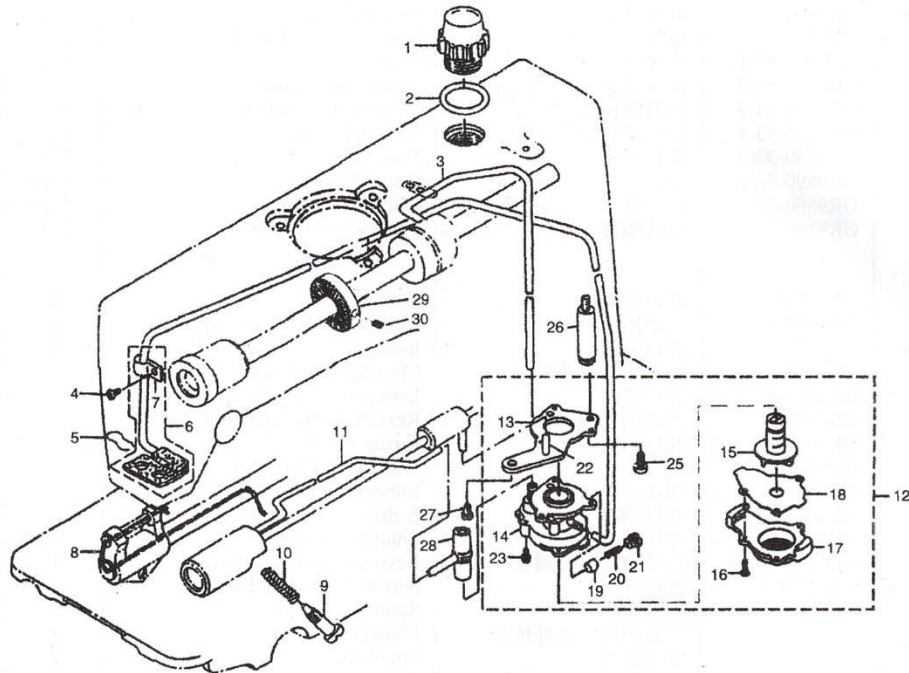

11. 油盘部件

OIL RESERVOIR COMPONENTS

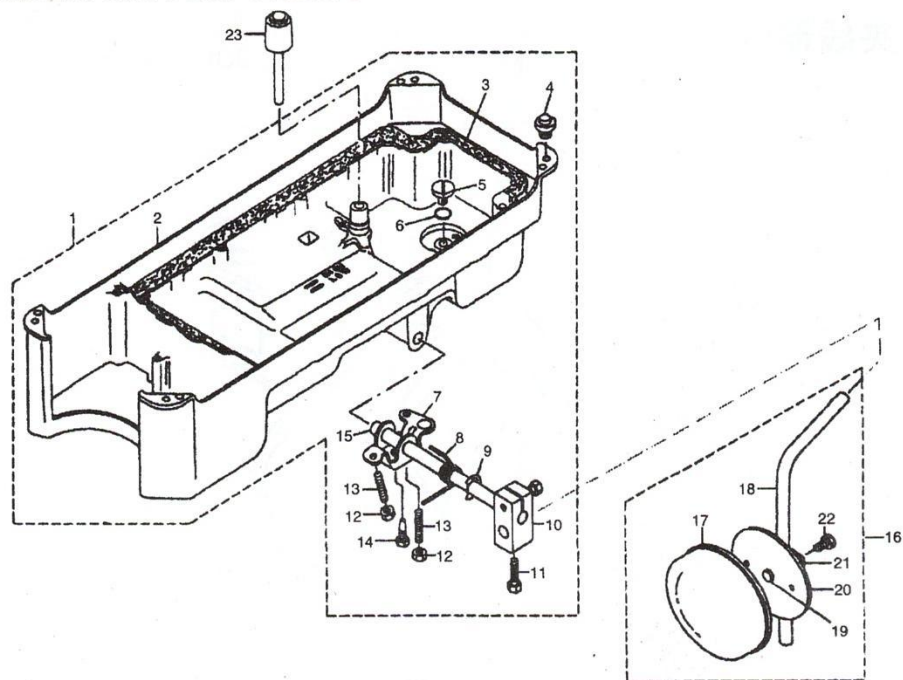

10. 润滑部件

序号 Ref. NO.	件号 Part NO.	名称	Description	数量 Qty	备注 Note
1	GR1561-8	油窗	Oil sight window	1	
2	GR1562	油窗O型圈	Rubber ring	1	
3	GR3398	上轴供油管	Main shaft oil tube	1	
4	GR0551	回油管夹螺钉	Screw 3/16x28 L=6	1	
5	GR1569	回油毡夹	Oil felt presser	1	
6	GR3401	回油管组件	Oil return tube asm	1	
7	GR1566	回油管夹	Holder	1	
8	GR3378	送料轴油线	Oil wick	1	
9	GS054-8	旋梭油量调节螺钉	Oil adjusting screw	1	
10	GW259-8	旋梭油量调节簧	Spring	1	
11	GR3399-8	旋梭供油管	Oil tube	1	
12	GR3389/12	油泵部件	Lubricating oil pump asm	1	
13	GR3390	油泵安装板	Oil pump installing base	1	
14	GR3391	油泵体	Oil pump	1	
15	GR3392	油泵叶轮	Oil pump impeller	1	
16	GS554	油泵盖螺钉	Screw D=3 L=10	3	
17	GR3394	油泵盖	Lubricating oil pump cover	1	
18	GR3393	油泵叶轮托板	Oil pump impeller cover	1	
19	GR3396	回油柱塞	Plunger	1	
20	GW437	柱塞簧	Plunger spring	1	
21	GS0569	柱塞螺钉	Plunger screw	1	
22	GR3395	下轴供油管	Hook driving shaft oil tube	1	
23	GS0568	油泵安装螺钉	Screw M3 L=8	3	
24	GS030	螺柱连接螺钉	Screw 11/64x40 L=9.5	1	
25	GS0567-8	油泵连接螺柱	Oil pump support, large	1	
26	GS062	油泵螺钉	Screw 15/64x28 L=12	1	
27	GR3397	供油管接头	Rubber joint	1	
28	GS9890.39	绕线器驱动轮	Bobbin pulley	1	
29	GS1761	绕线器驱动轮螺钉	Screw	2	

11. 油盘部件

1	GR3405/17	油盘部件	Oil reservoir asm	1	
2	GR3406	油盘	Oil reservoir	1	
3	GR3407	油盘垫	Oil reservoir gasket	1	
4	GR3408	机头座垫	Rubber cushion	4	
5	GS0571	排油孔螺钉	Screw 5/16x24 L=7	1	
6	GR3409	排油孔螺钉O型圈	Rubber ring	1	
7	GH576	抬压脚双向曲柄	Knee lifting rotating arm	1	
8	GW438	双向曲柄扭簧	Spring	1	
9	GR1583	抬压脚轴开口挡圈	E-ring 10	1	
10	GR3410	抬压脚操纵杆节头	Vertical shaft fitting arm	1	
11	GS0573	操纵杆节头螺钉	Screw	2	
12	GL21	双向曲柄限位调节螺母	Nut M6	2	
13	GS057	双向曲柄限位调节螺钉	Screw M6 L=30	2	
14	GS0572	双向曲柄螺钉	Screw M6 L=17.5	1	
15	GZ439	抬压脚轴	Knee press cross shaft	1	
16	GR3411/6	操纵杆部件	Knee pan plate asm	1	
17	GKR13	操纵杆软垫	Knee pan plate cover	1	
18	GR1586	操纵杆	Knee pan upright shaft	1	
19	GR3413	操纵杆垫	Knee pan plate rubber	1	
20	GR3412	操纵板	Knee pan plate	1	
21	GR3414	操纵杆节头	Knee pan plate support	1	
22	GS584	节头螺钉	Screw M6 L=12	1	
23	GH579	抬压脚顶销	Knee lifter push rod	1	

12.过线架部件

THREAD STAND COMPONENTS

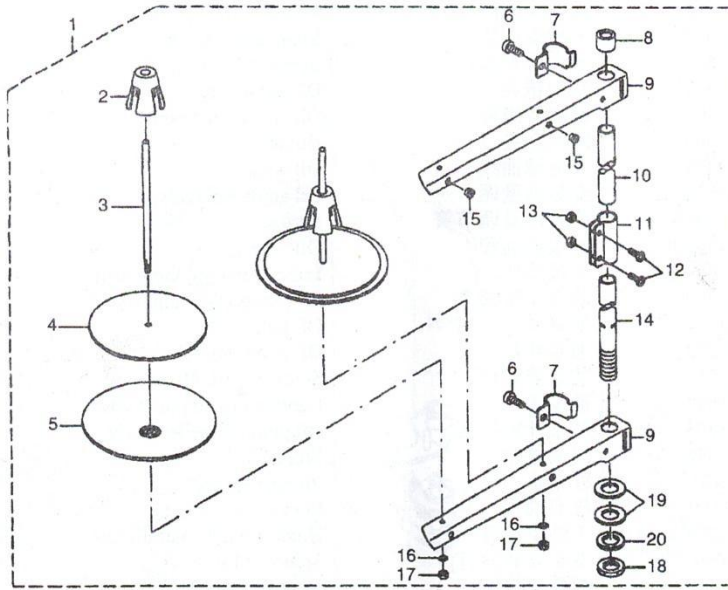

13.附件

ACCESSORIES

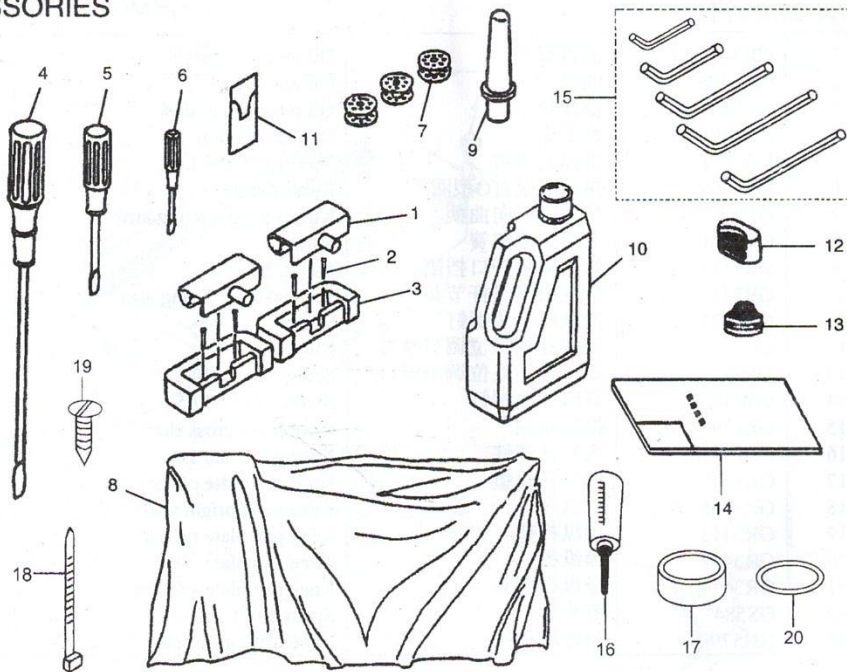

12. 过线架部件

序号 Ref. NO.	件号 Part NO.	名称	Description	数量 Qty	备注 Note
1		过线架部件	Thread stand asm.	1	
2	GR1215	线团防送垫	Spool retainer	2	
3	GS067	线盘钉	Spool pin	2	
4	GR750	线盘轮垫	Spool rest cushion	2	
5	GR1811	线盘	Spool rest	2	
6	GS558	线架过线夹螺钉	Screw M6 L=16	2	
7	GR1745	线架过线夹	Thread guide arm joint	2	
8	GR1744	线架杆顶防护橡皮	Spool rest rod rubber cap	1	
9	GR1825	线架过线杆	Spool rest arm	2	
10	GZ316-8	线架杆上节	Spool rest rod, upper	1	
11	GR1932	线架杆接头	Spool rest rod joint	1	
12	GS401	线架杆接头螺钉	Screw M5 L=14	2	
13	GL158	线架杆接头螺母	Nut M5	2	
14	GZ315-8	线架杆下节	Spool rest rod, lower	1	
15	GR1748	过线圈	Thread guide	2	
16	GR1625	线盘钉弹簧垫	Spring washer	2	
17	GL23	线盘钉螺母	Nut M5	2	
18	GL158	线架杆紧固螺母	Nut M16 x 1.5	1	
19	GR1696	线架杆紧固螺母垫圈	Washer 16 x 30 x 2.6	2	
20	GR1751	紧固螺母弹簧的垫圈	Spring washer	1	

13. 附件

序号 Ref. NO.	件号 Part NO.	名称	Description	数量 Qty	备注 Note
1	GR1590/2	机头连接钩组件	Machine hinge plate asm.	2	
2	GK241	机头连接钩座钉	Nail	4	
3	GBX105	机头连接钩座	Machine hinge plate	2	
4	GR1610	螺丝刀(大)	Screw driver, large	1	
5	GR1602	螺丝刀(中)	Screw driver, medium	1	
6	GR1603	螺丝刀(小)	Screw driver, small	1	
7	GN163-8	梭心	Bobbin	3	
8	GF424	机头罩	Macgube head cover	1	
9	GBR148	机头支柱	Macgube rest cover	1	
10	GR1604/3	油箱部件	Oil reservoir asm.	1	
11	GV15	机针	Needle DB x 1 #14-#16	1包	
12	GR1578-8	防震垫(A)	Quakeproof washer A	1	
13	GR1579-8	防震垫(B)	Quakeproof washer B	1	
14		说明书	Instruction book	1	
15		内六角扳手(1.5, 2, 2.5, 3, 4)	Cross screw driver (1.5, 2, 2.5, 3, 4)	各1	
16		小油壶	Oiler asm	1	
17	GR1576	油盘磁铁	Oil reservoir magnet	1	
18		尼龙扎带	Cable band	5	
19	GBR147	木螺钉	Wood screw	4	
20	GS0574	垫圈	Washer	4	